

# 9. Flow Chart of Troubleshooting

## 9-1. BASEBAND

### 9-1-1. Power On

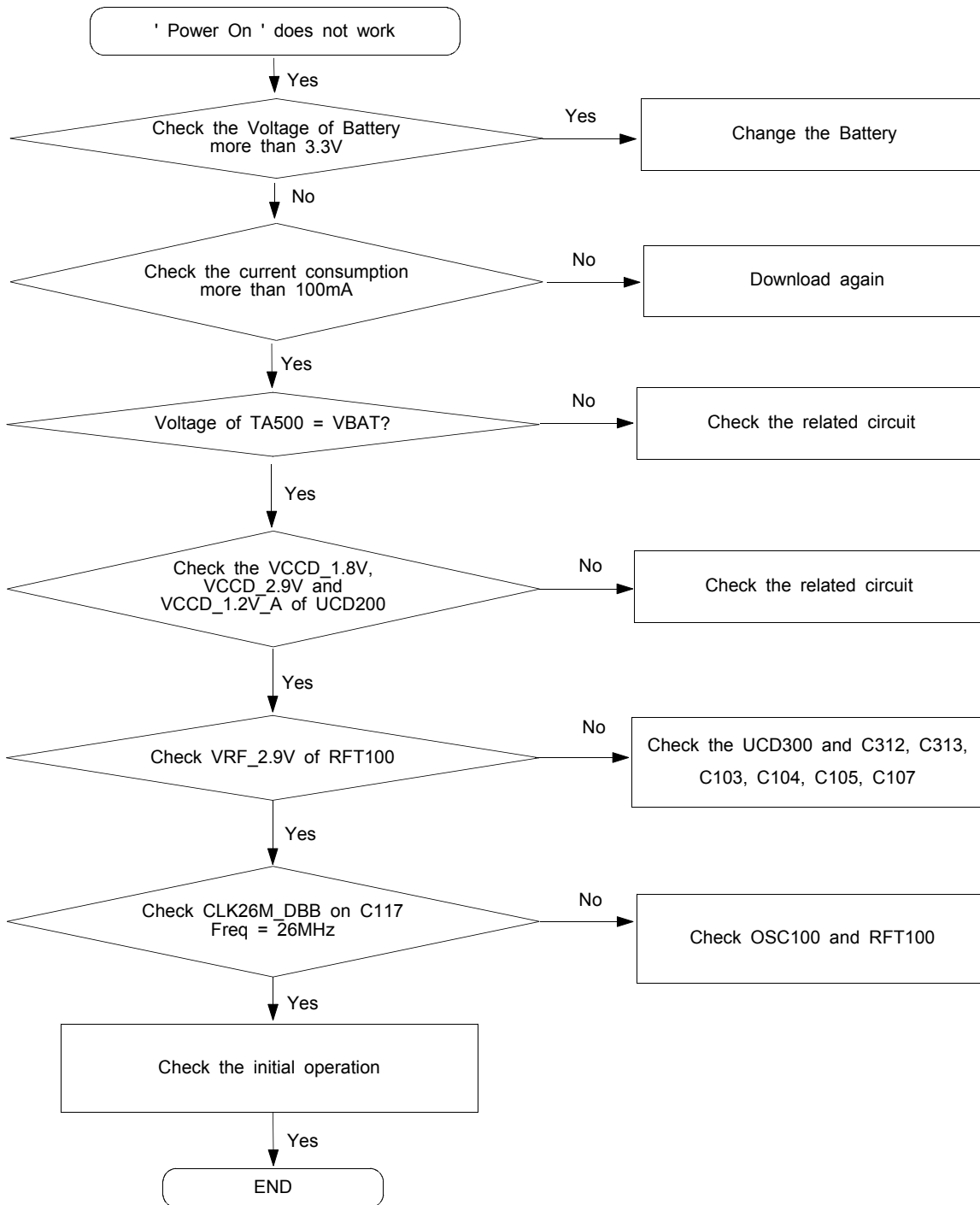

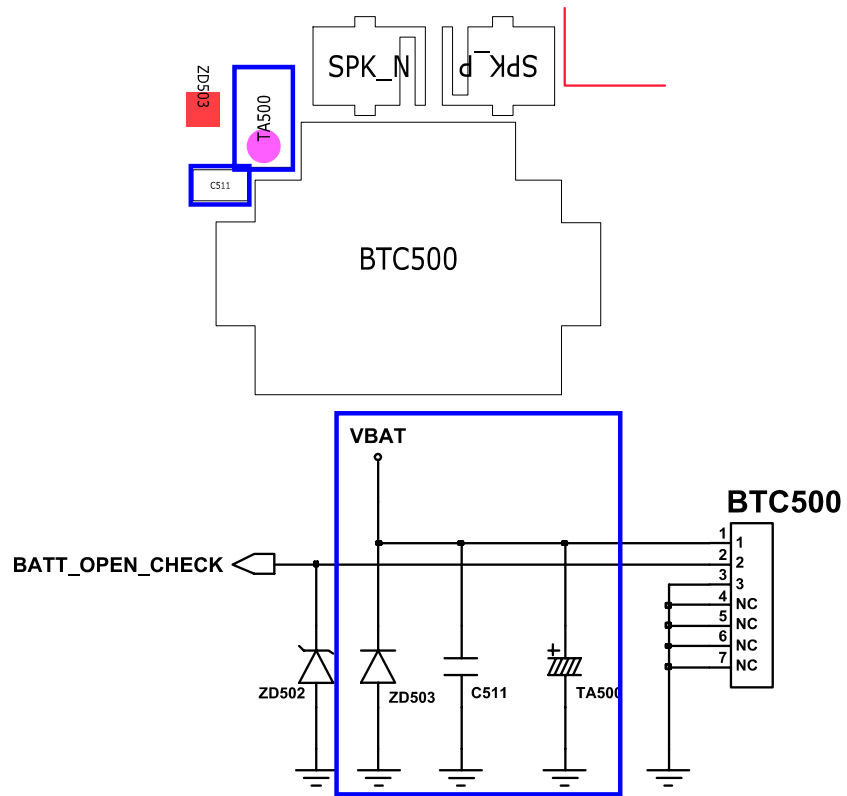



# Flow Chart of Troubleshooting

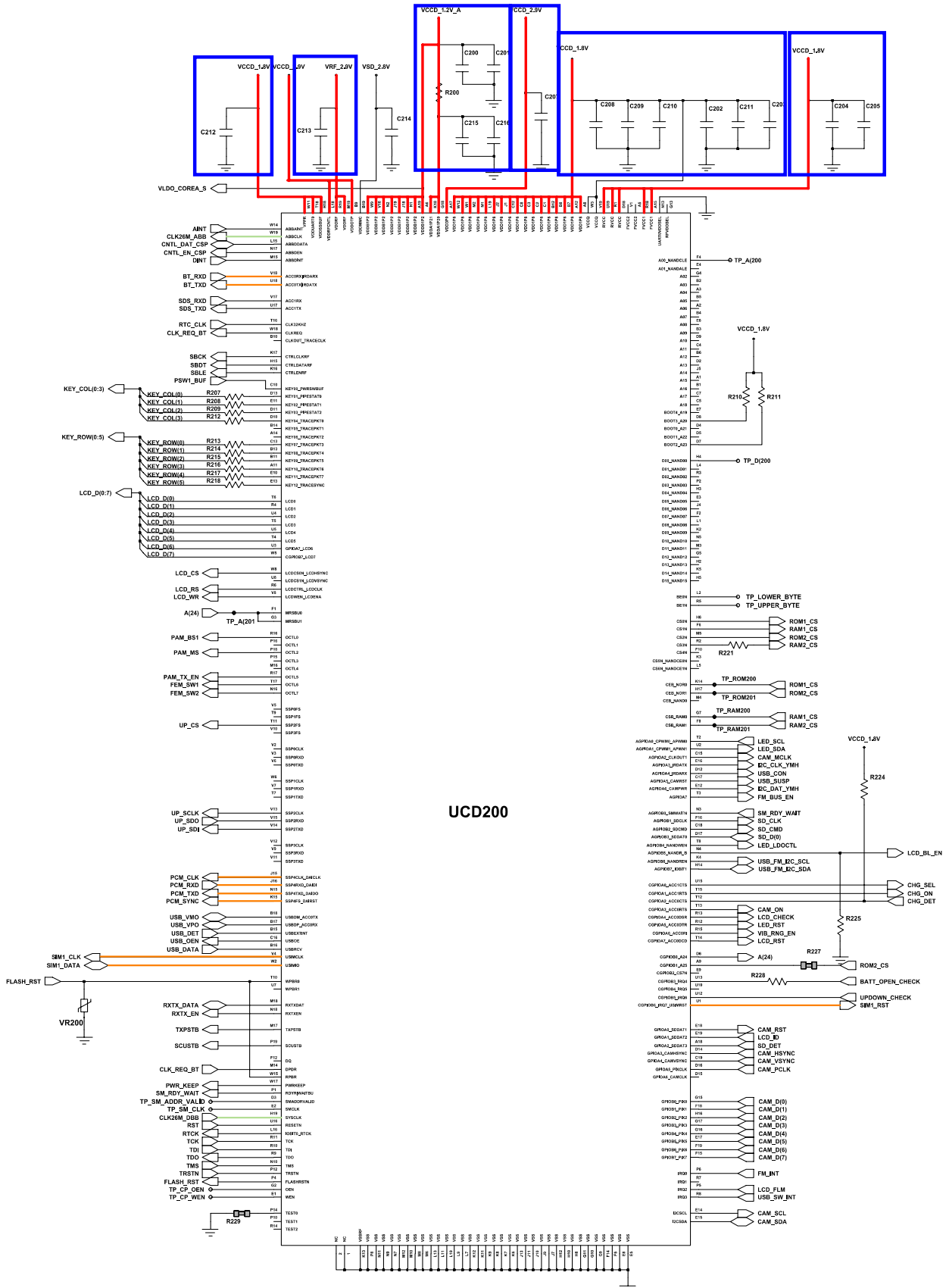

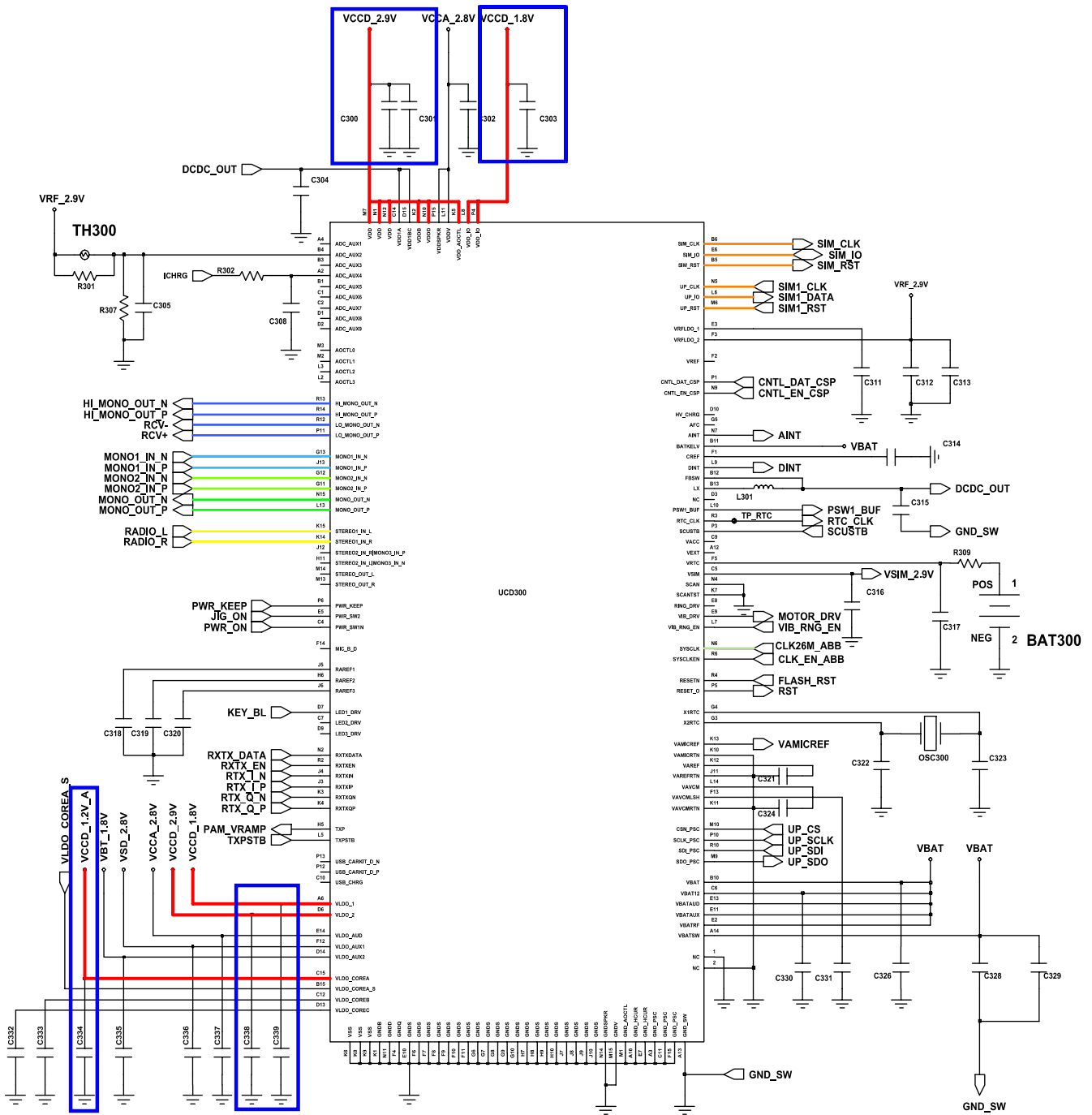

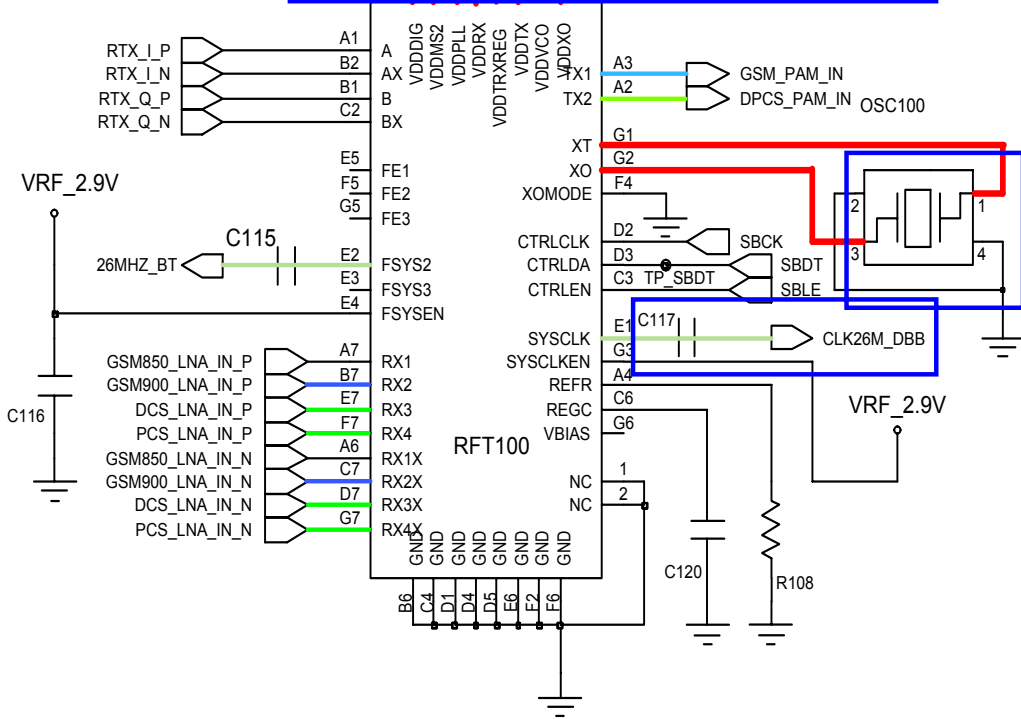
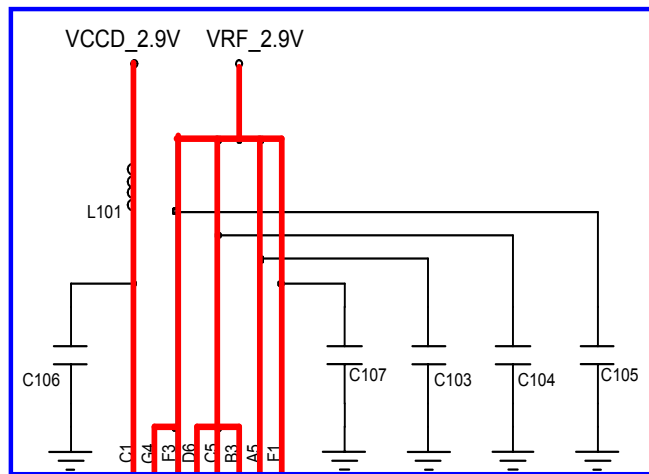
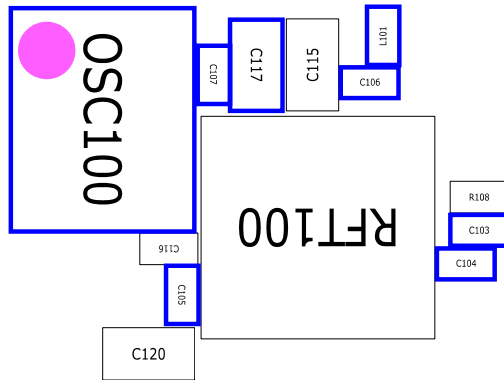

### 9-1-2. Initial

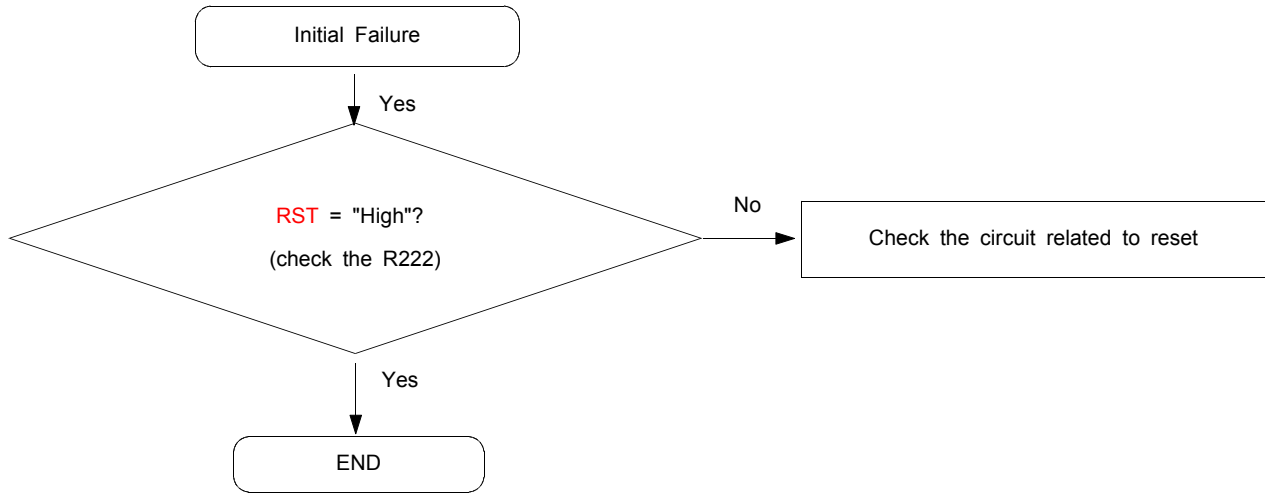

# Flow Chart of Troubleshooting

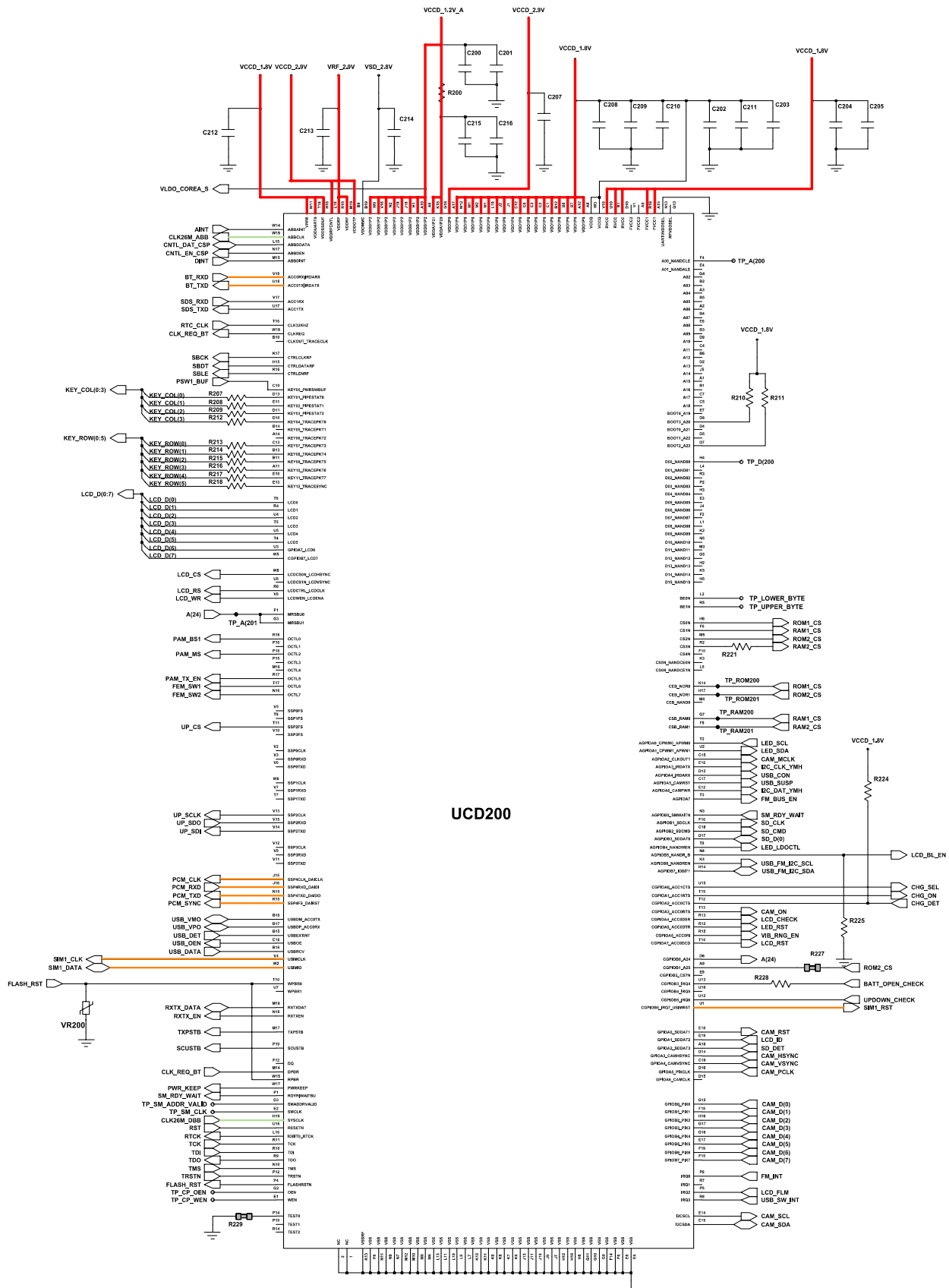



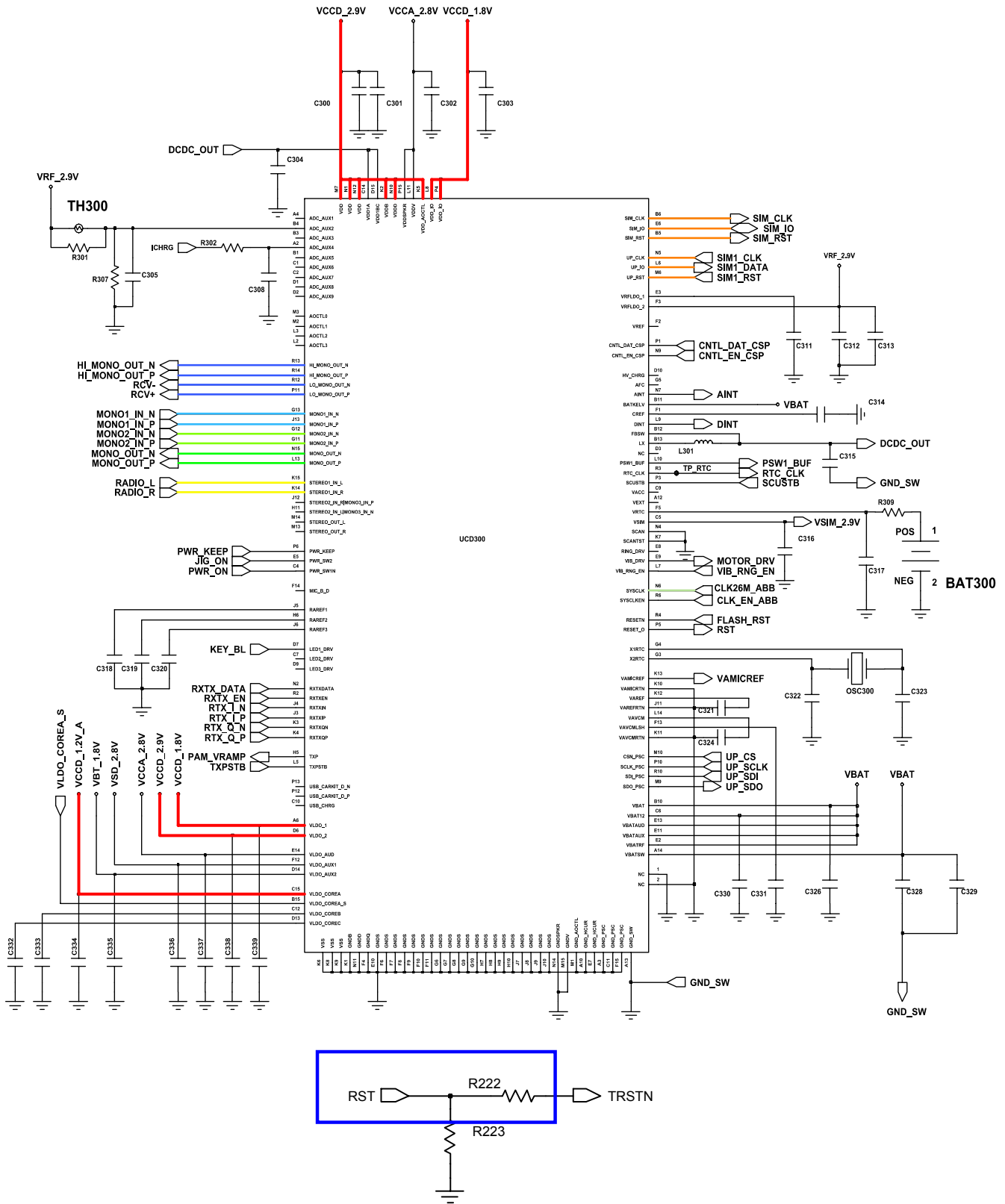

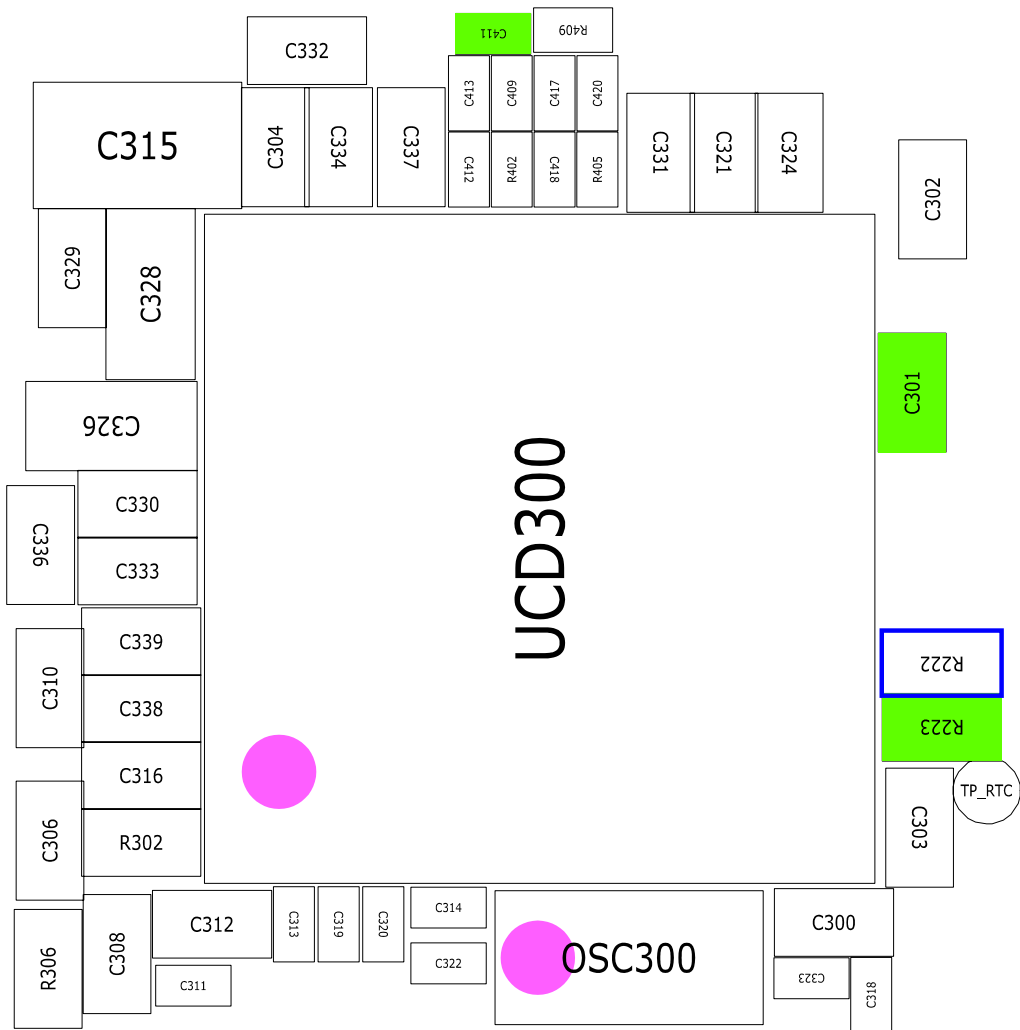

### 9-1-3. Charging Part

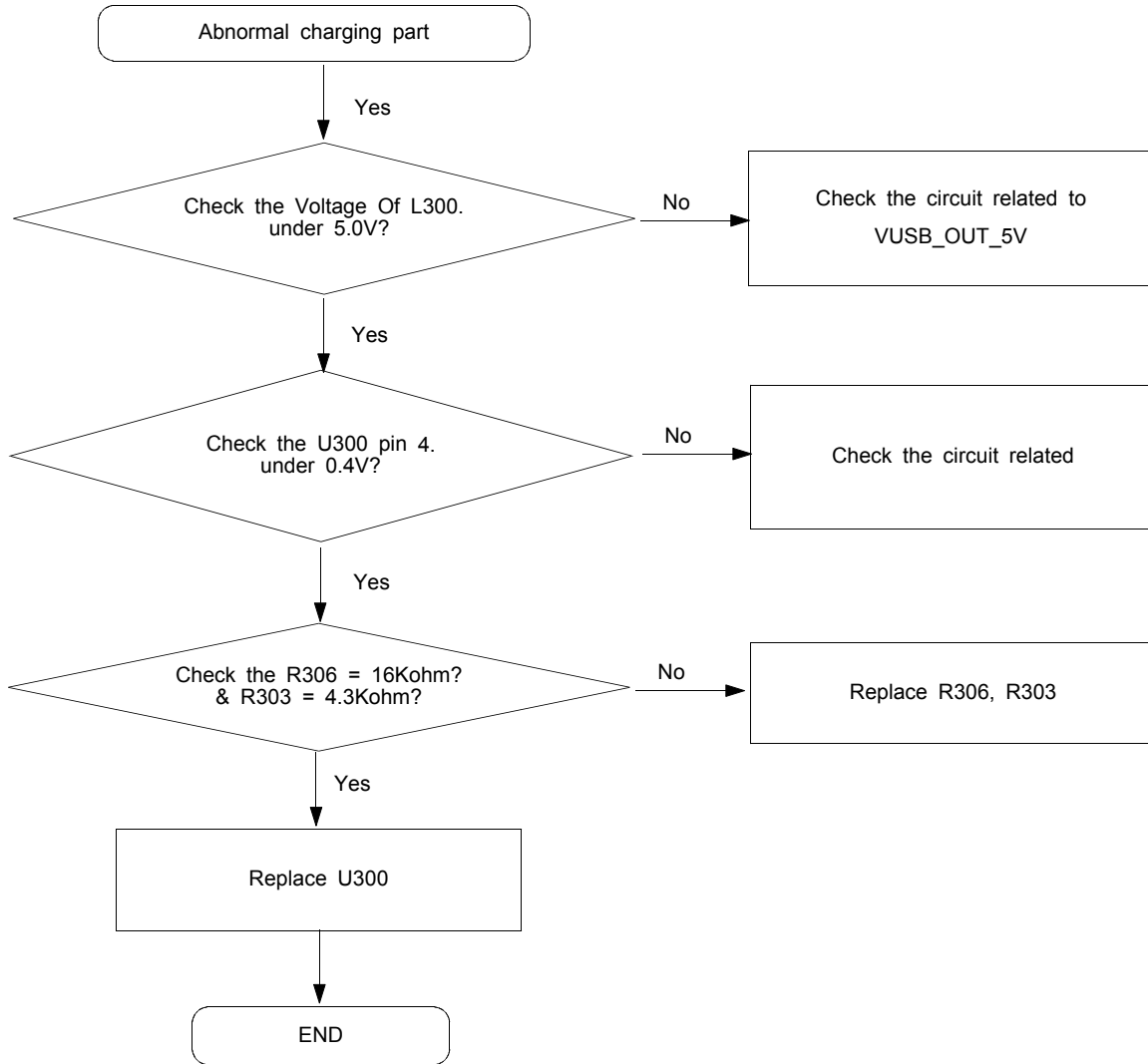

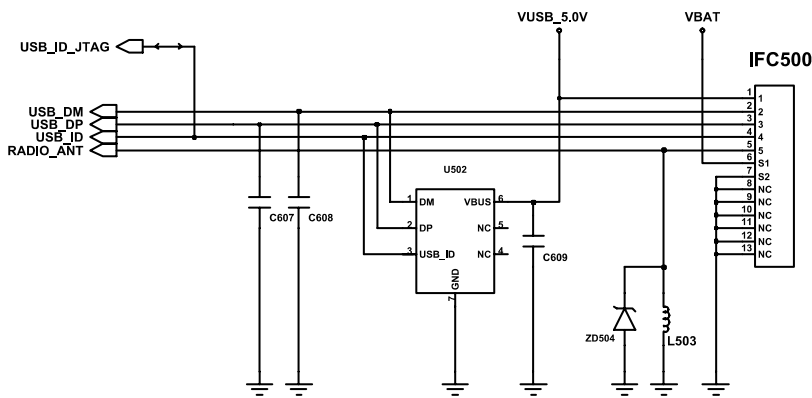
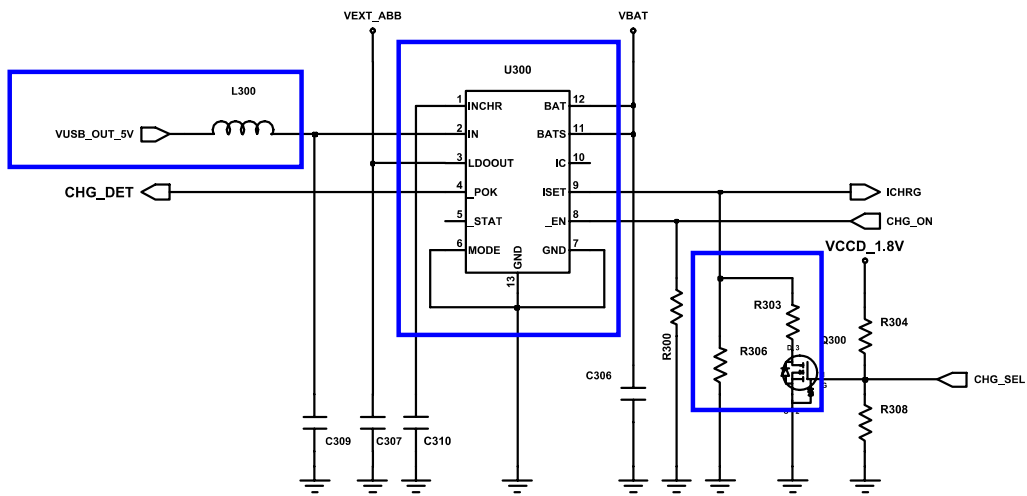
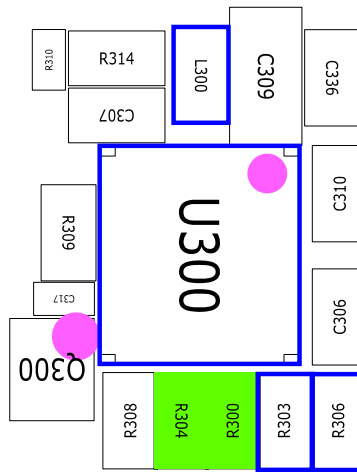

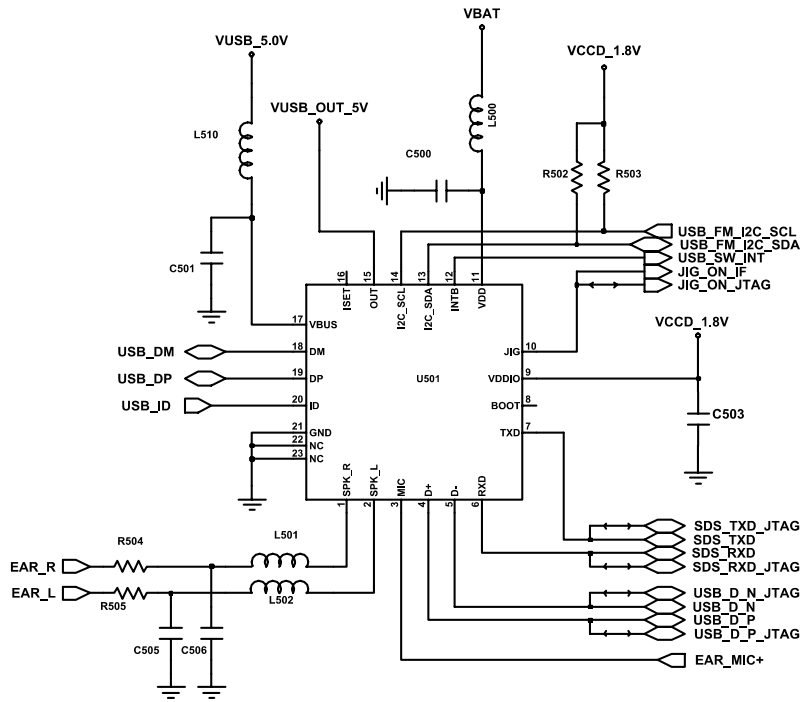

### 9-1-4. Sim Part

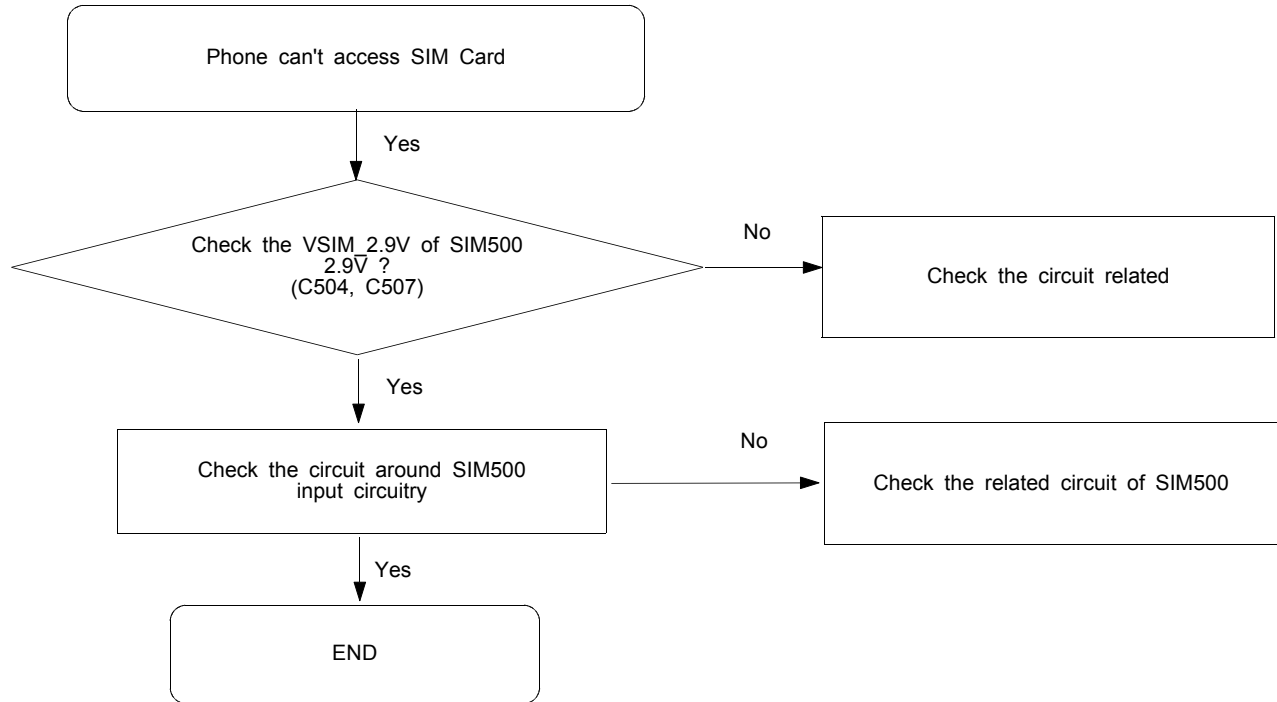

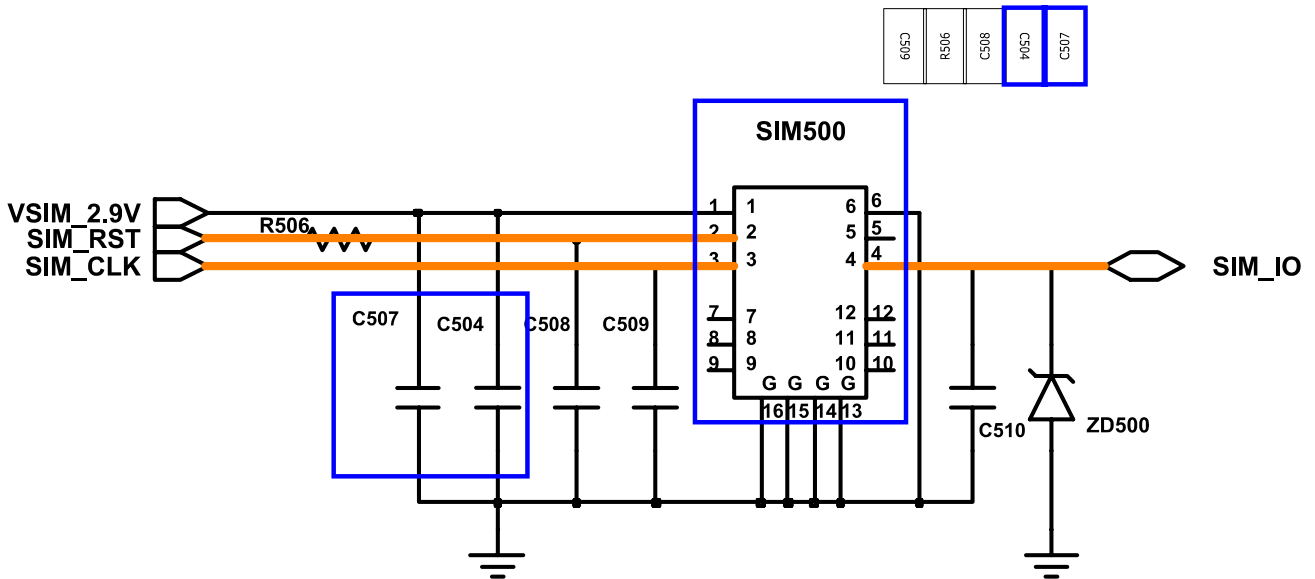
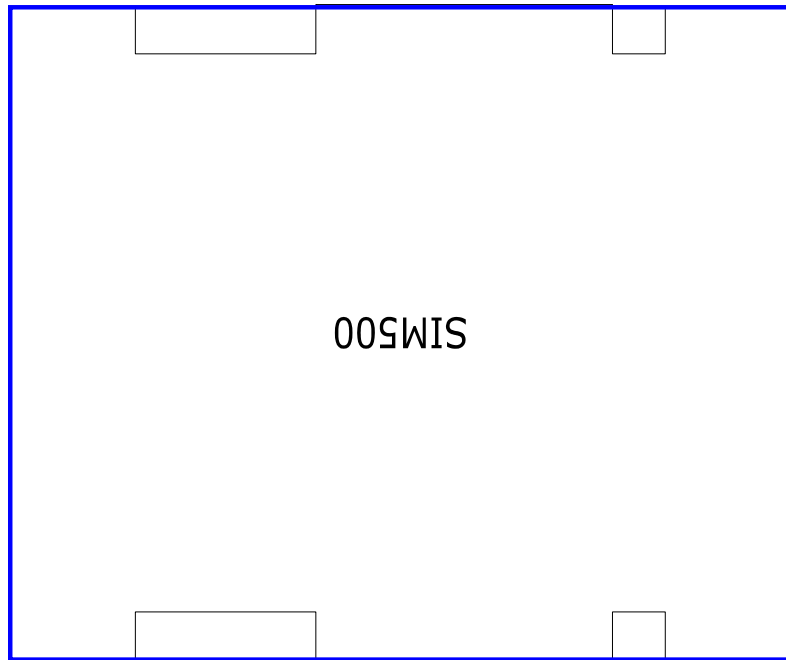

### 9-1-5. Microphone Part

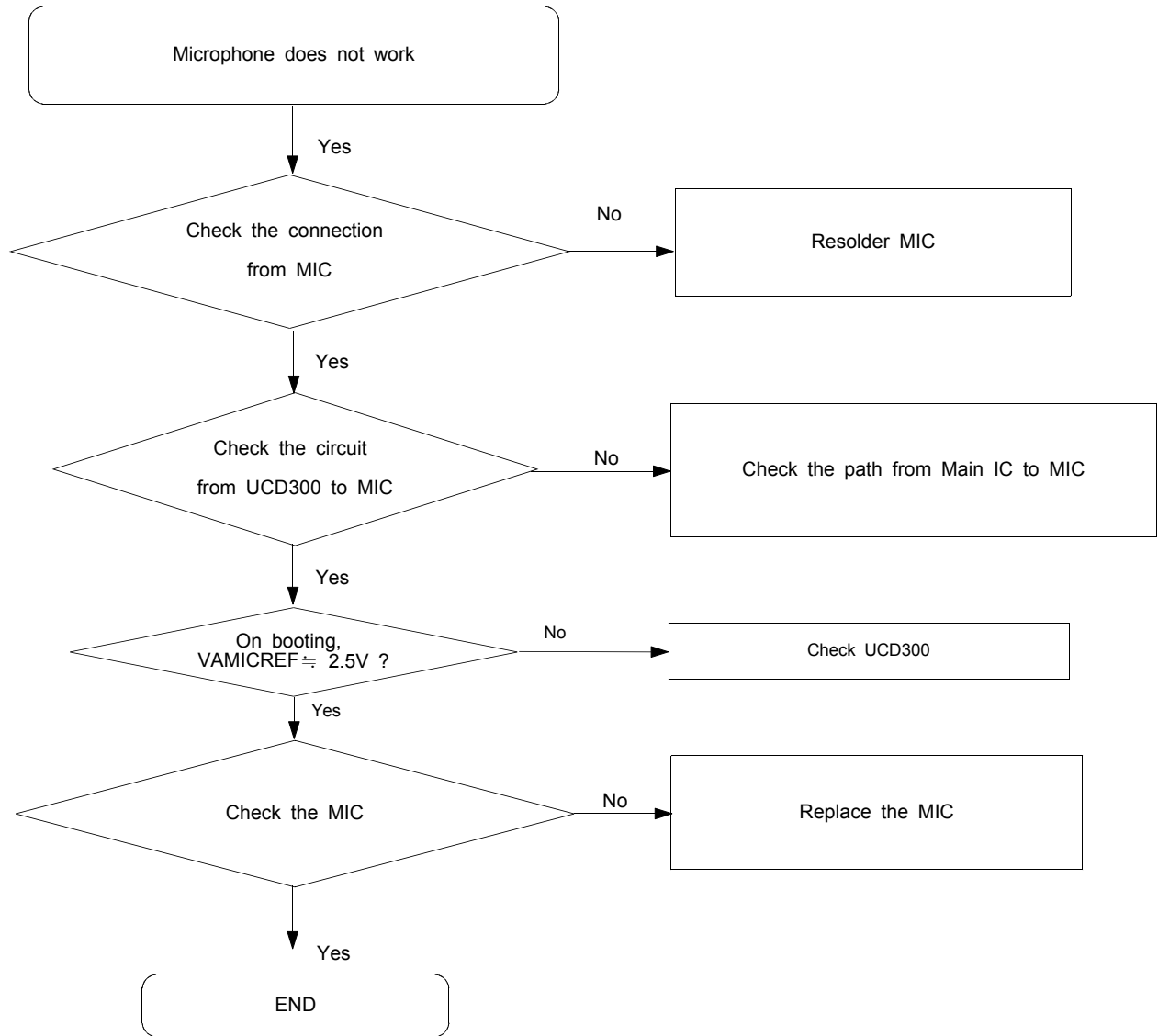



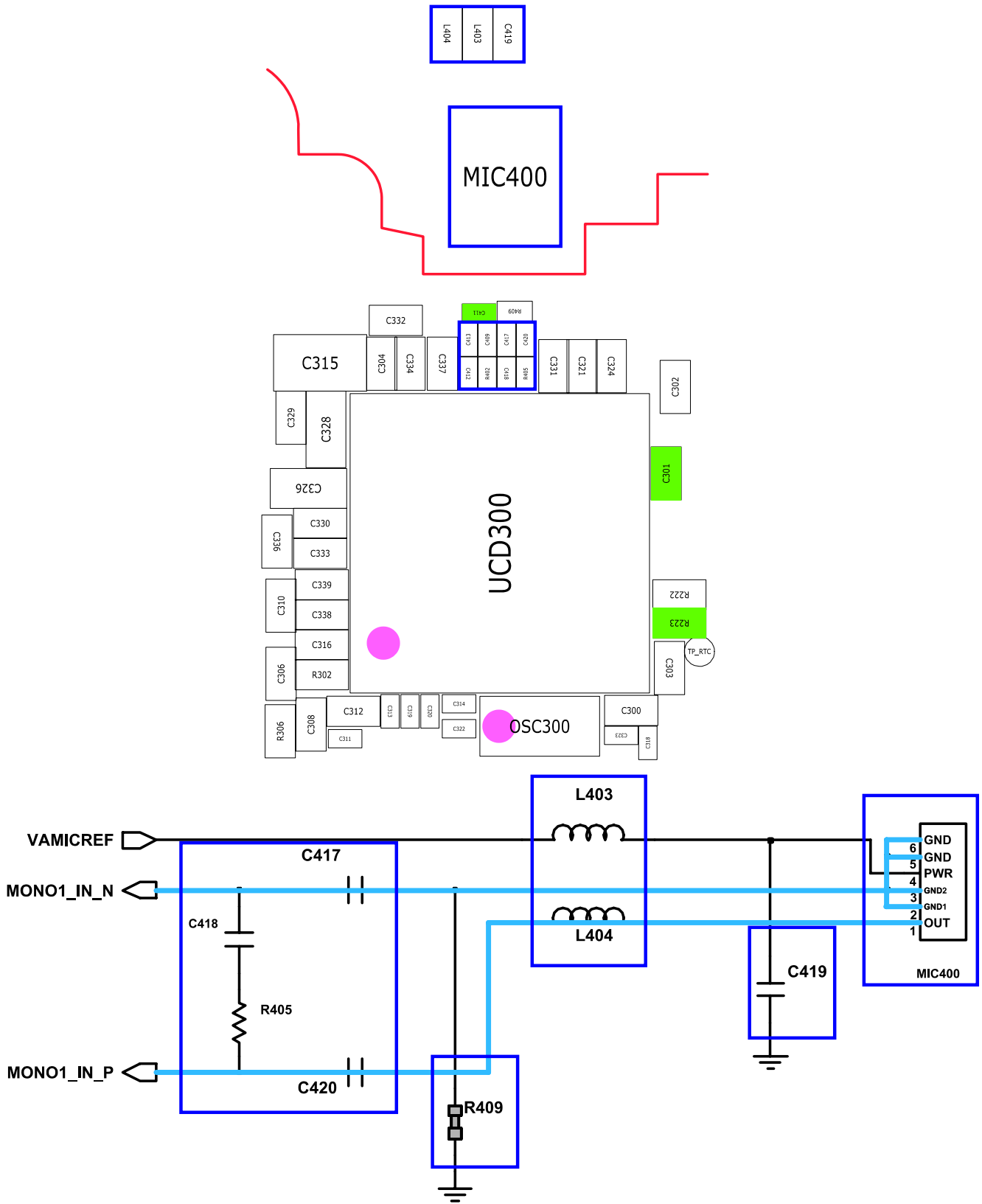

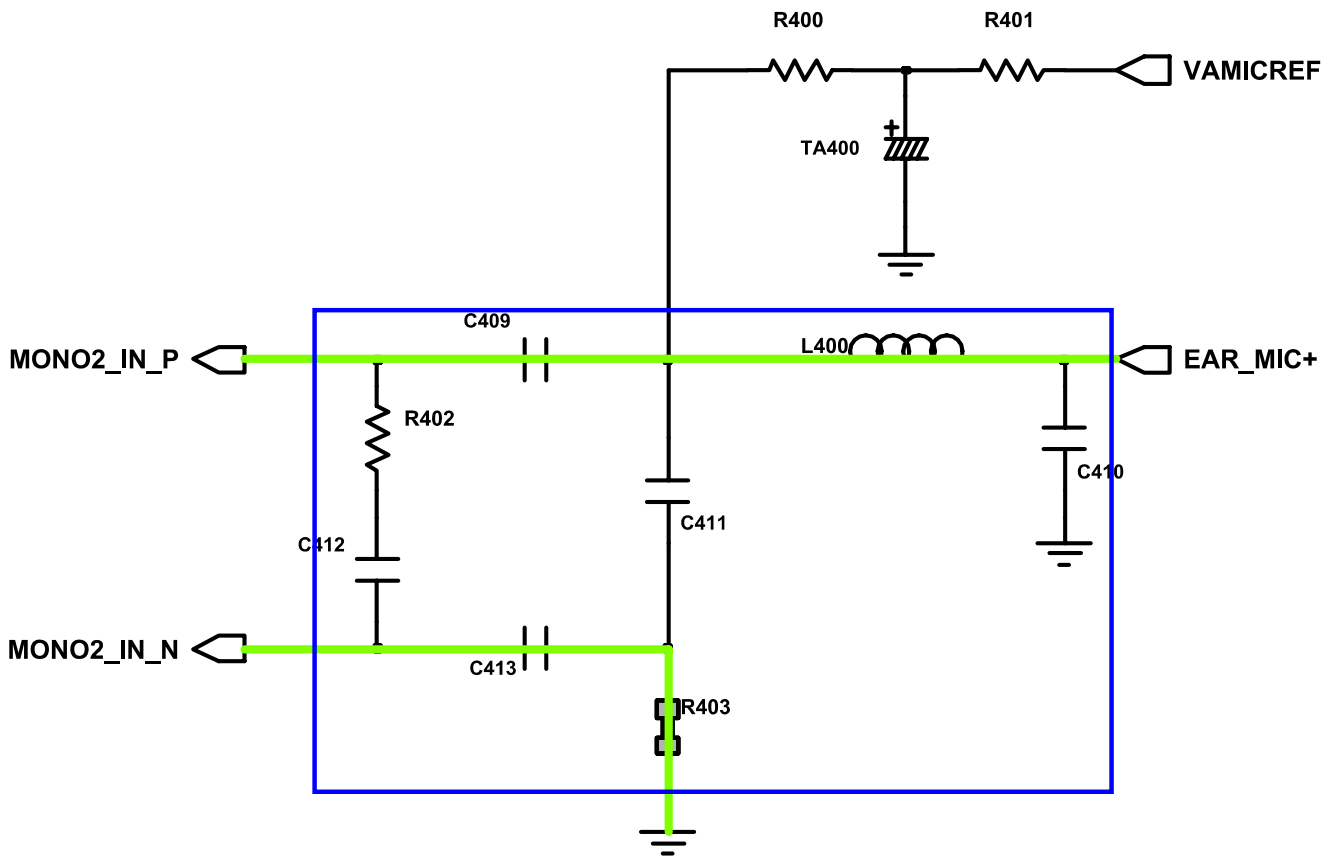

### 9-1-6. Receiver Part

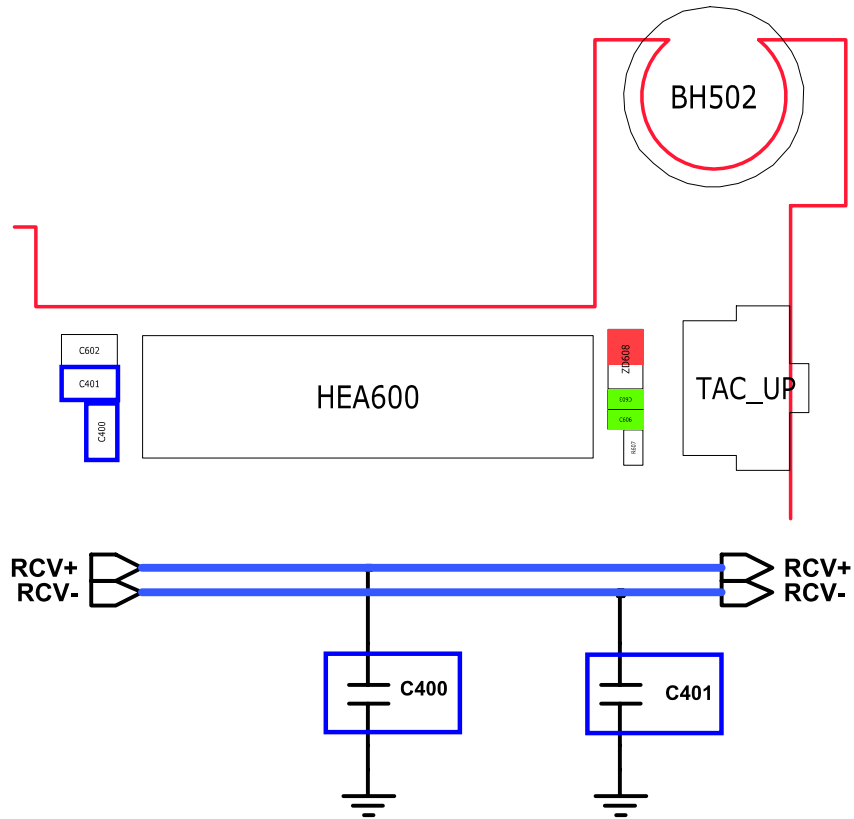
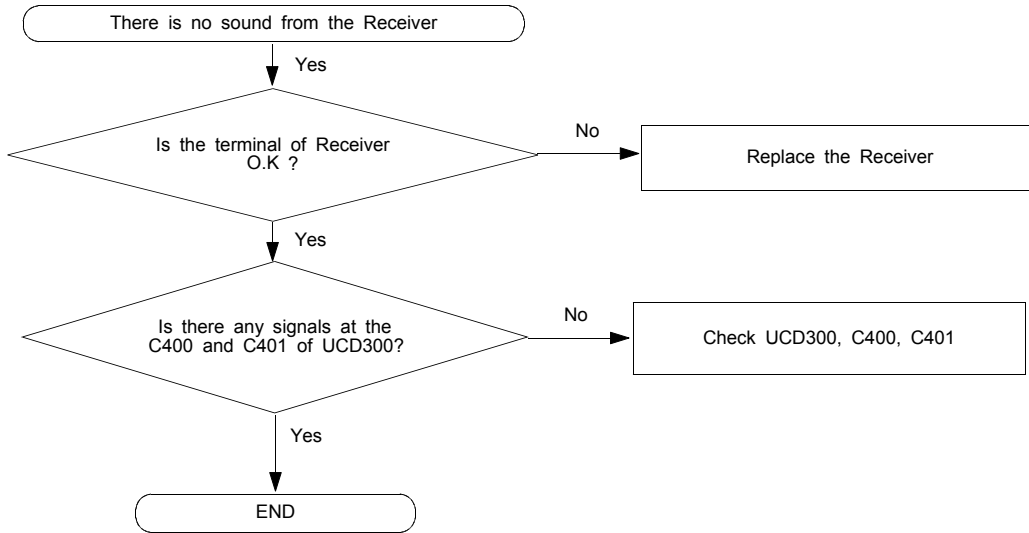

# Flow Chart of Troubleshooting

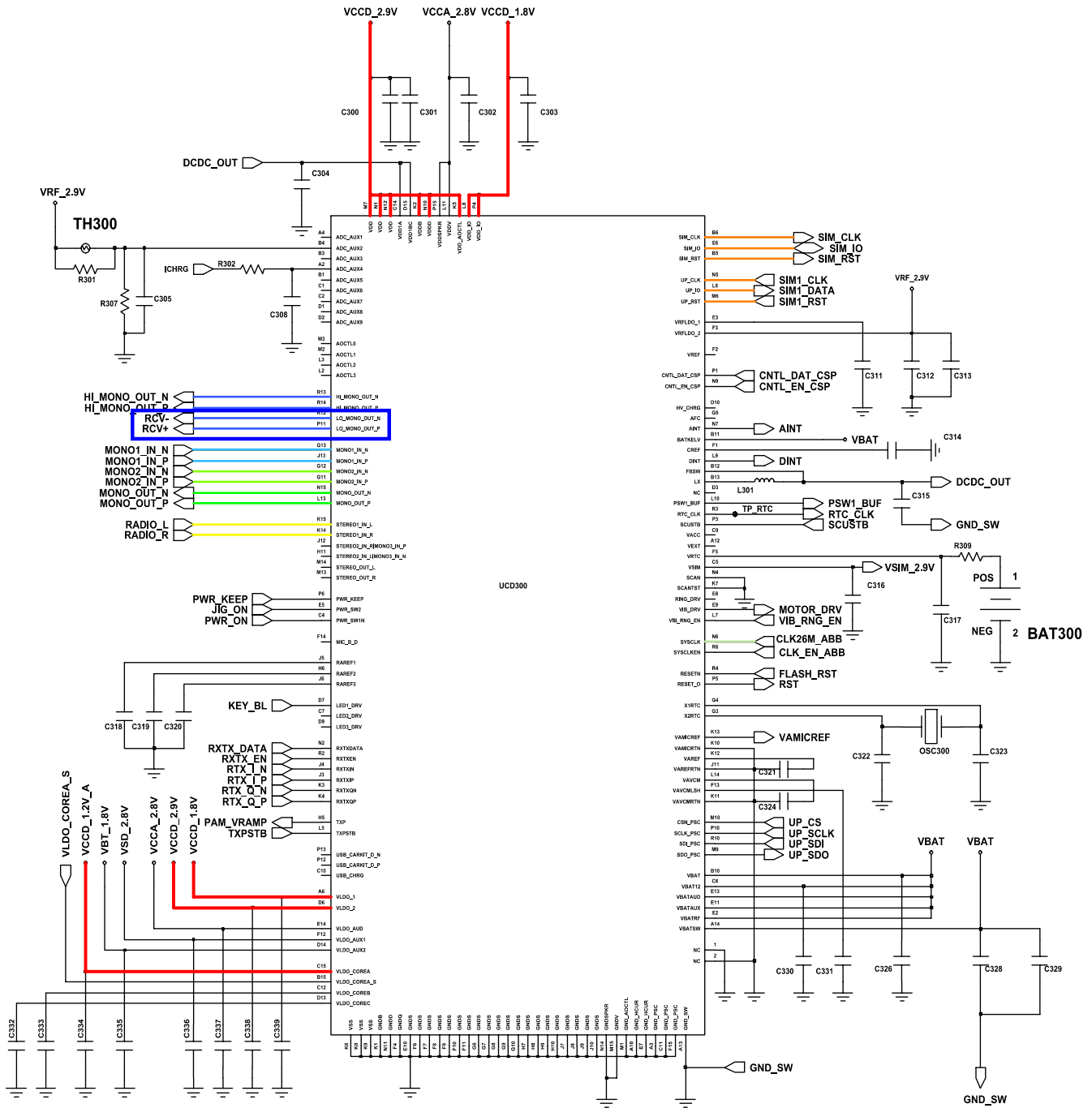

### 9-1-7. Speaker Part

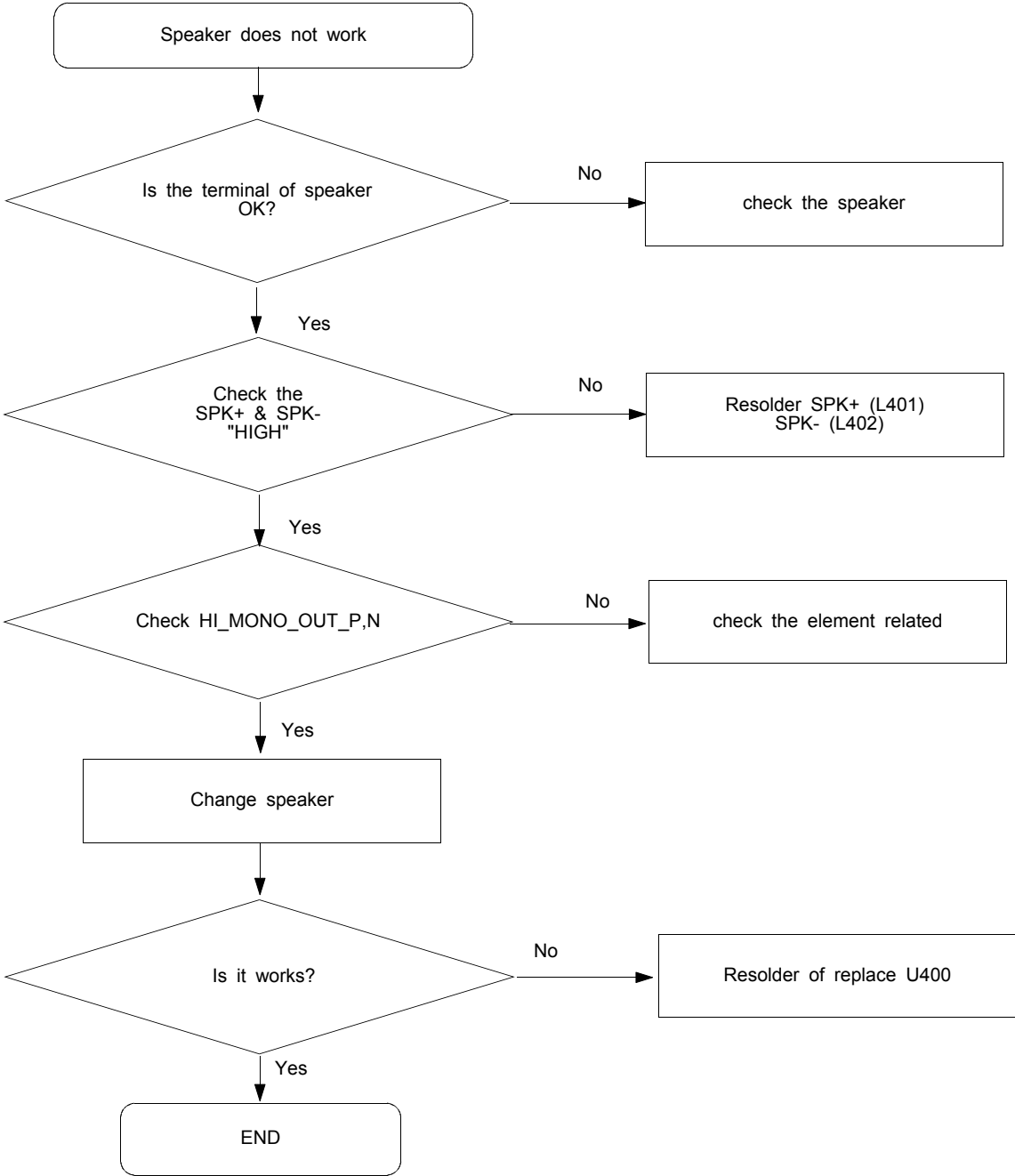

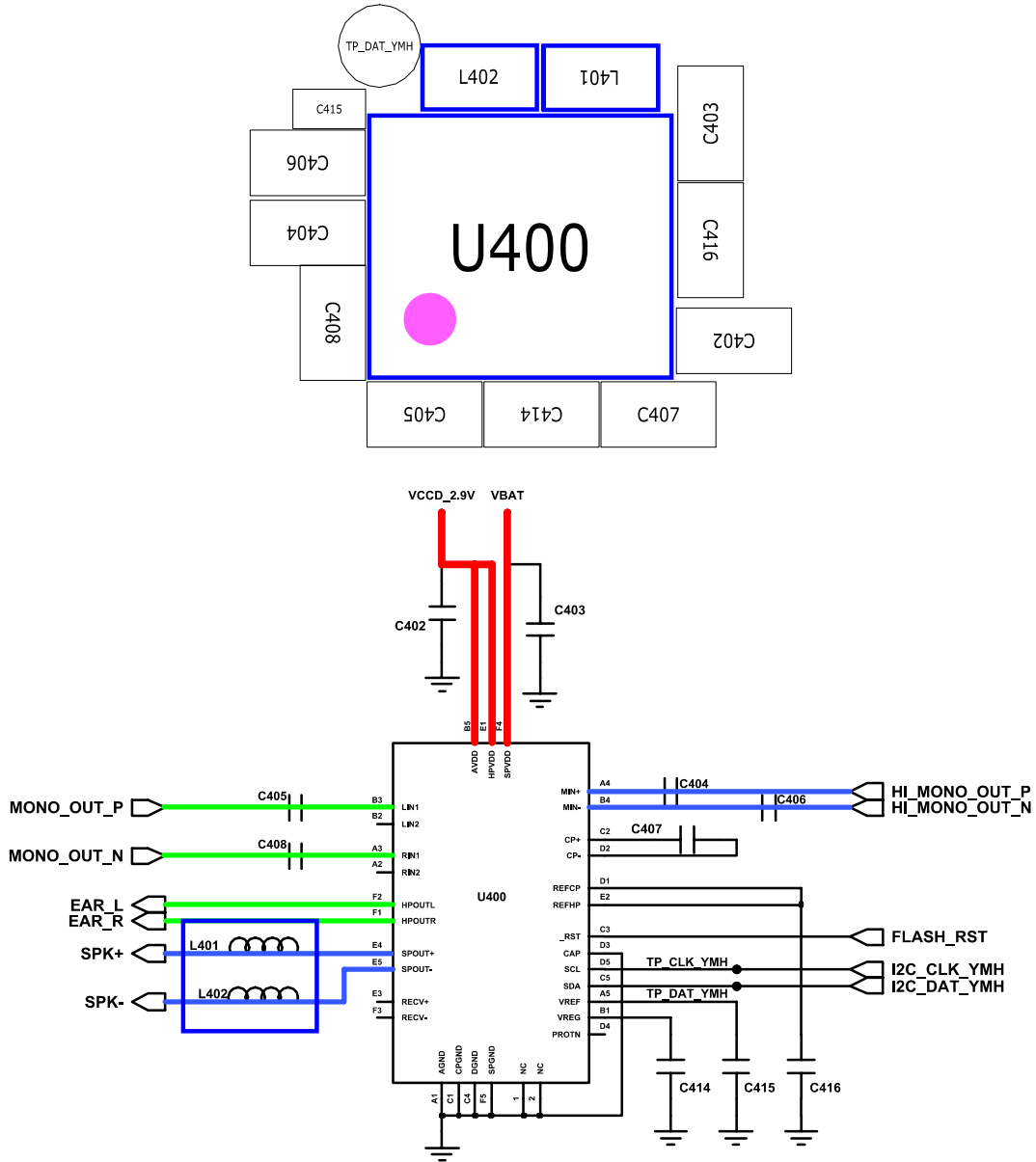

9-1-8. Camera part

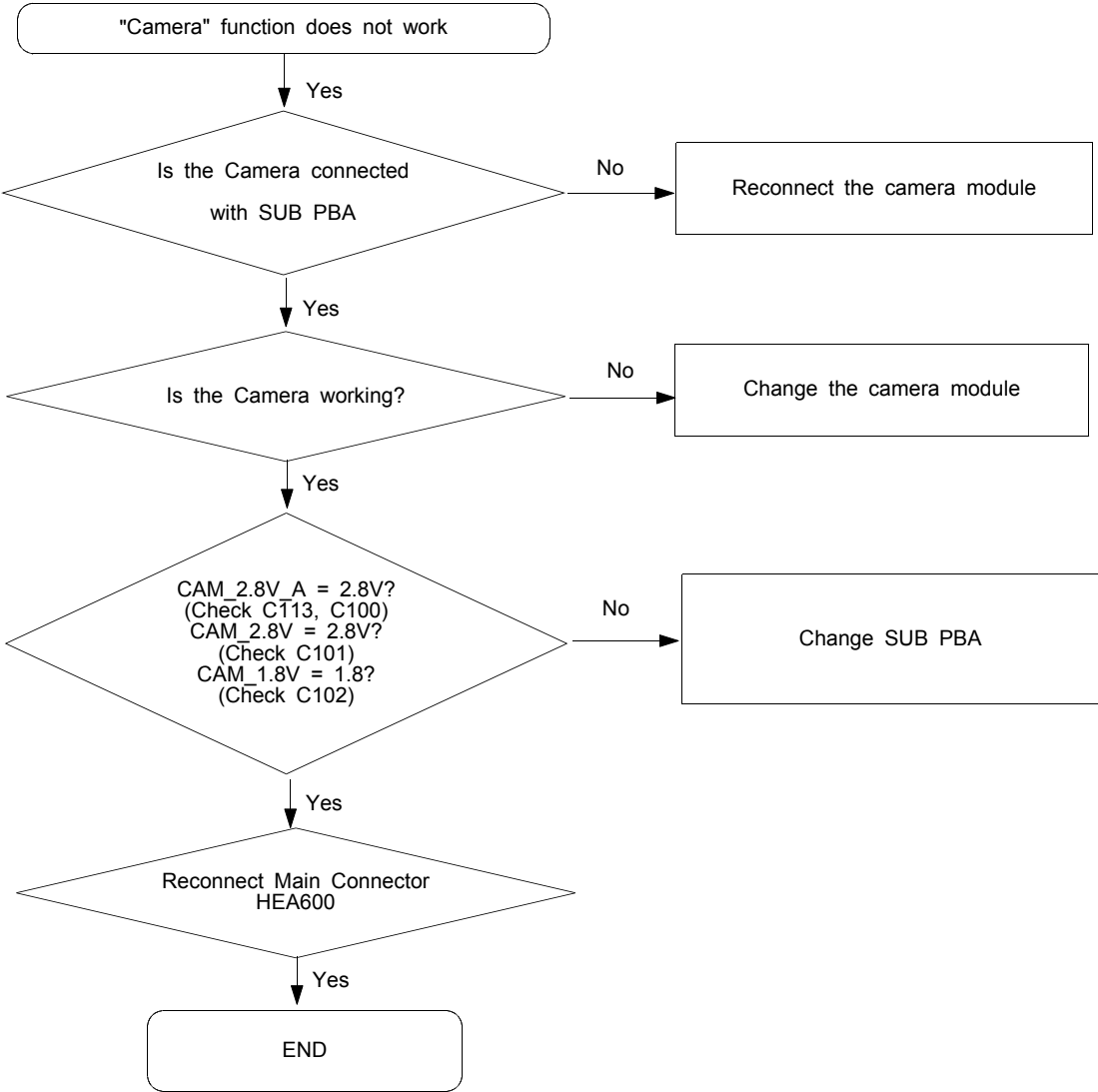

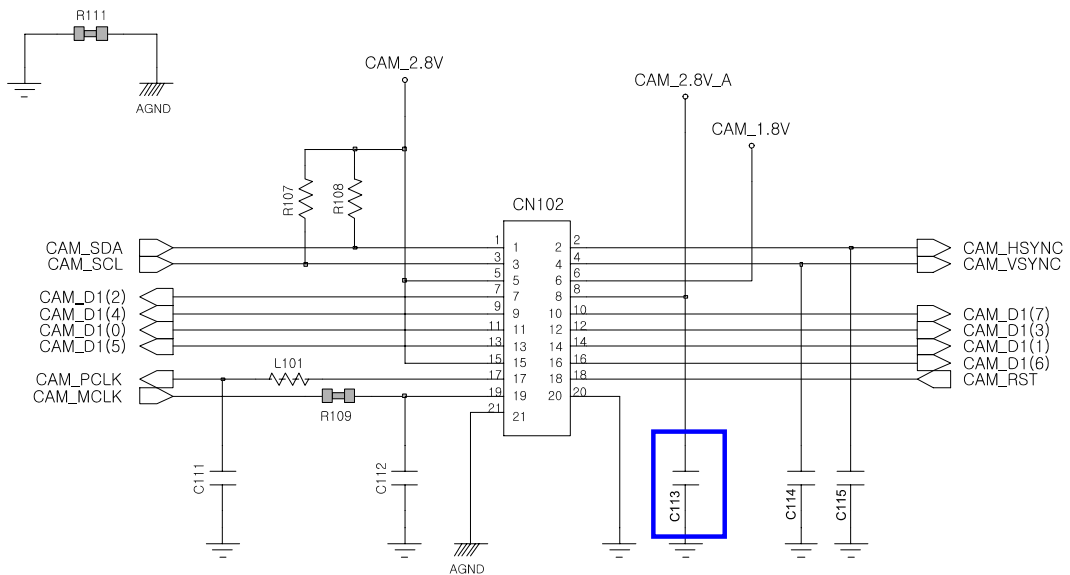
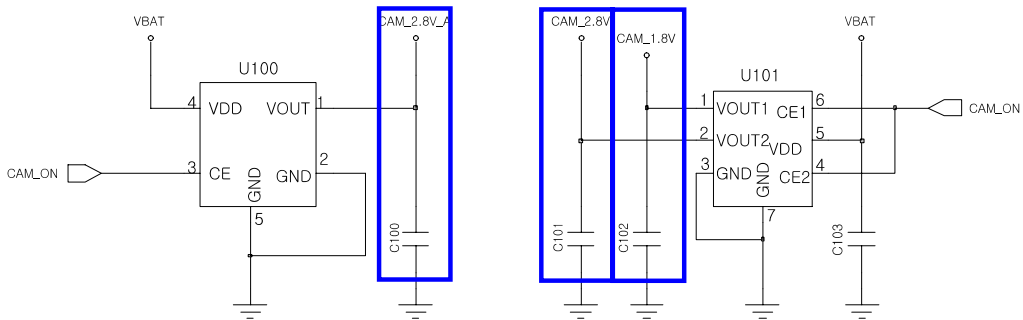
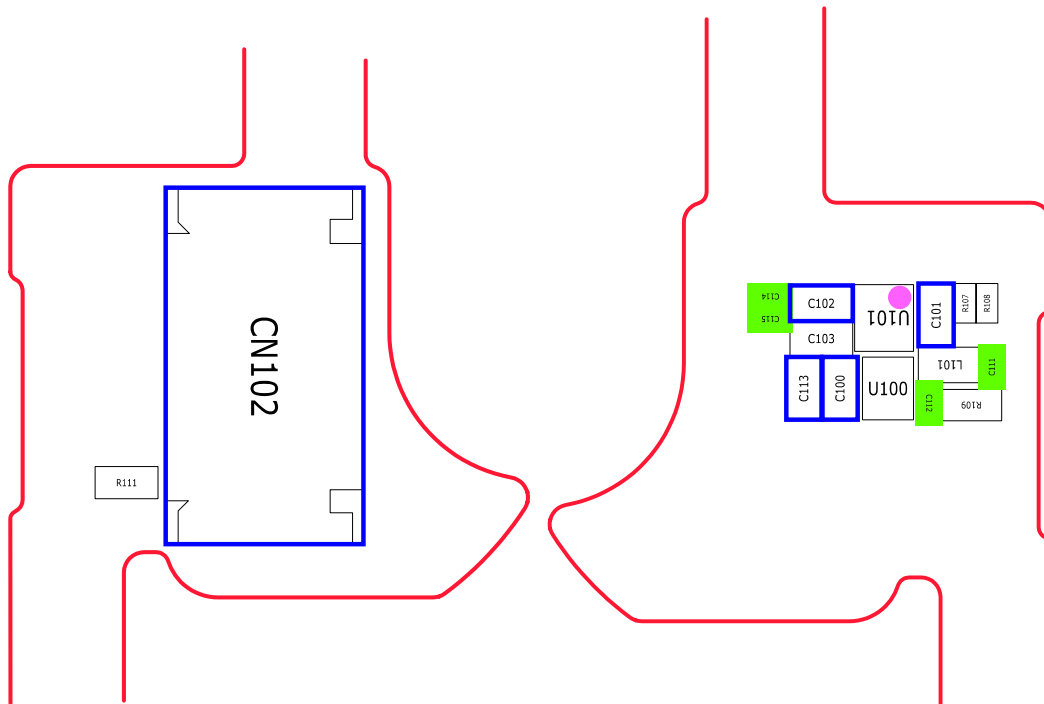



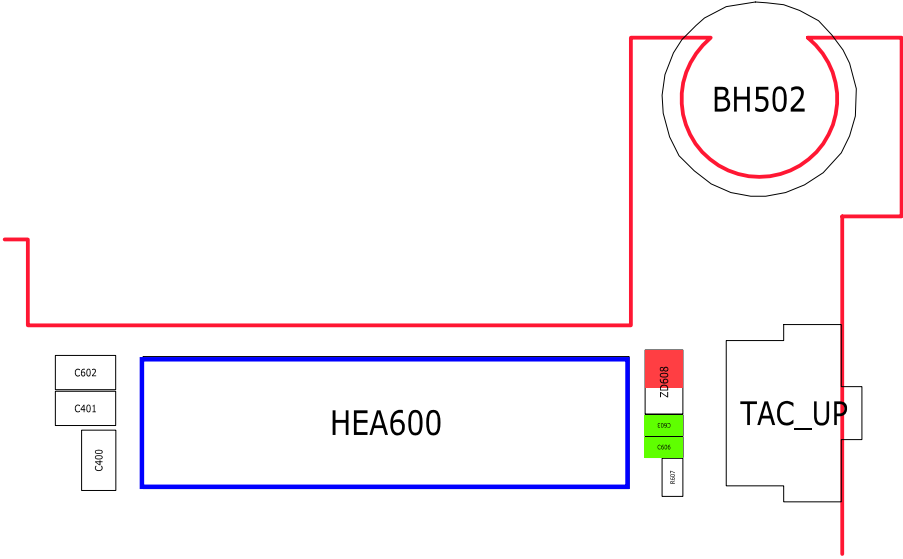

### 9-1-9. Radio part

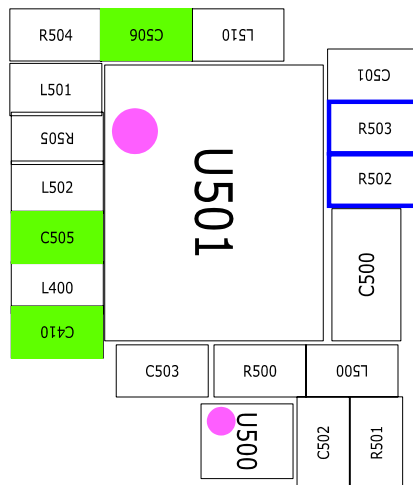
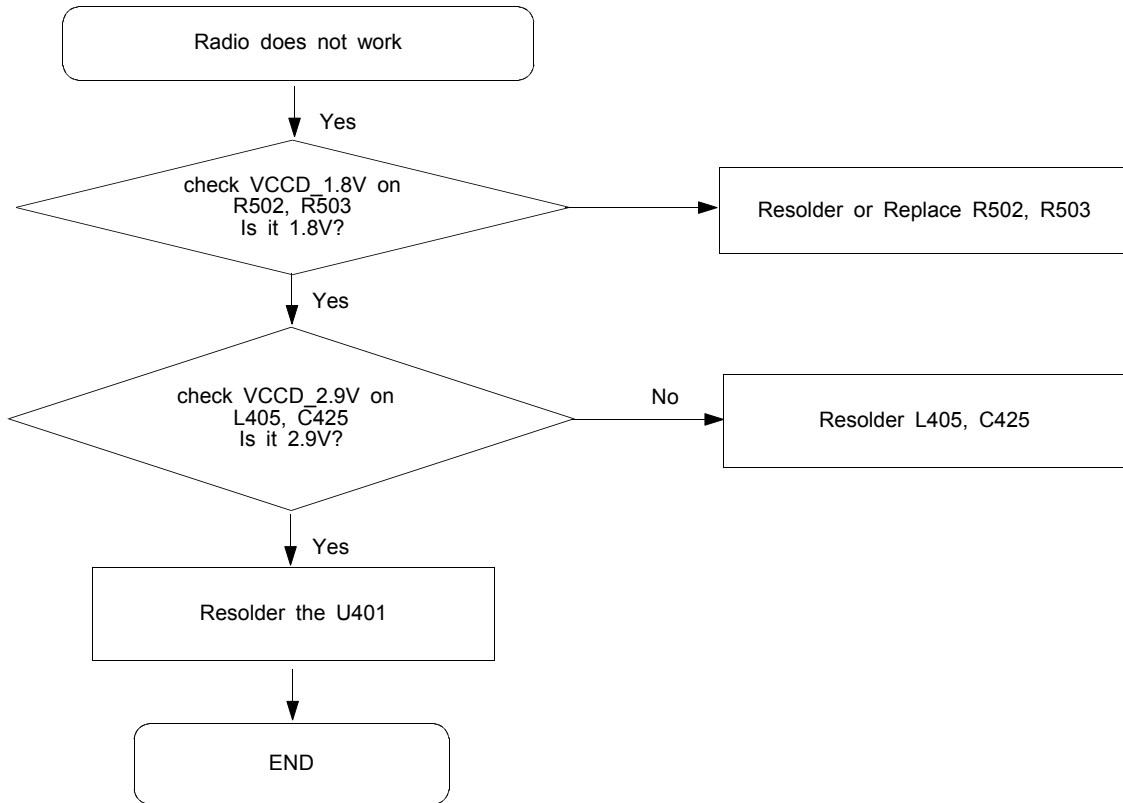

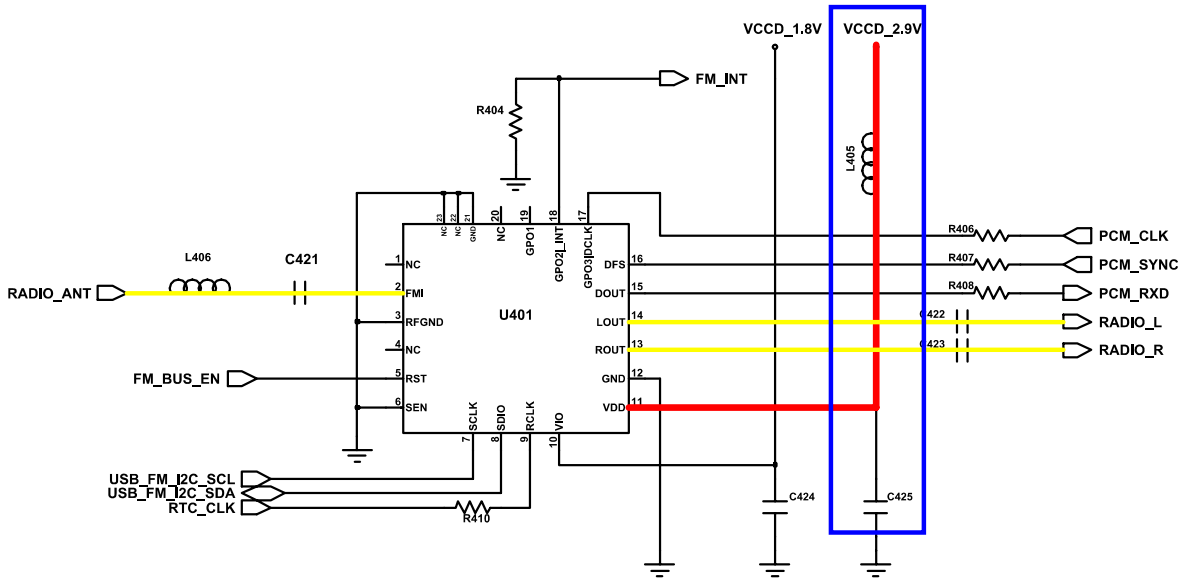
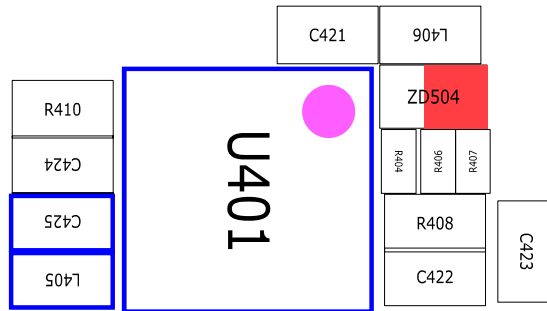
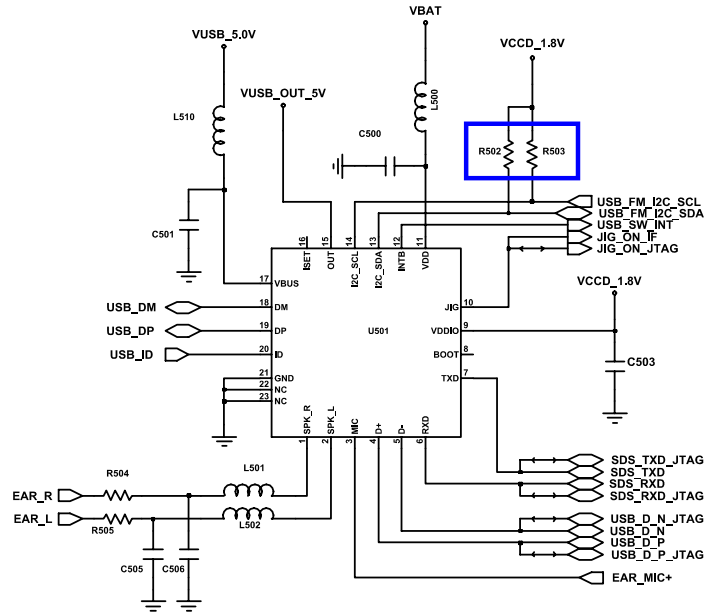

## 9-2. RF

### 9-2-1. EGSM RX

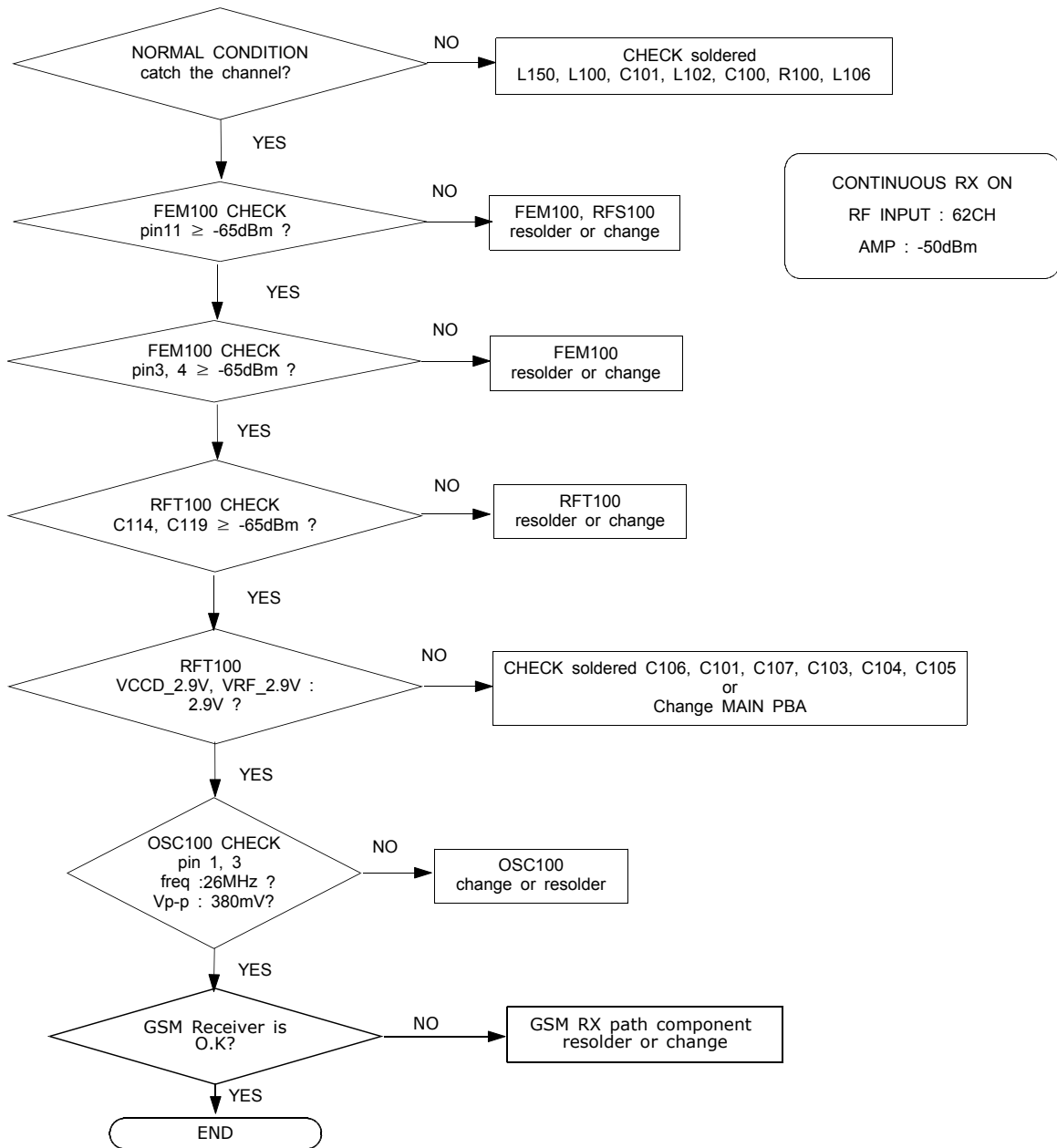

9-2-2. DCS RX

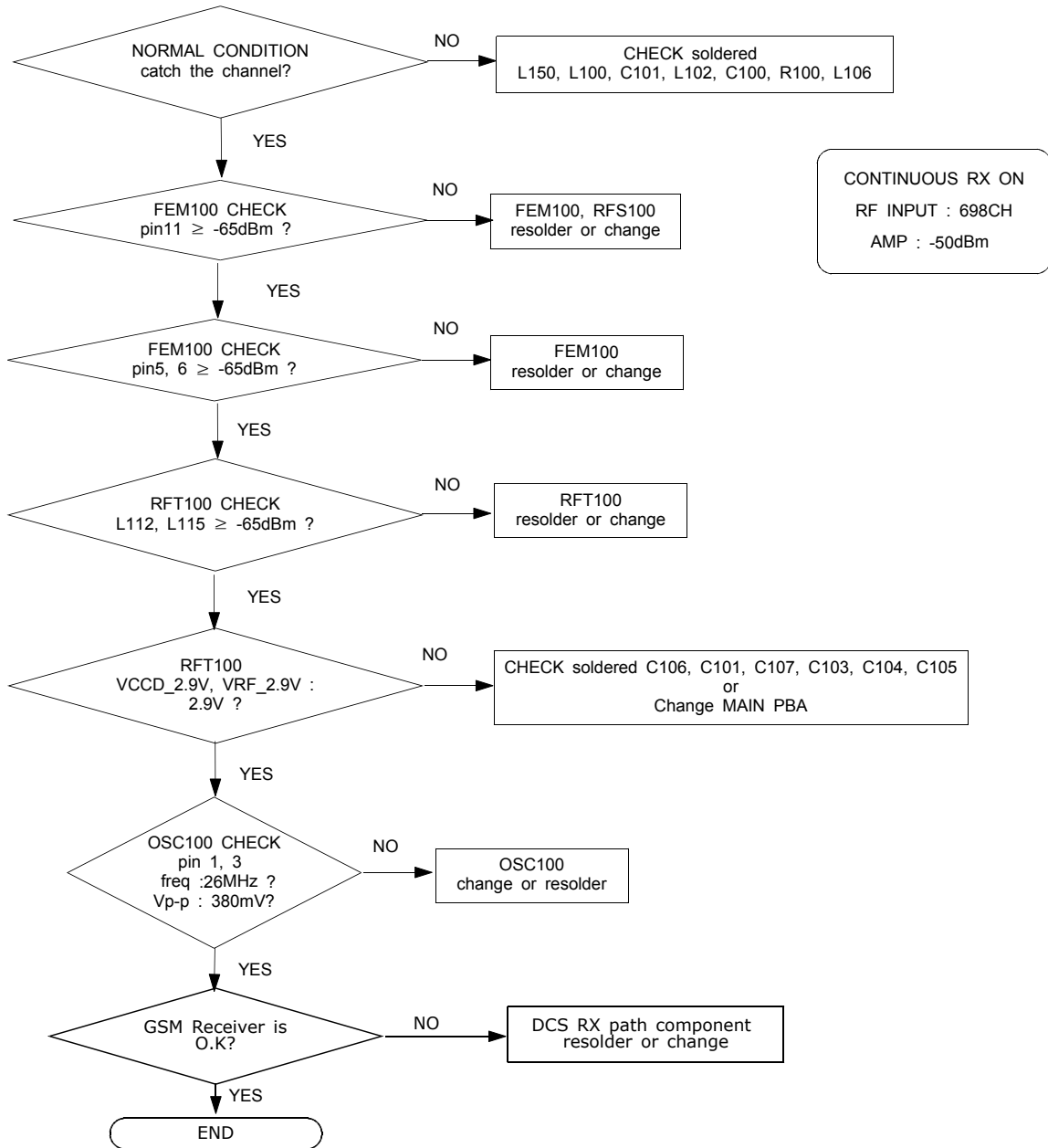

9-2-3. PCS RX

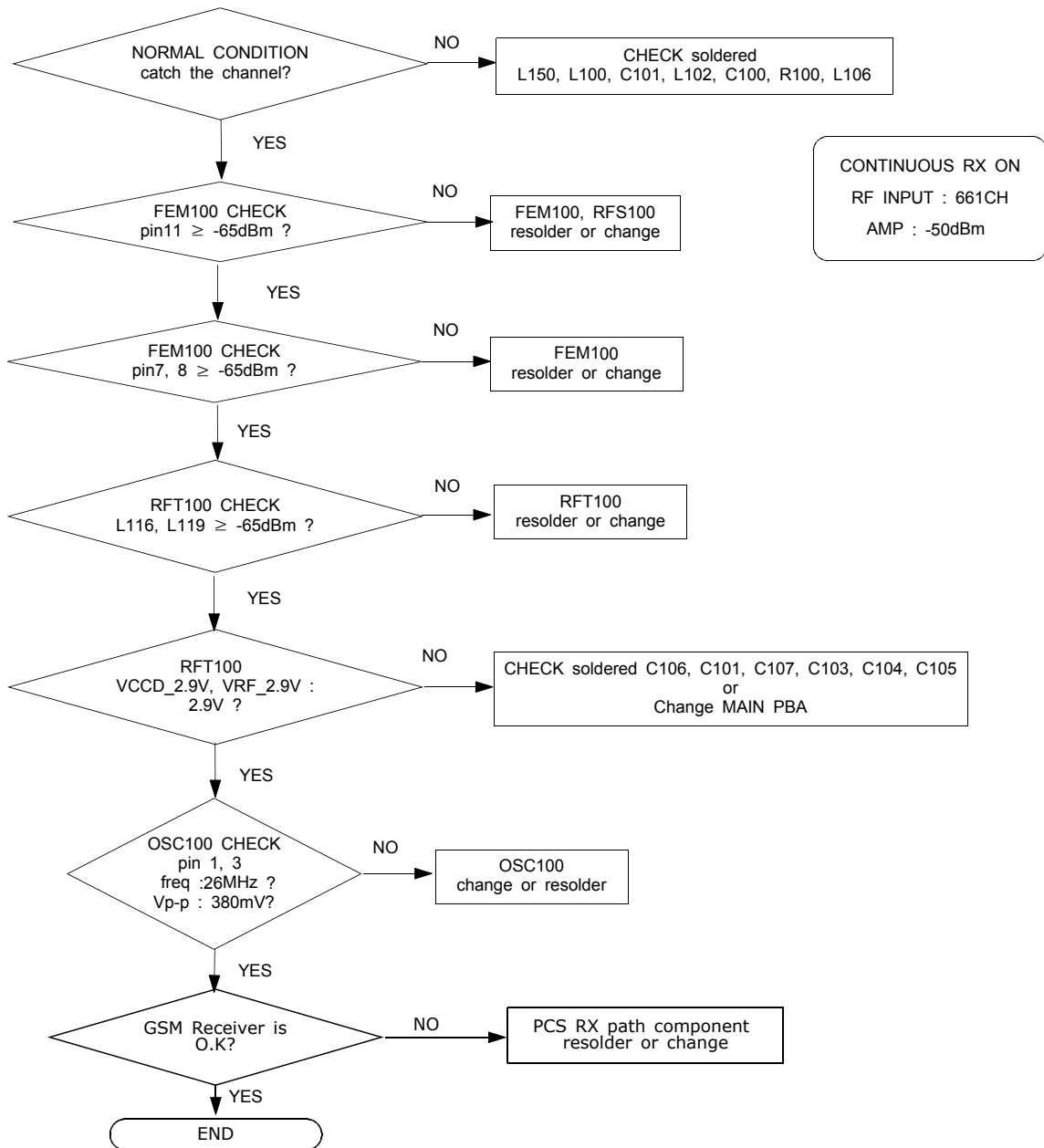

9-2-4. EGSM TX

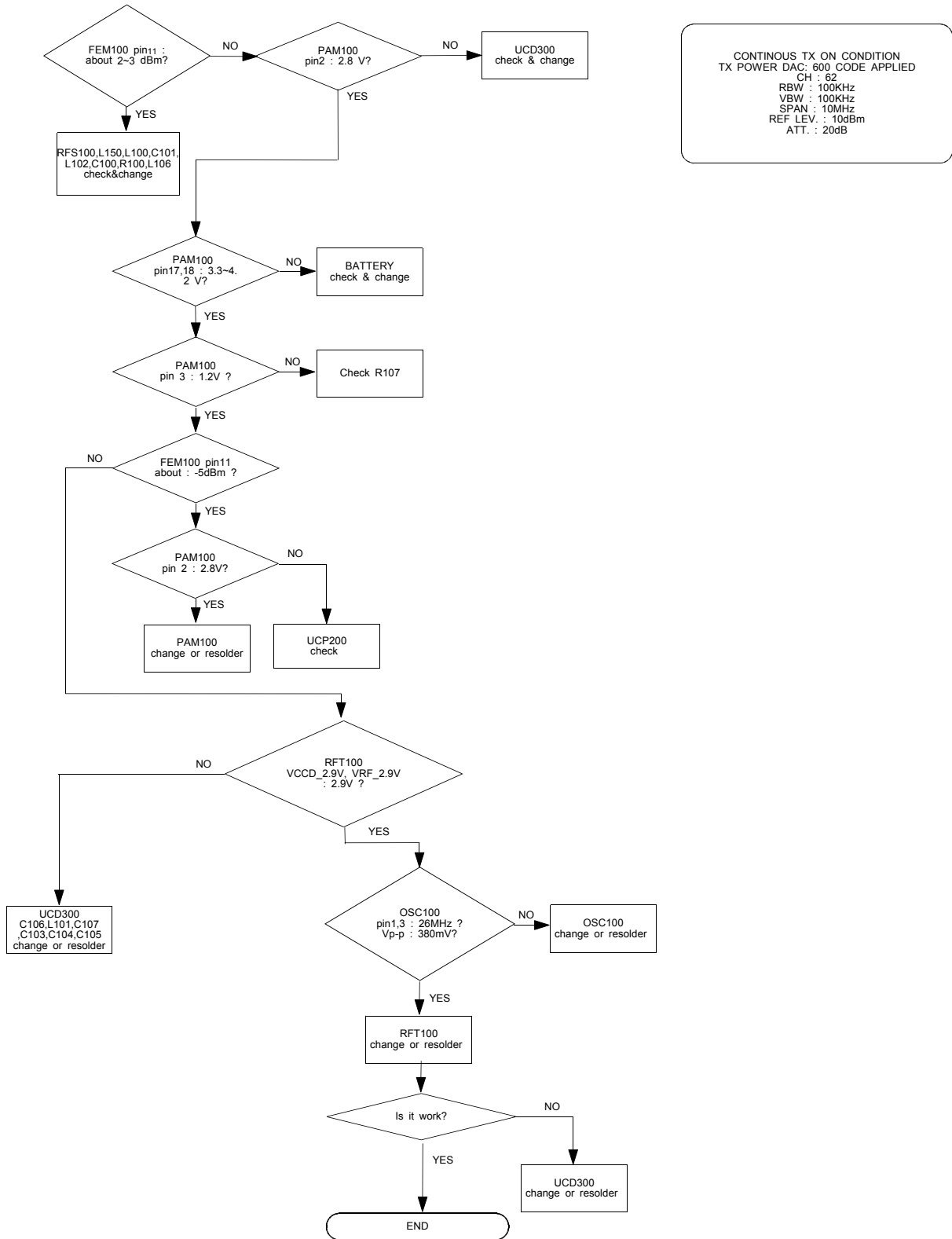

### 9-2-5. DCS TX

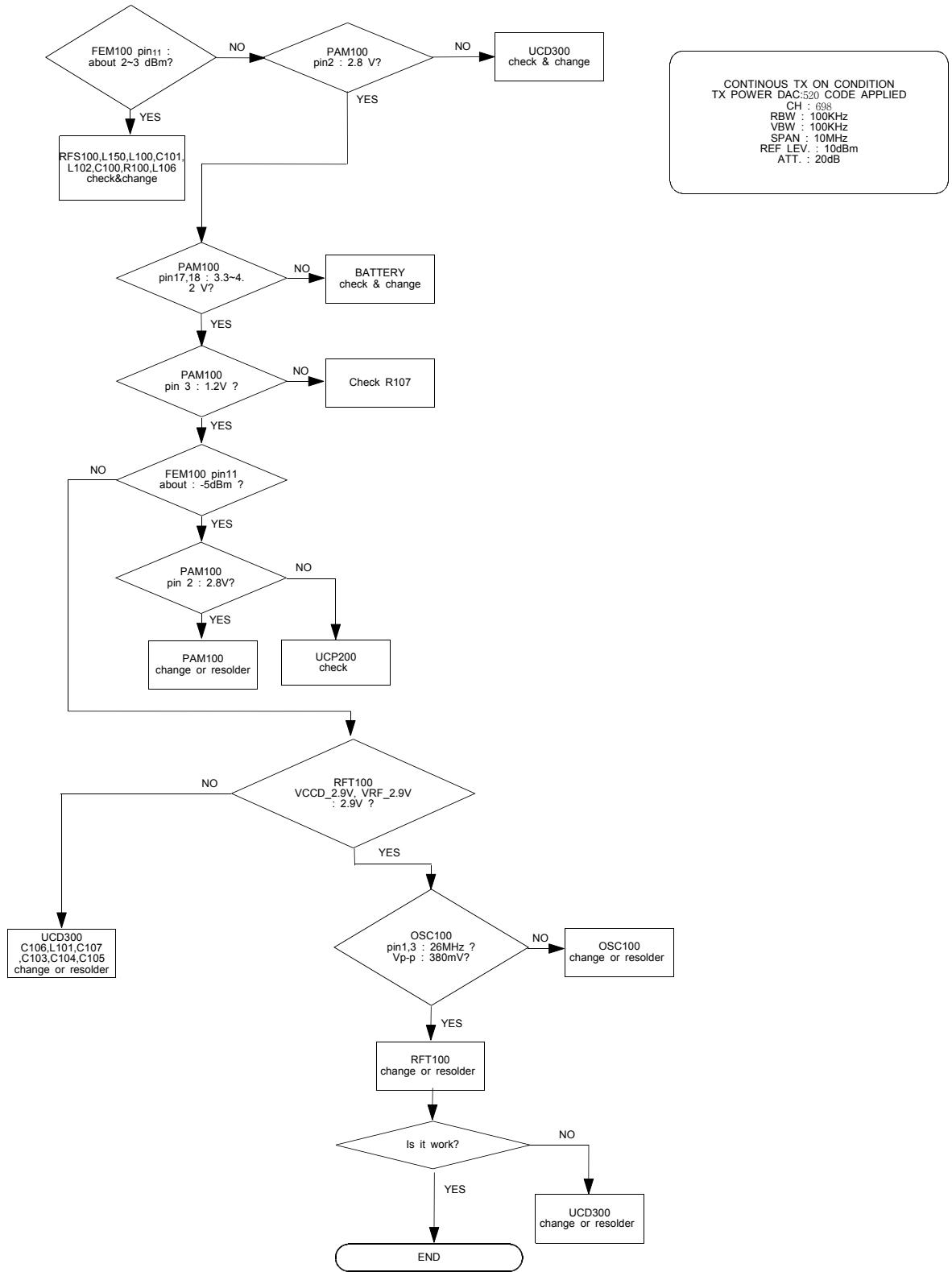



9-2-6. PCS TX

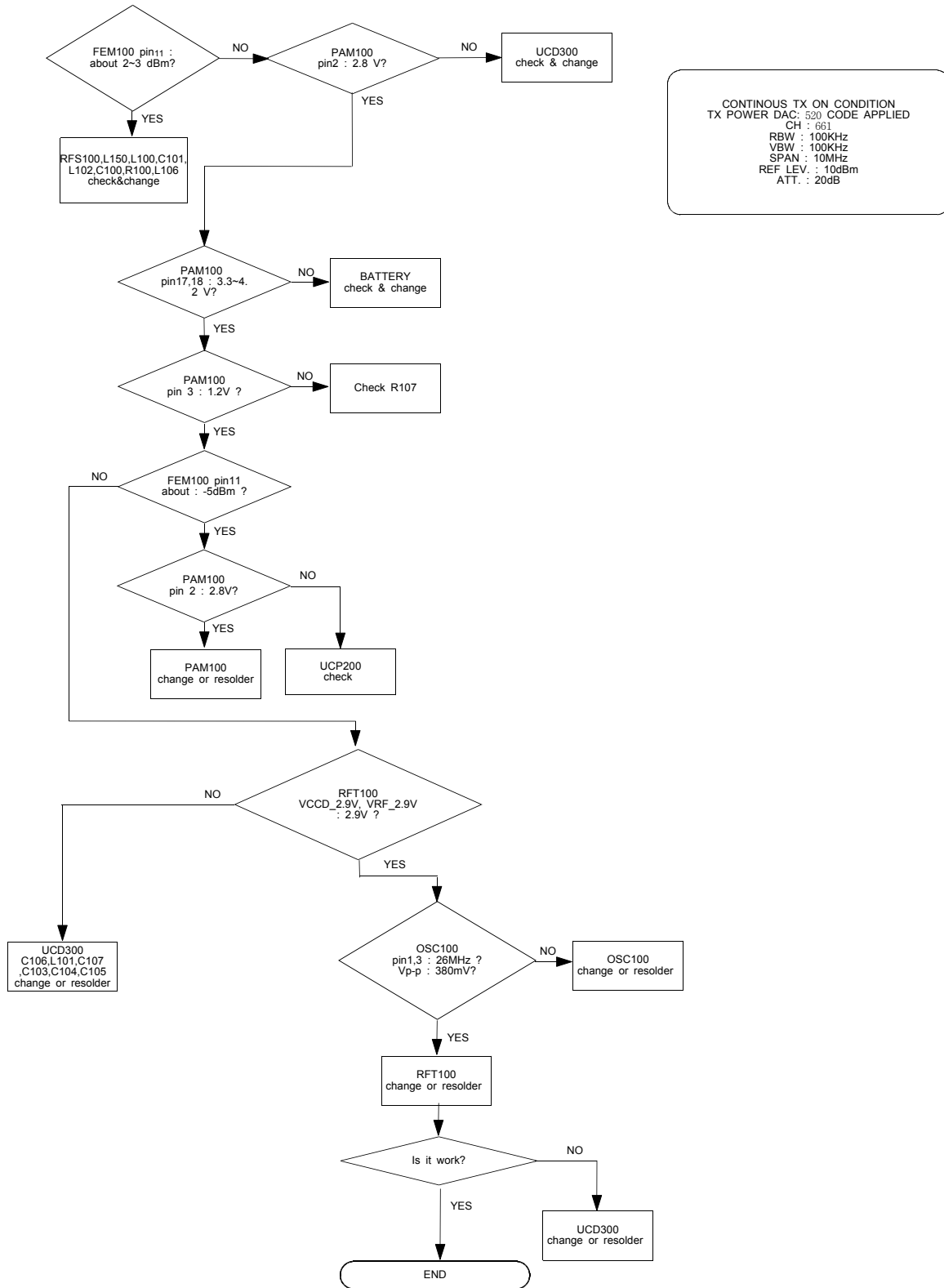

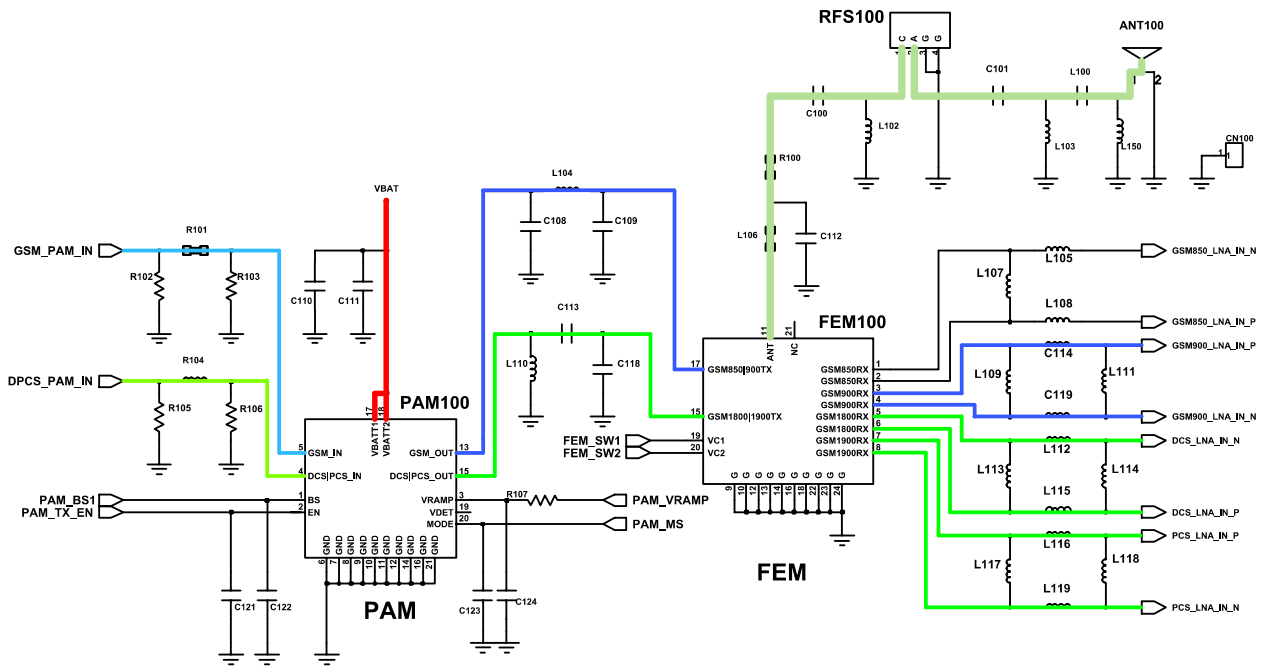

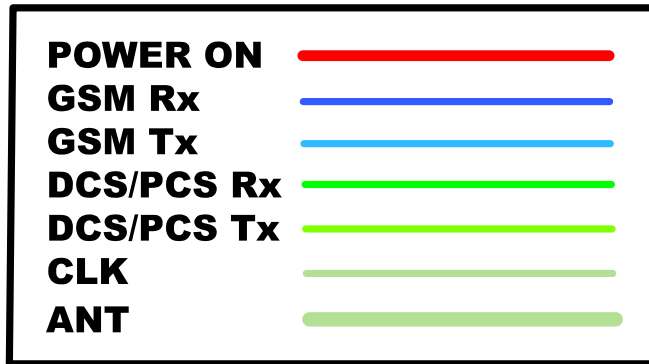
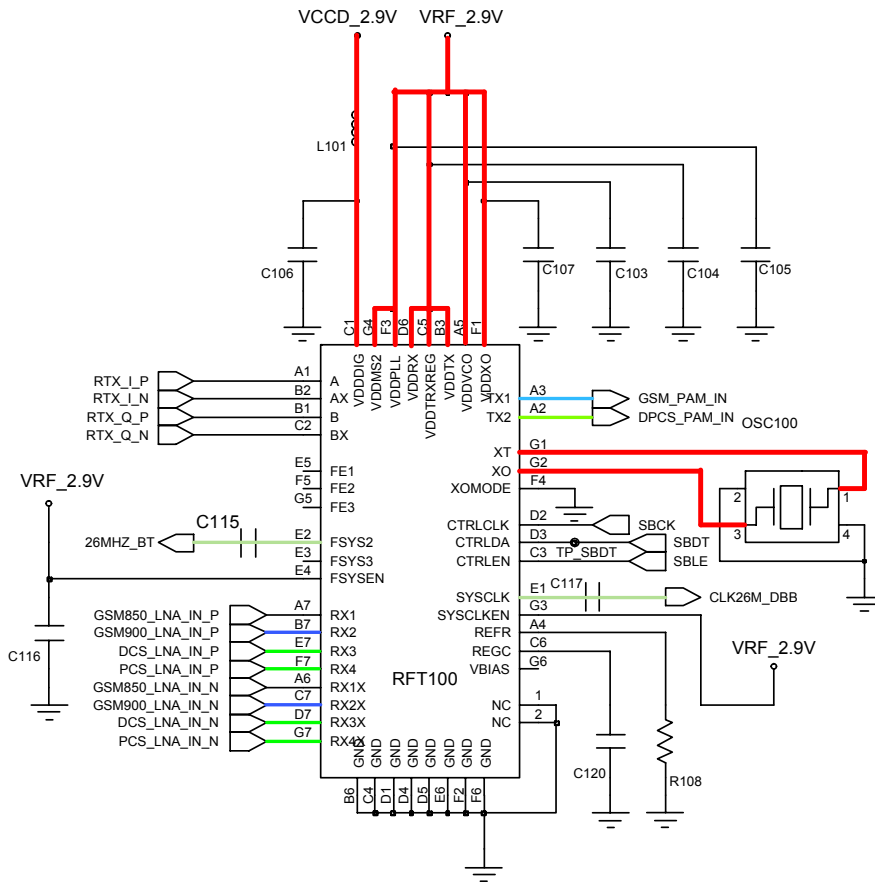

### 9-2-7. Bluetooth part

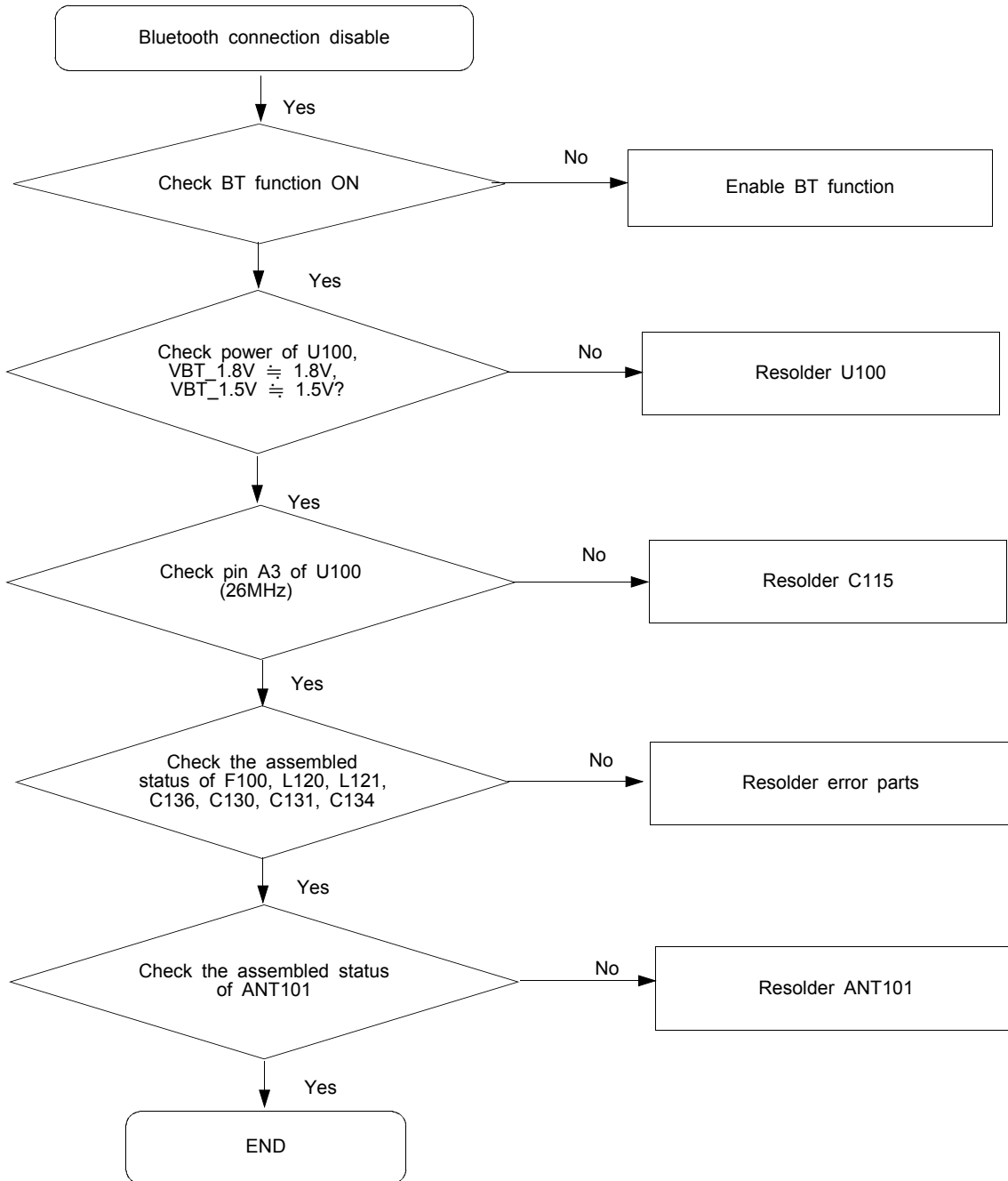

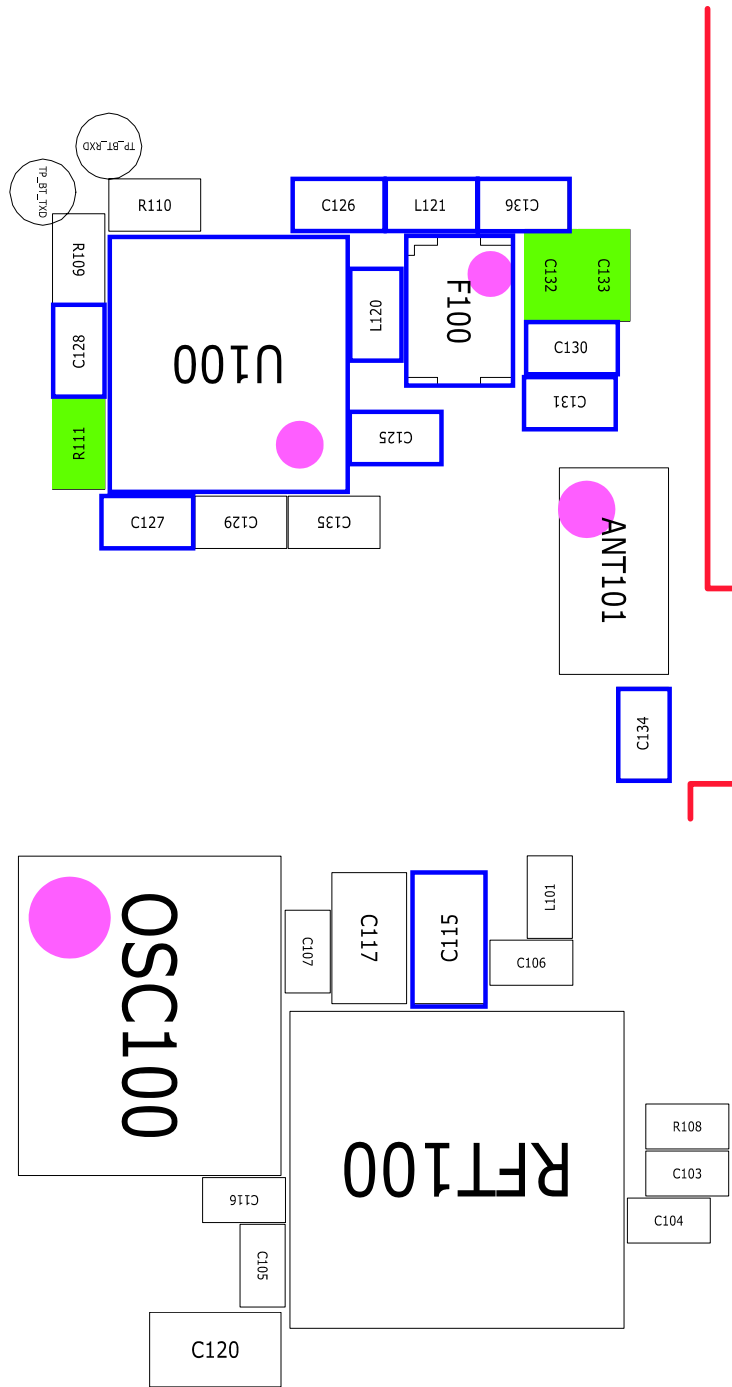

Flow Chart of Troubleshooting

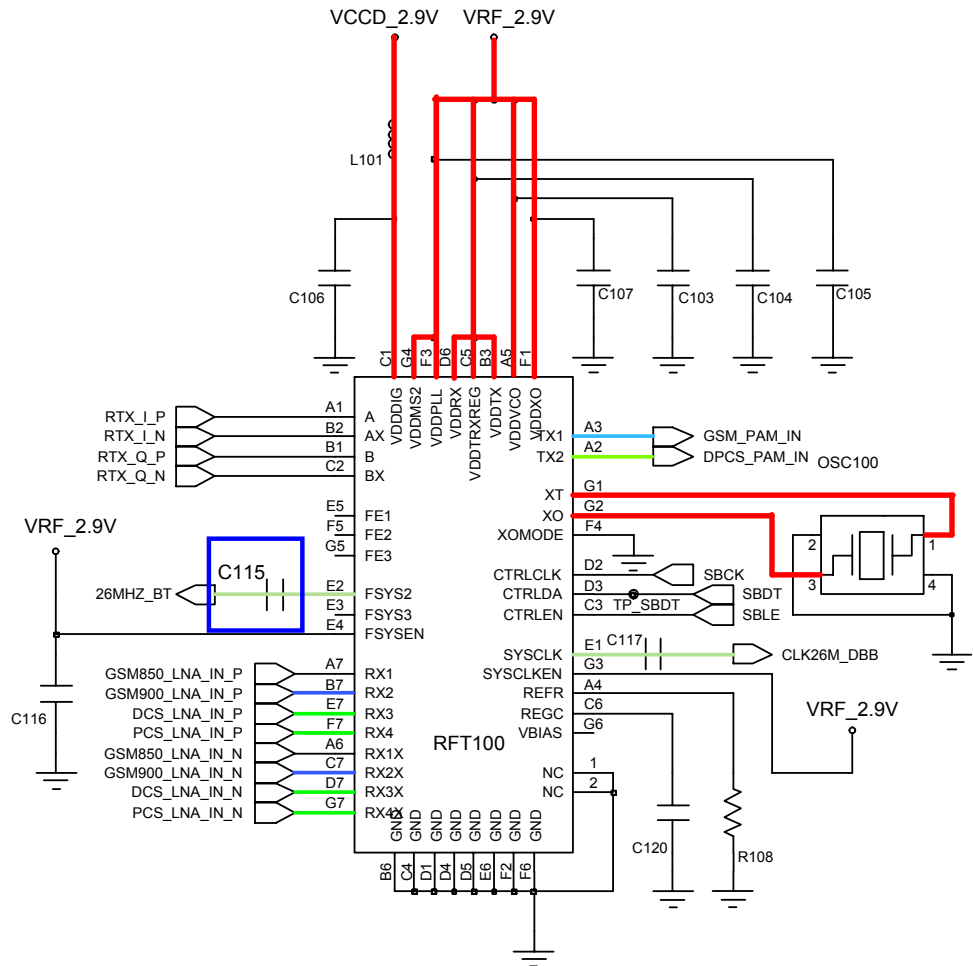
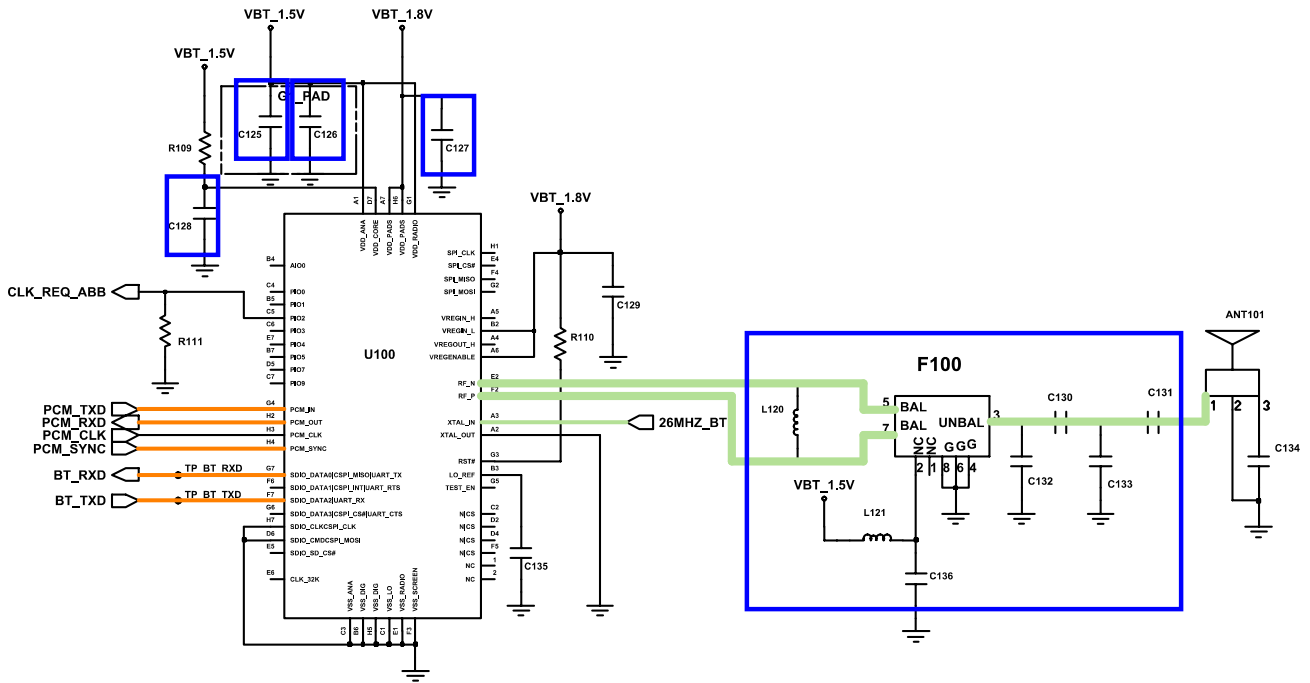

# 7. Block Diagrams

## 7-1. Block Diagram

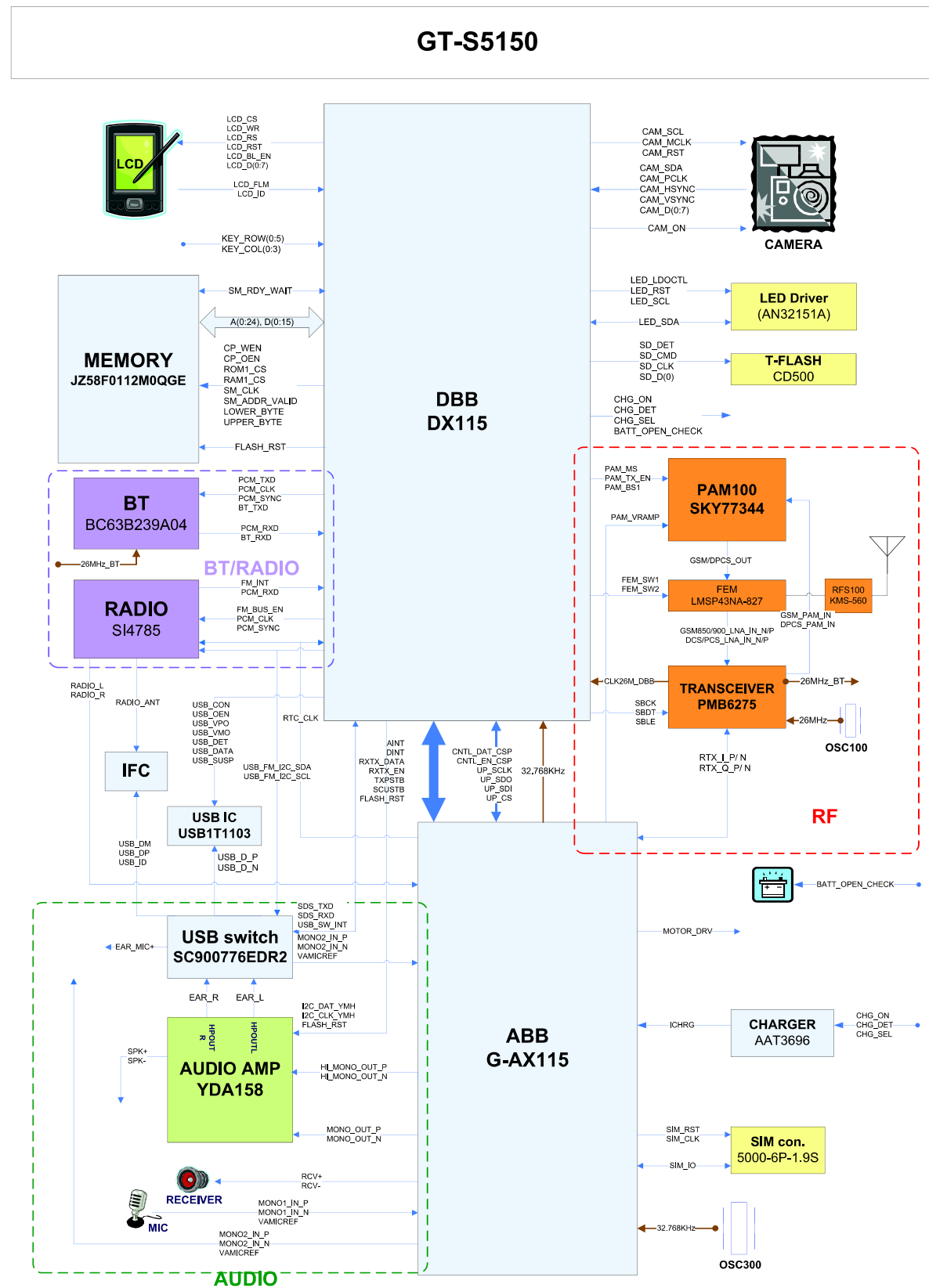

7-2. RF Block Diagram

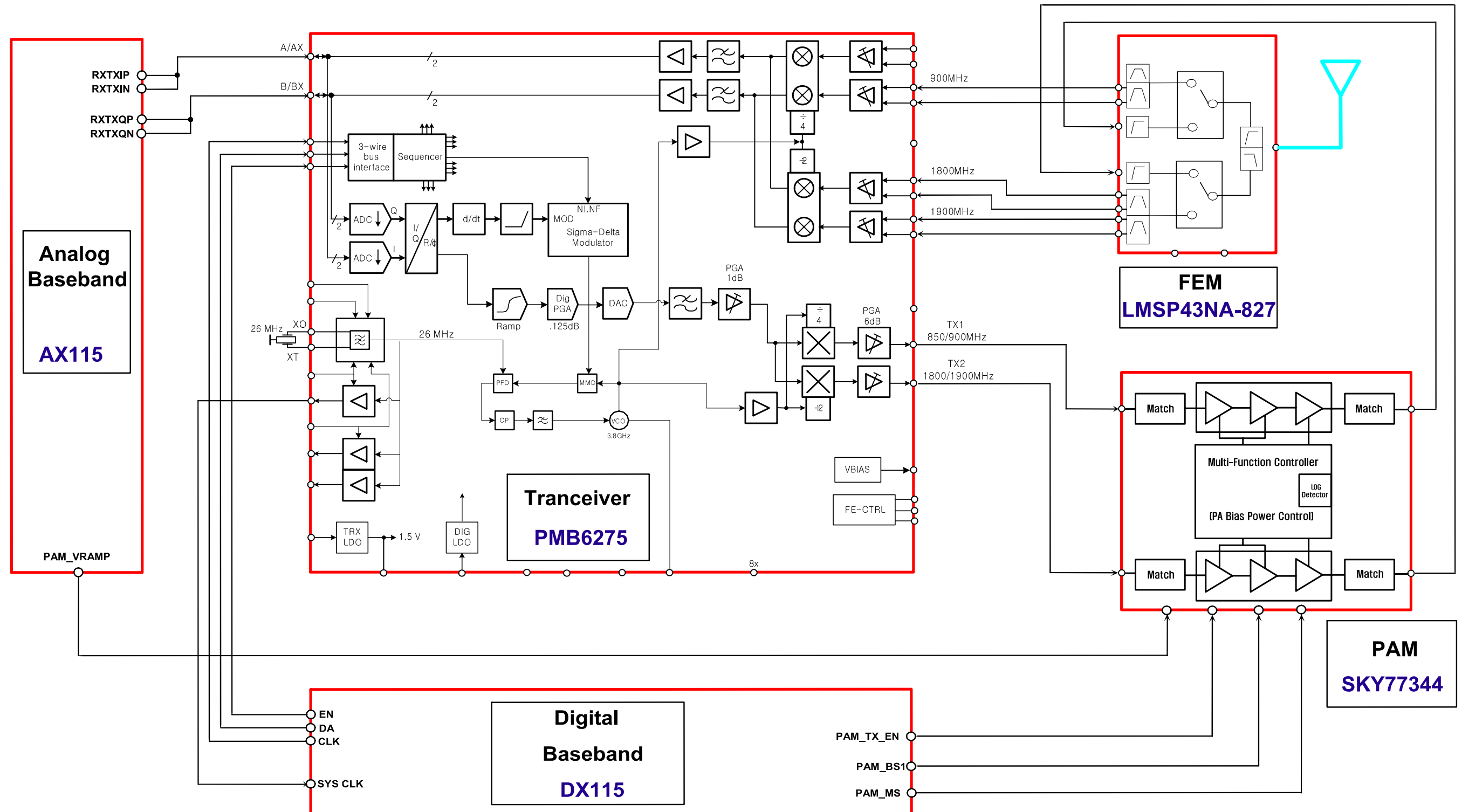



7-3. Audio Block Diagram

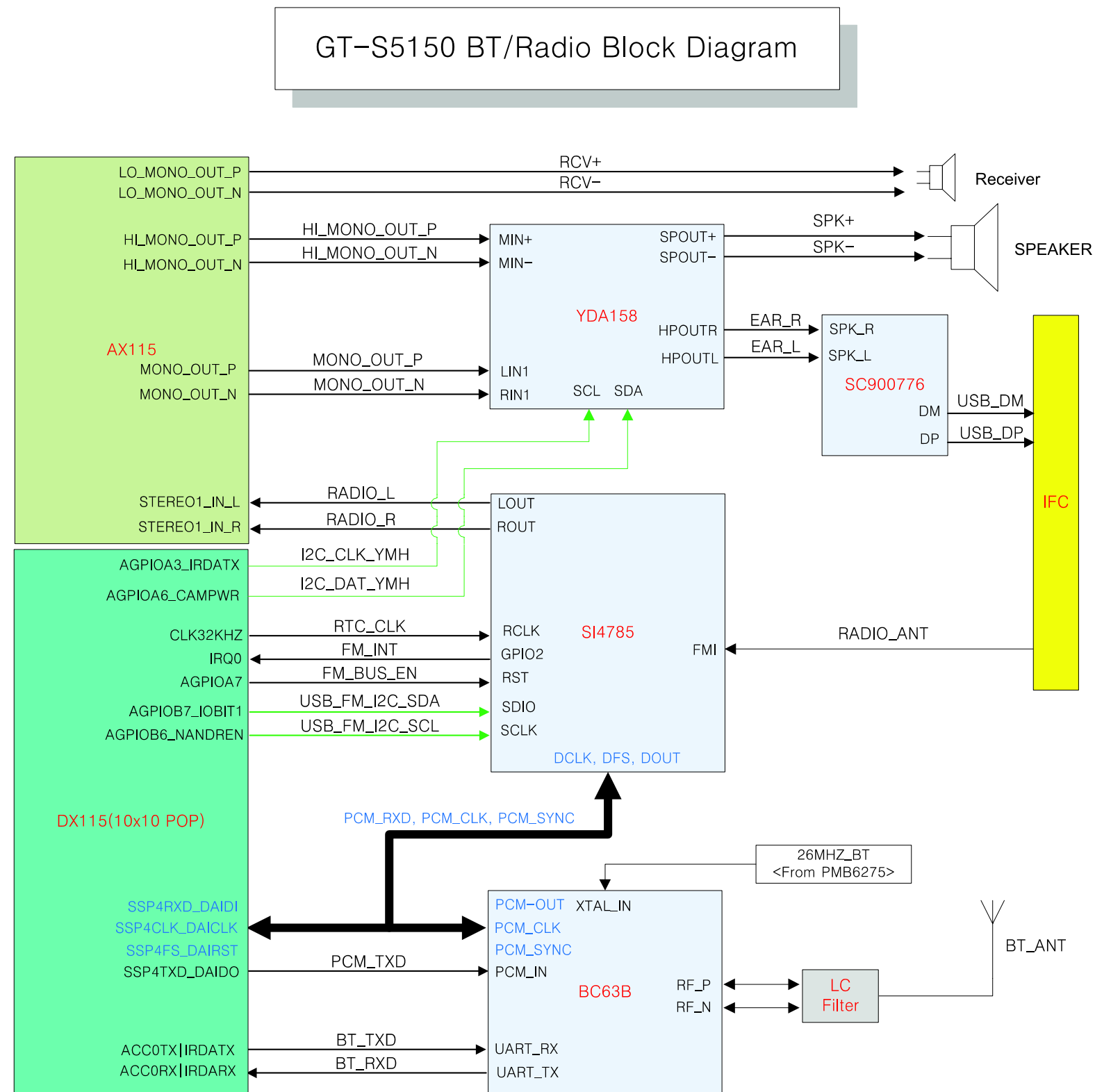

# 8. PCB Diagrams

[Main top view]



[Main Bottom view]

