

8. Level 3 Repair

8-1. Block Diagram

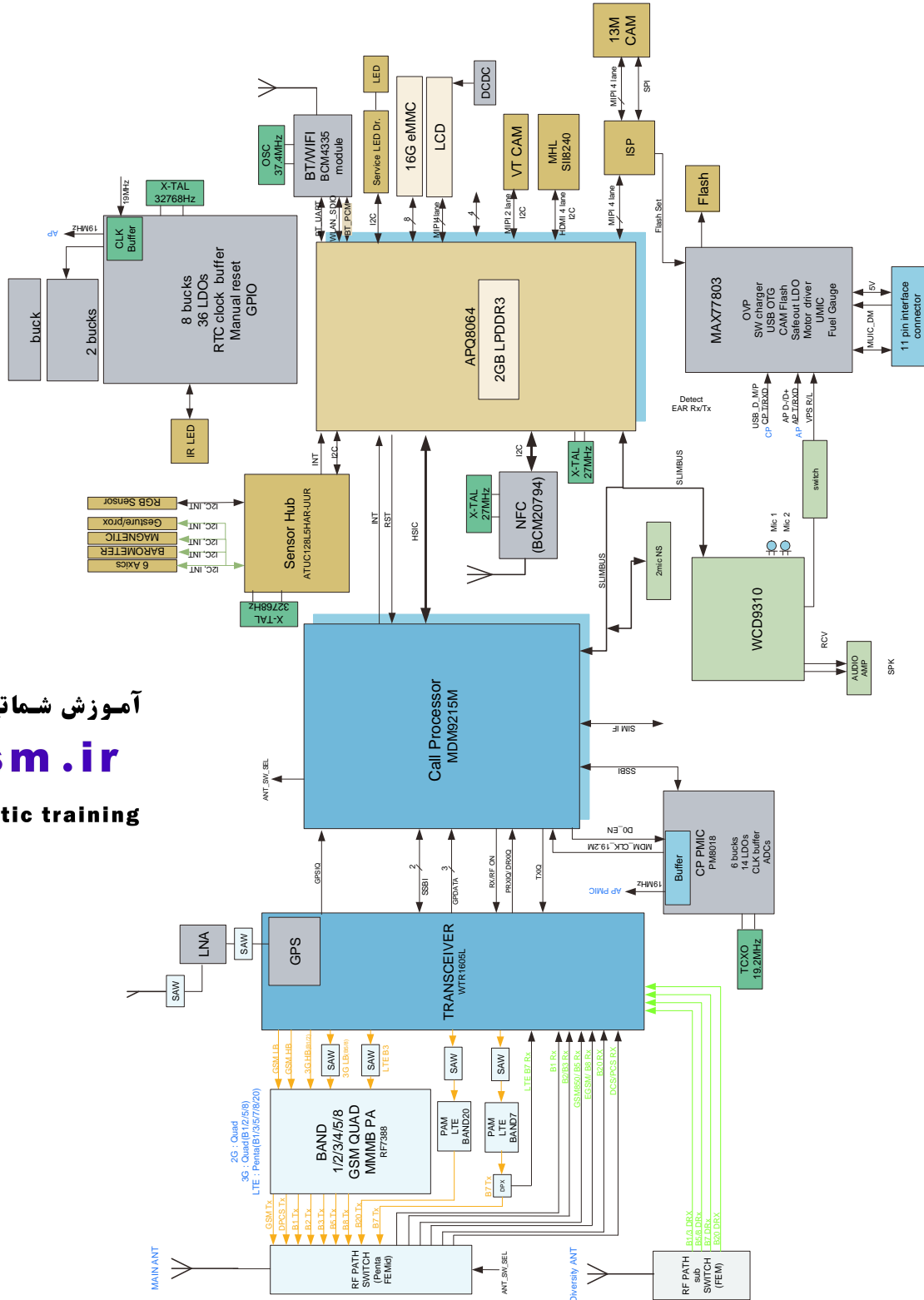

آموزش شماتیک و نقشه خوانی

iranbsm.ir

Mobile schematic training

8-2. PCB Diagrams
8-2-1. Main PCB Top

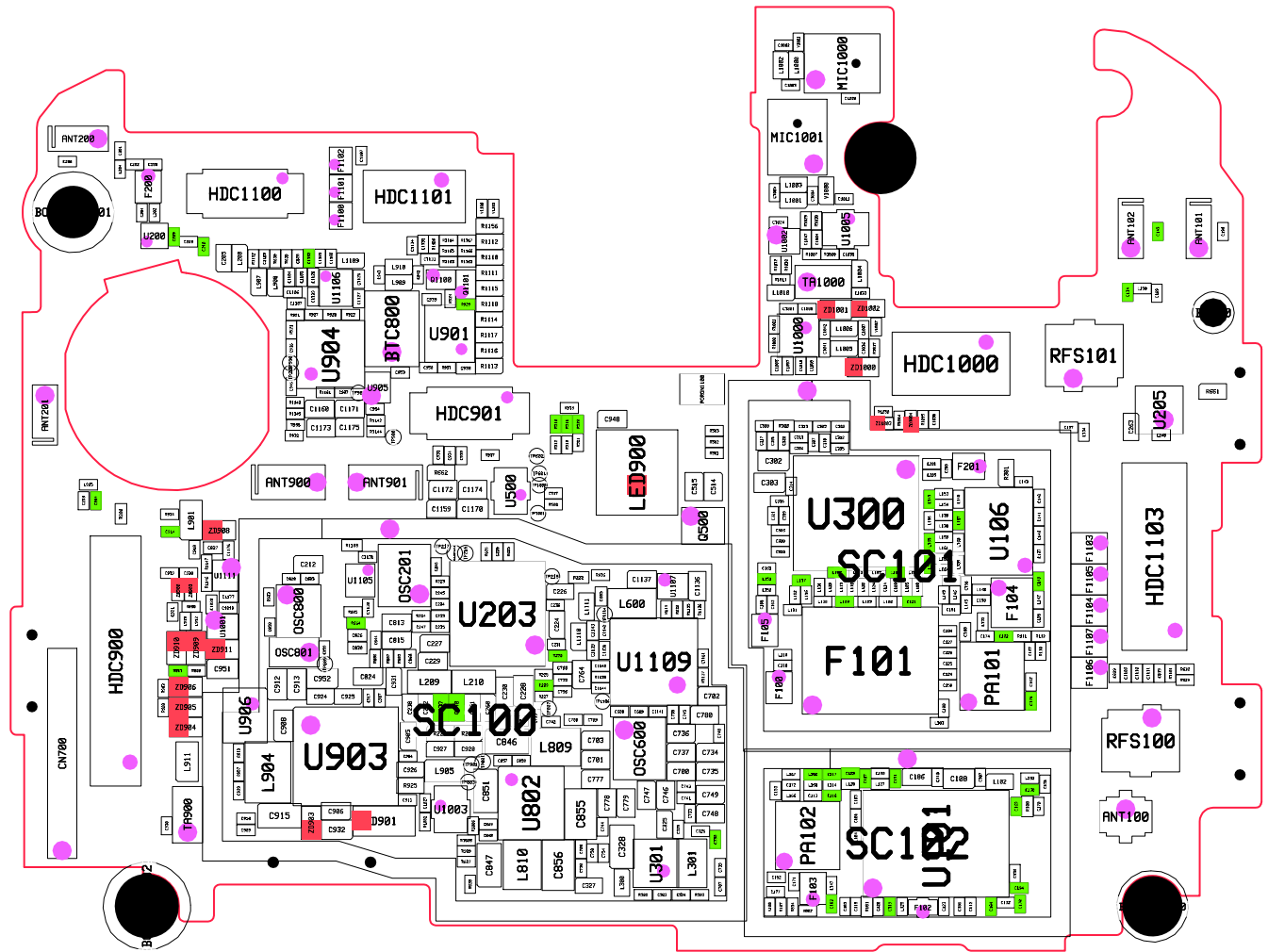

8-2-2. Bottom

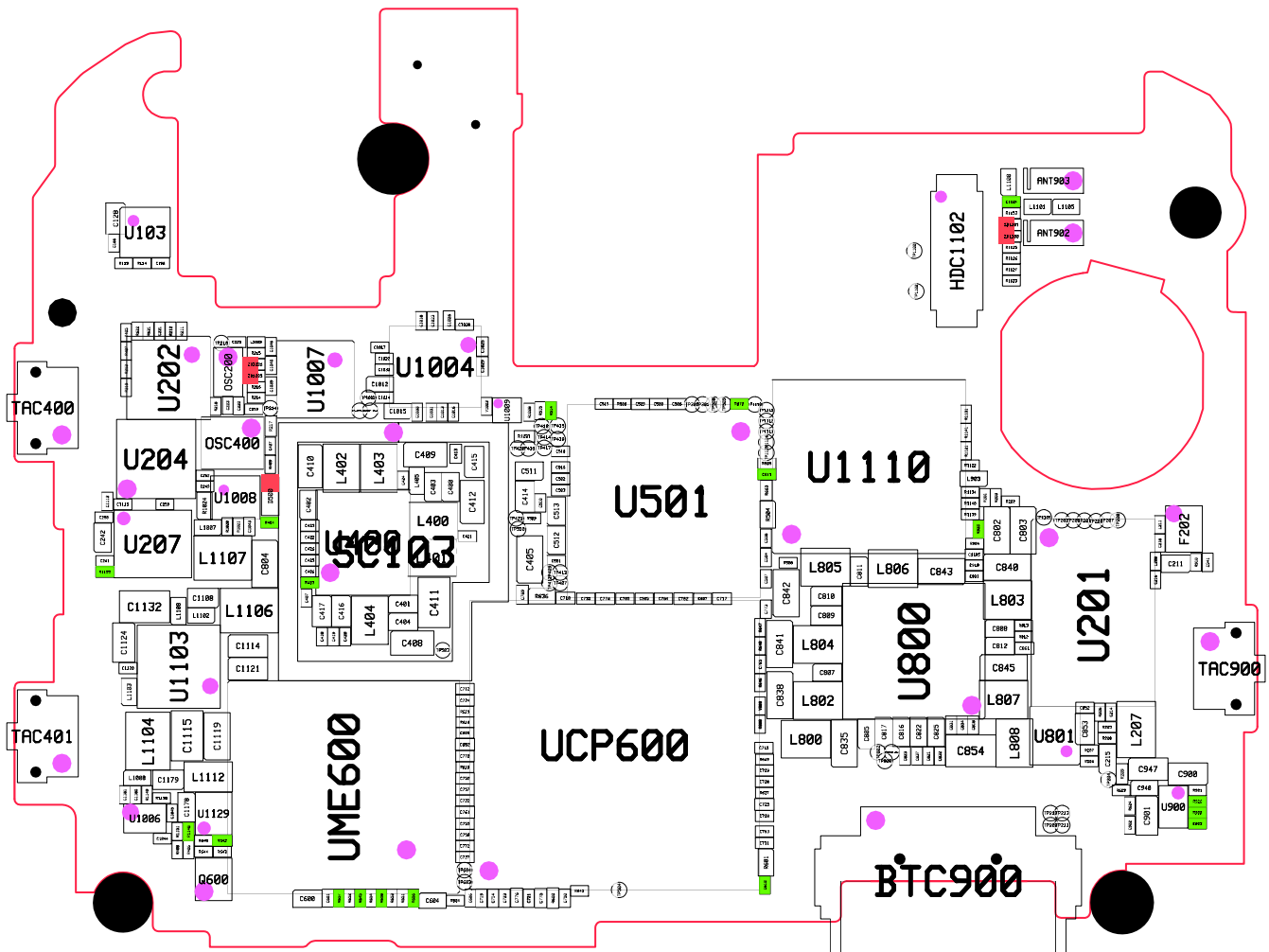

8-2-3. Sub PCB Top

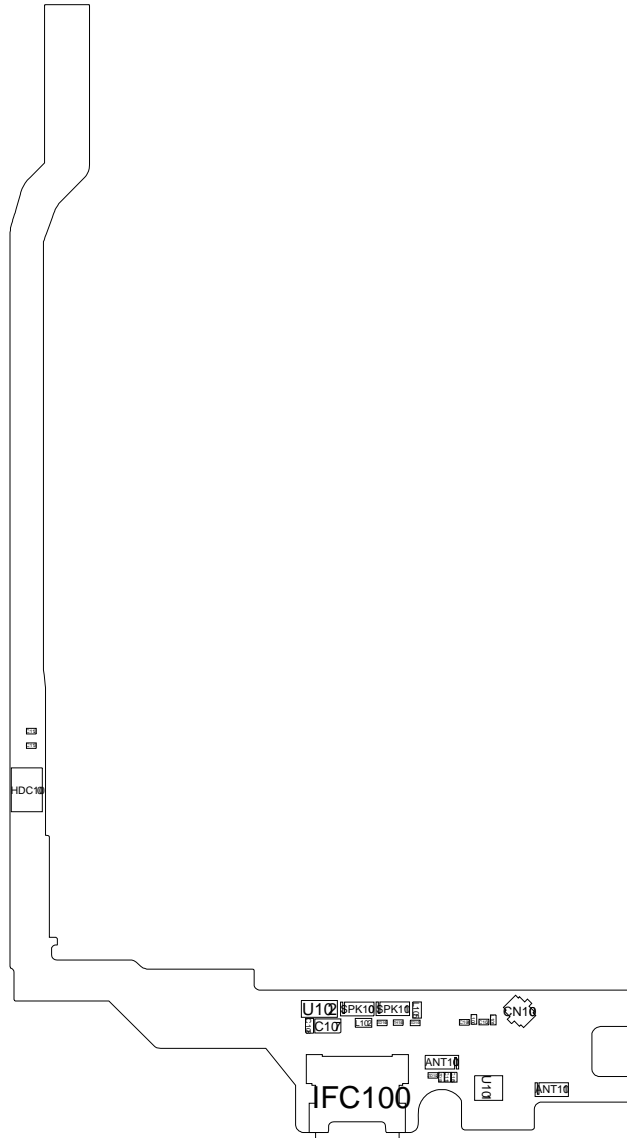

8-2-4. Sub PCB Bottom

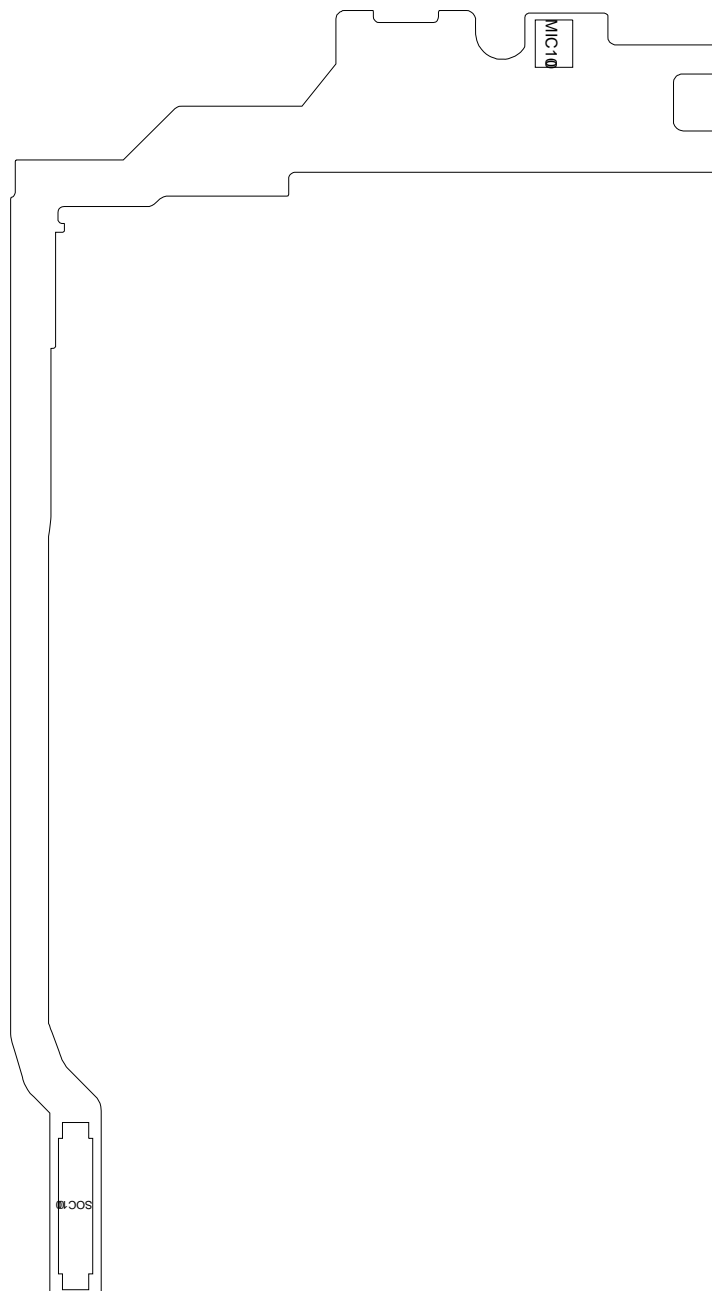

8-3. Flow Chart of Troubleshooting

Equipments

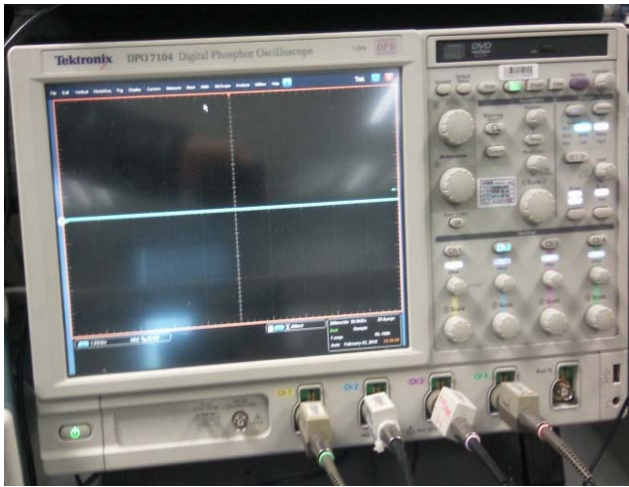

↑ Oscilloscope



↑ Digital Multimeter



↑ Power Supply



↑ + driver, ESD Safe Tweezer

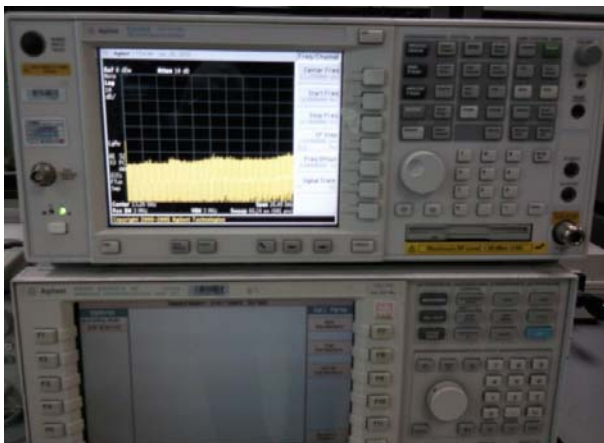

↑ 8960 & Spectrum Analyzer



↑ Soldering iron

8-3-1. Power On

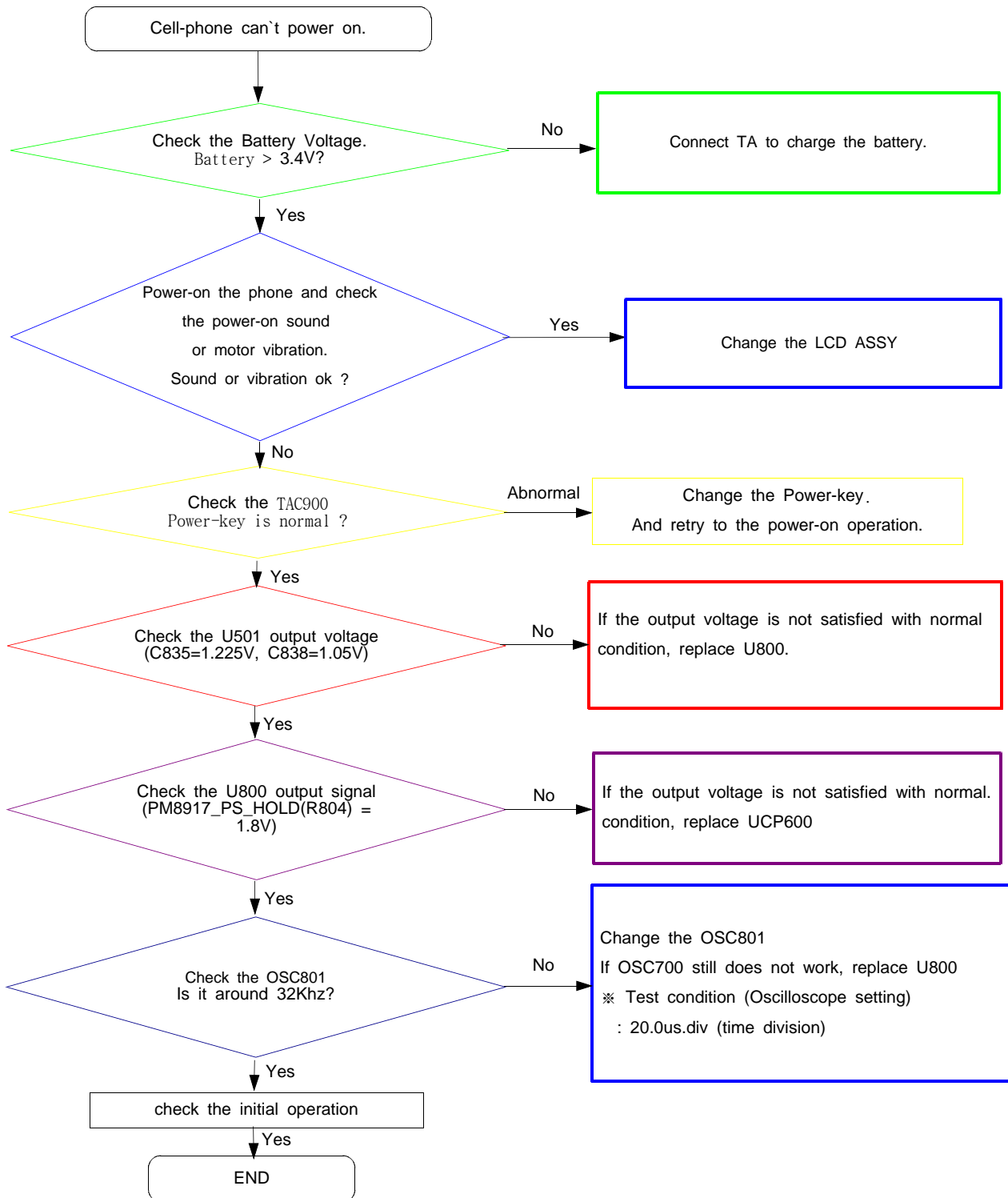

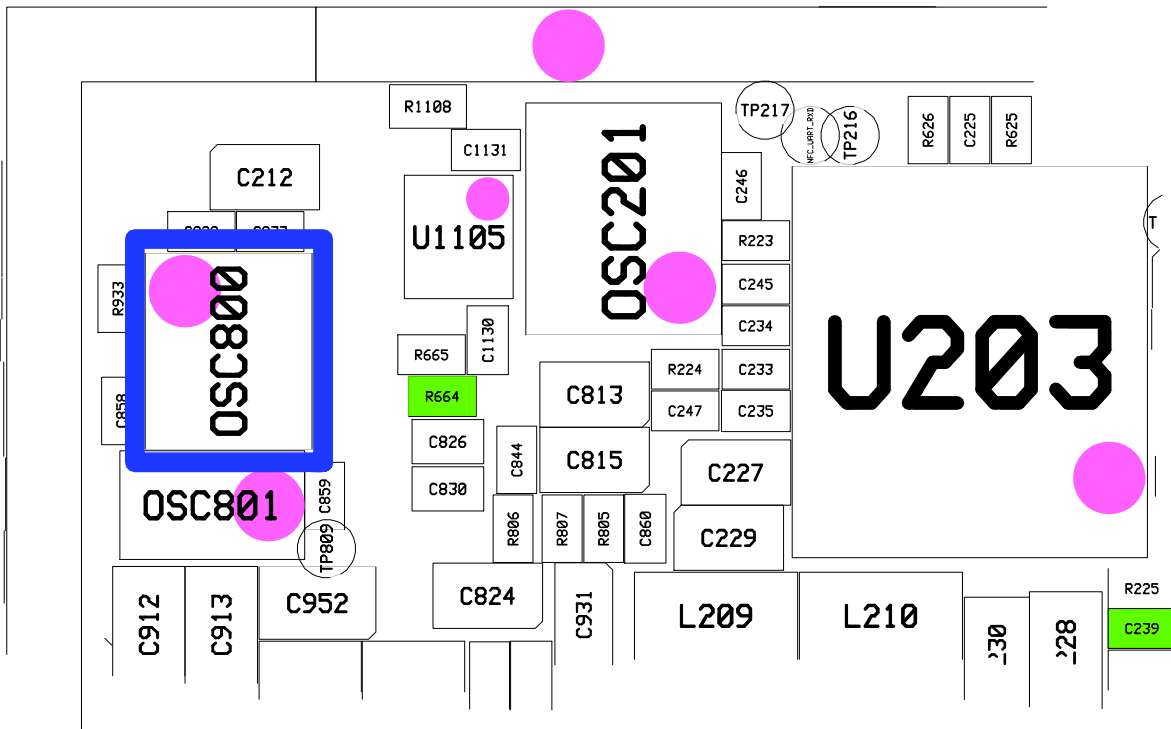
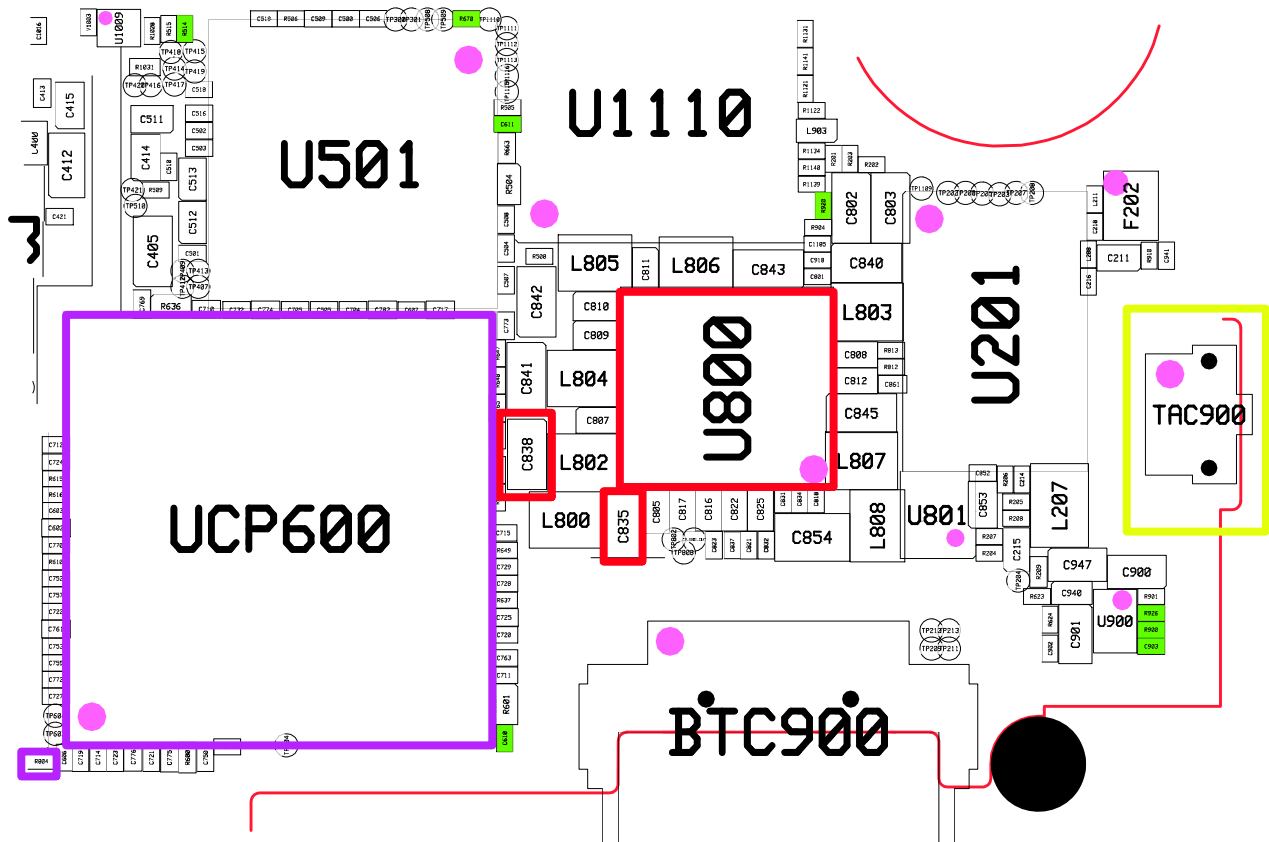

8-3-2. Initial

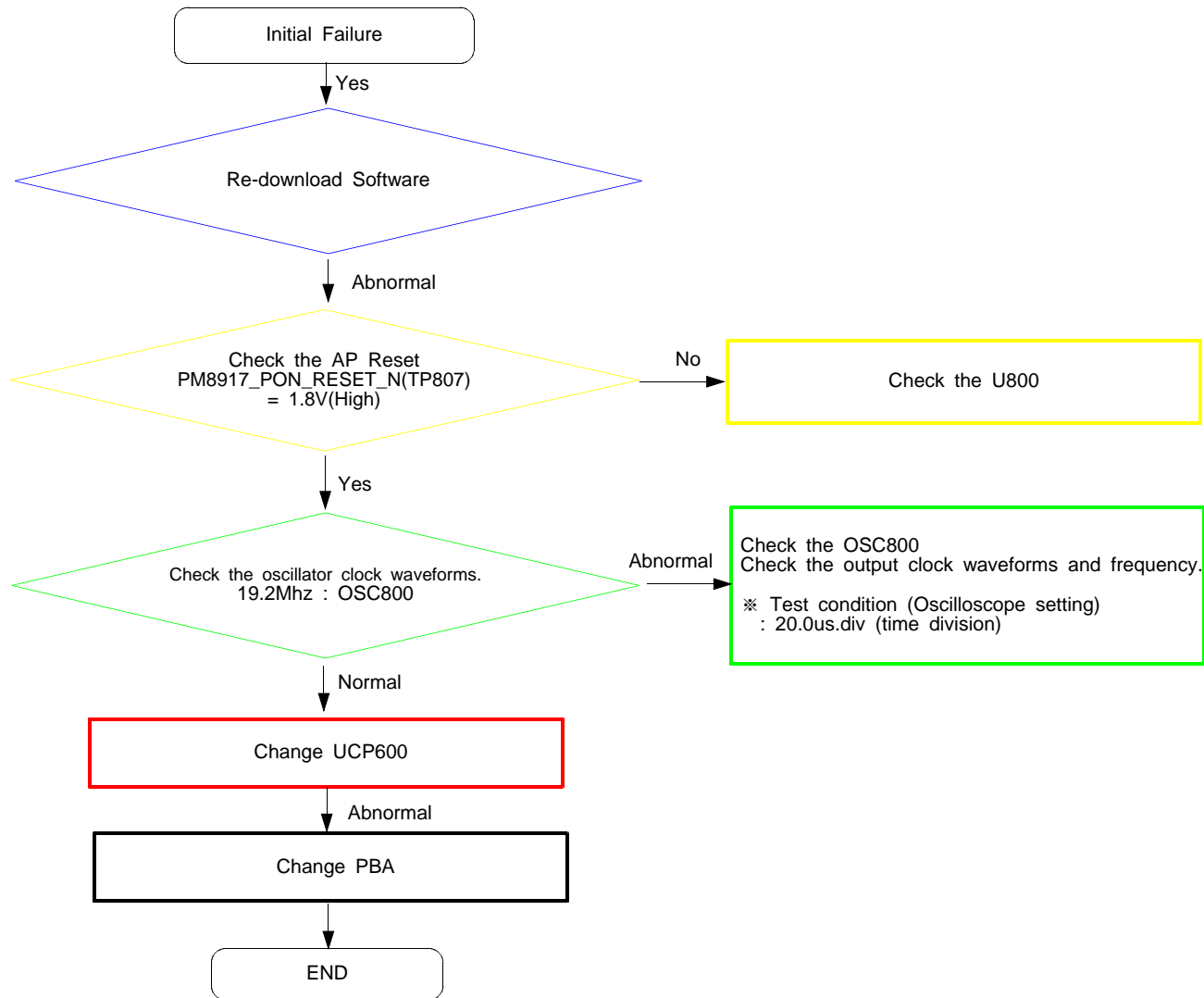

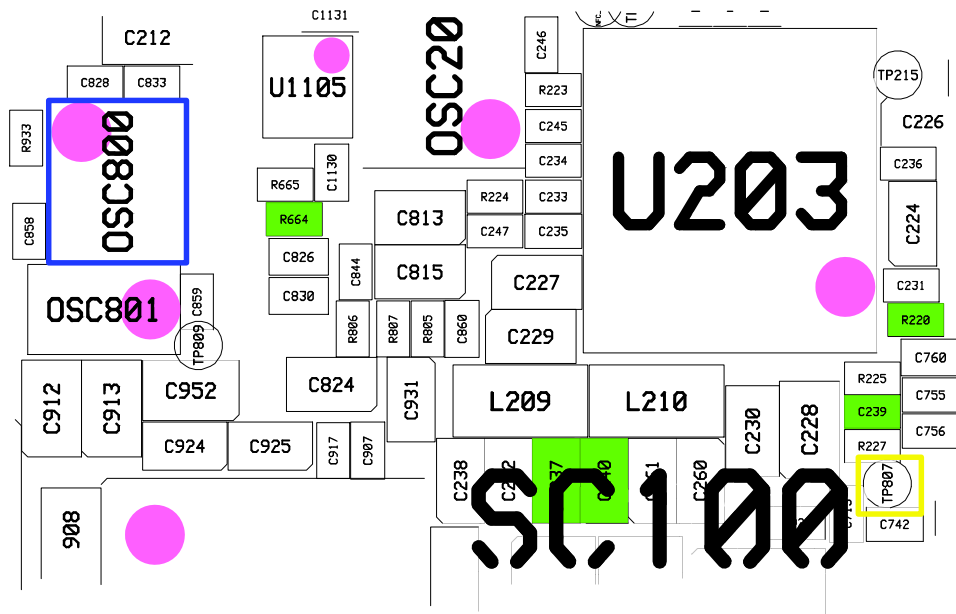
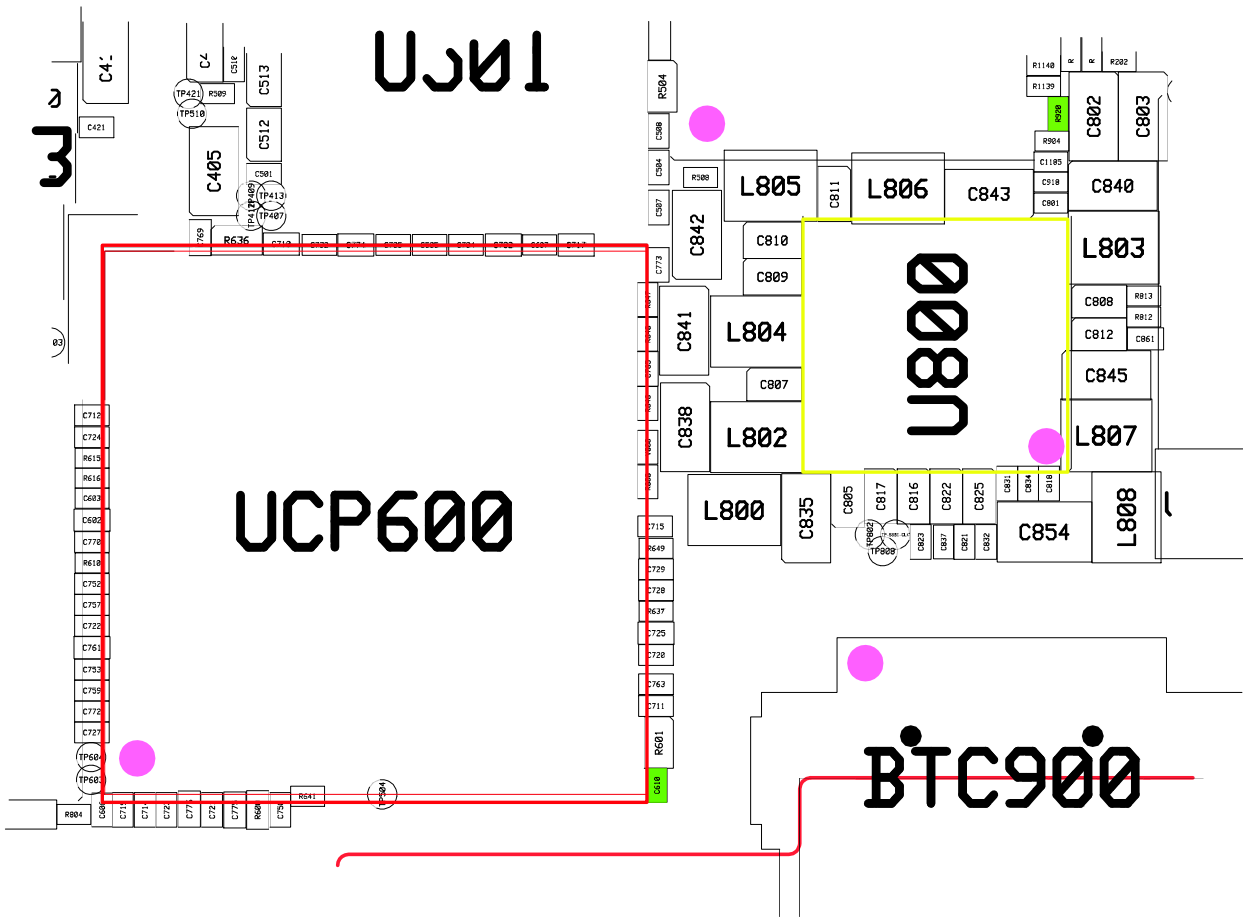

8-3-3. No Service

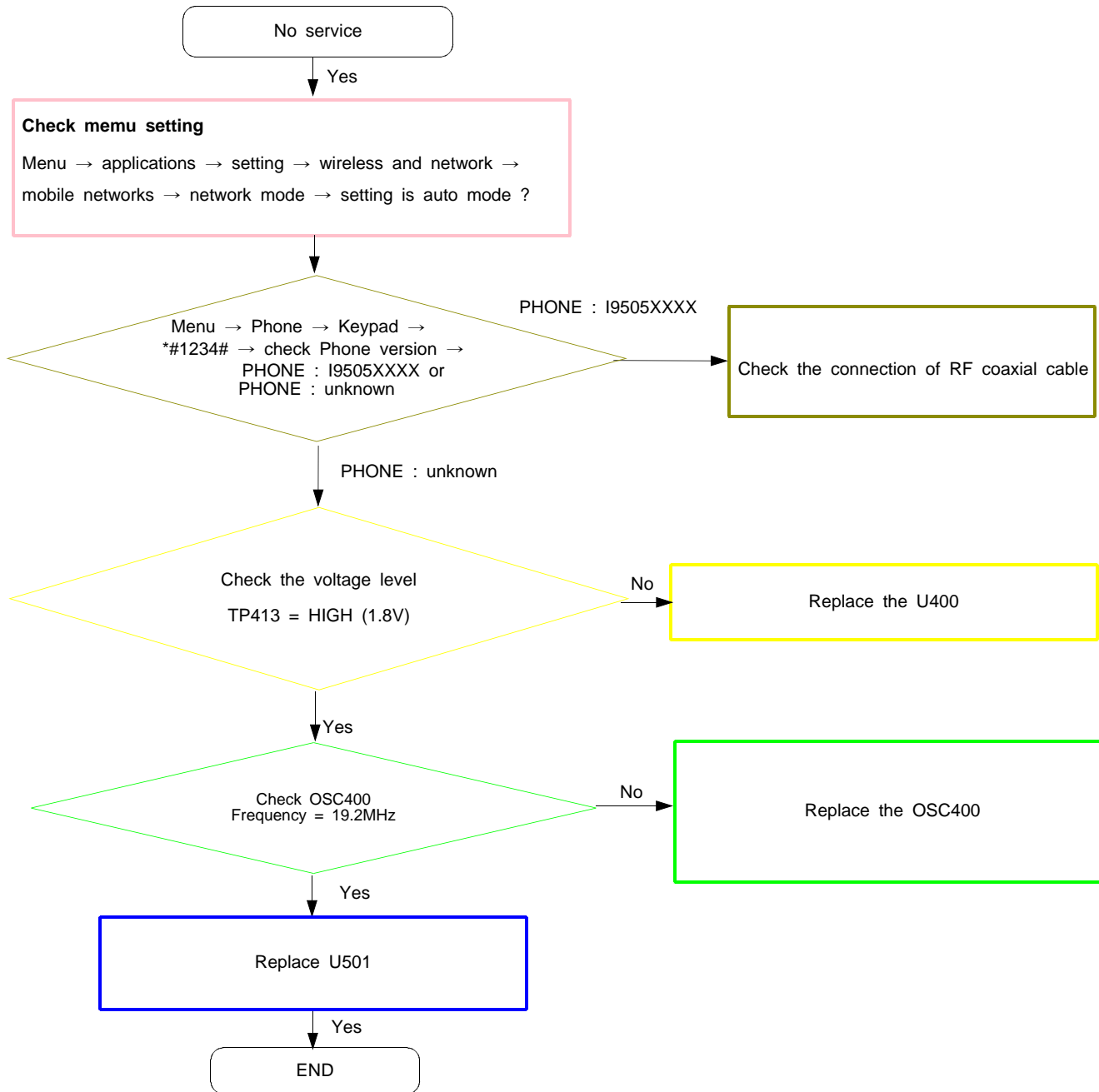

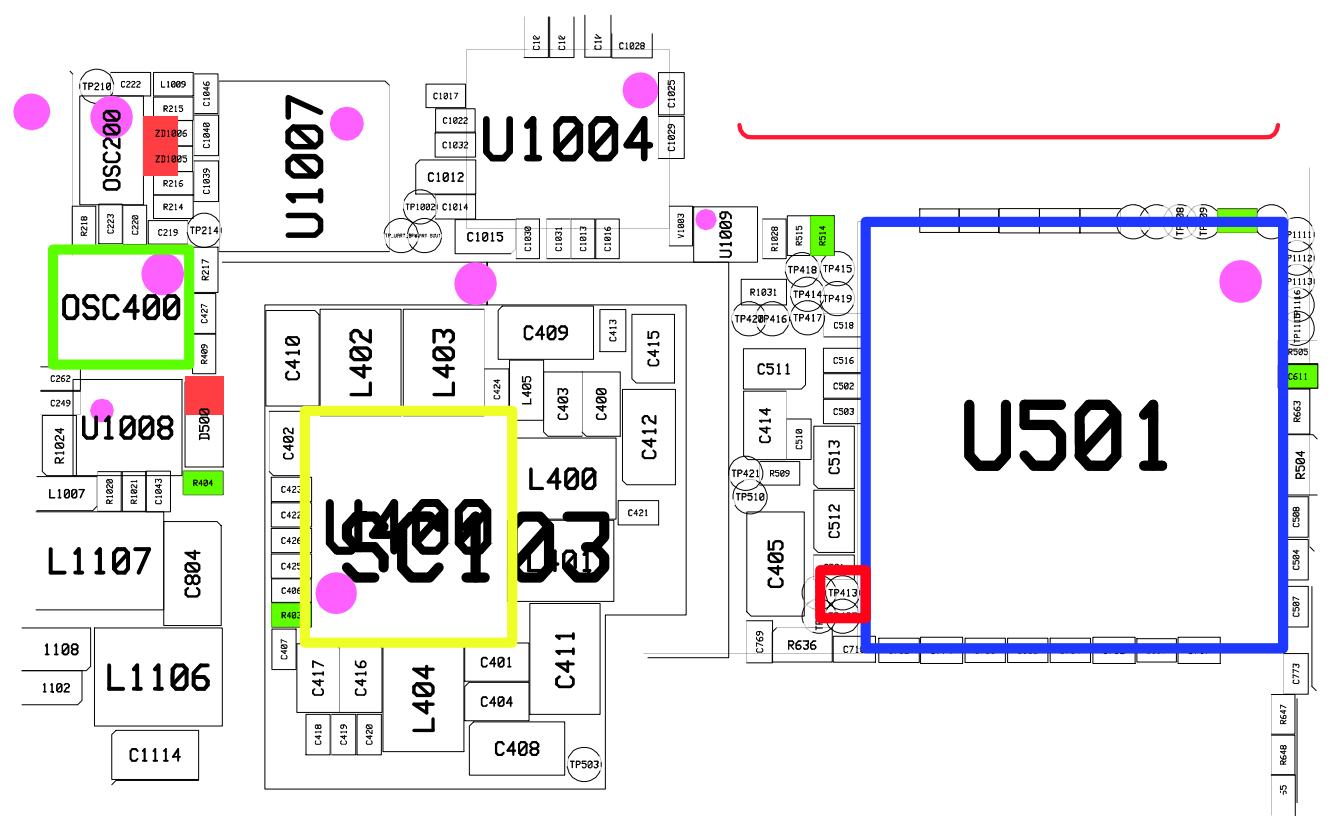

8-3-4. Sim Part

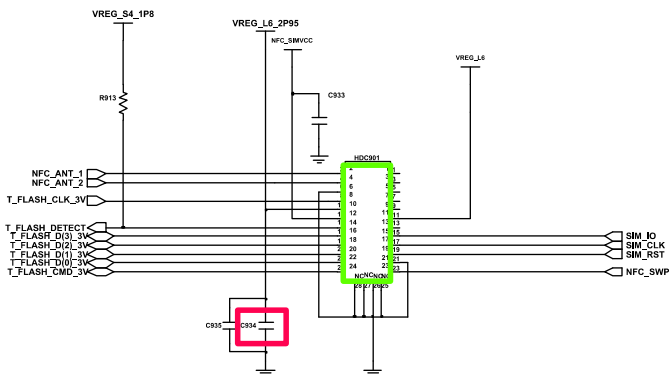
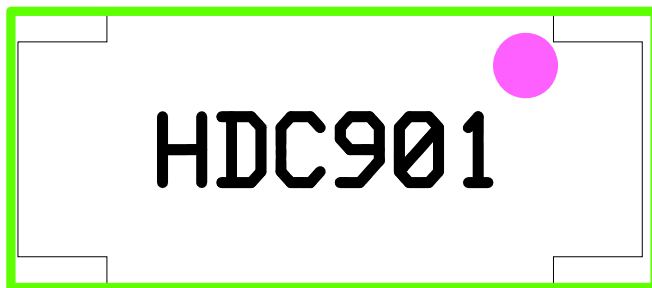
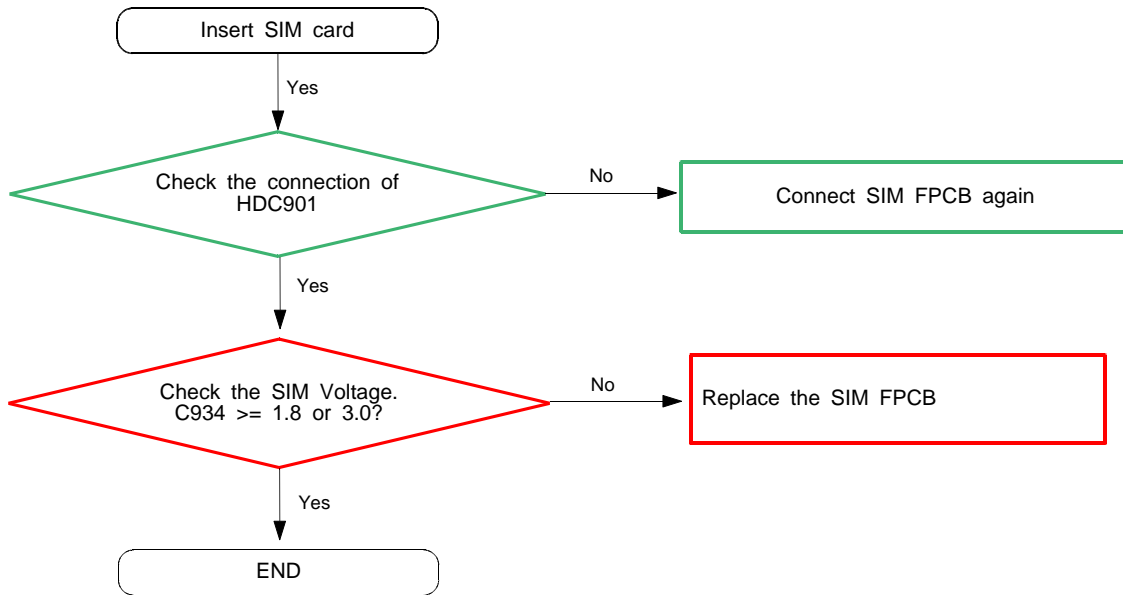

8-3-5. Charging Part

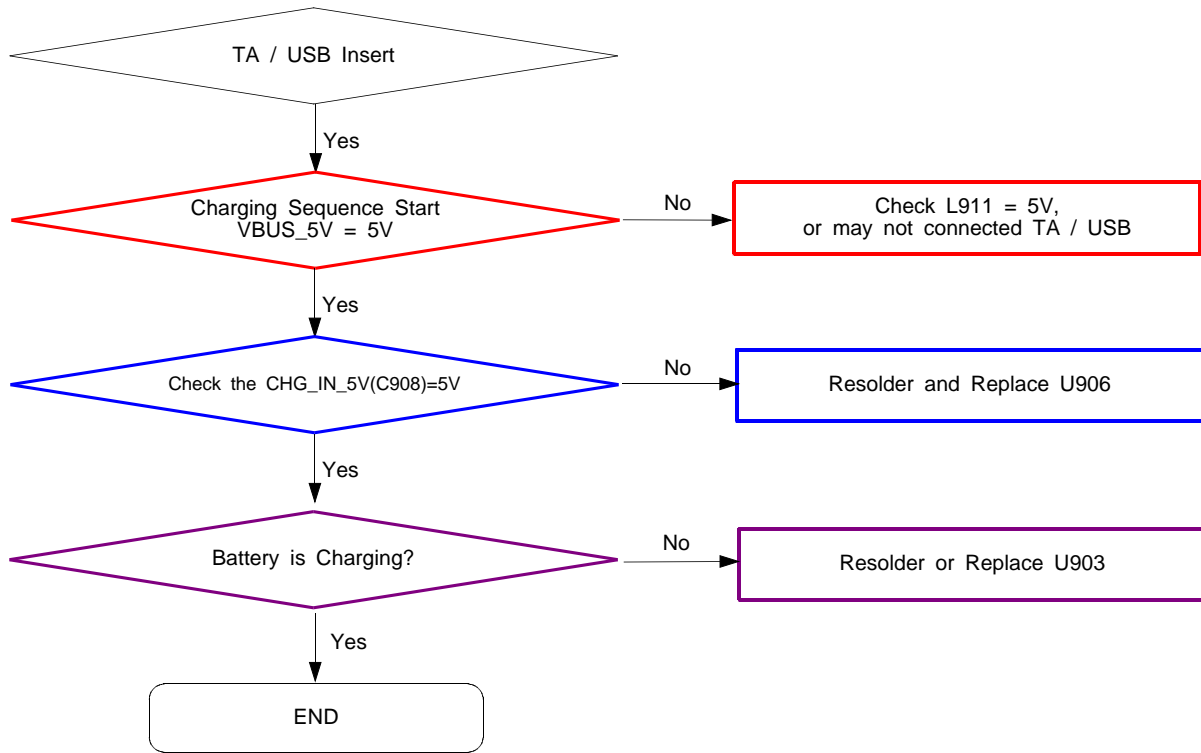

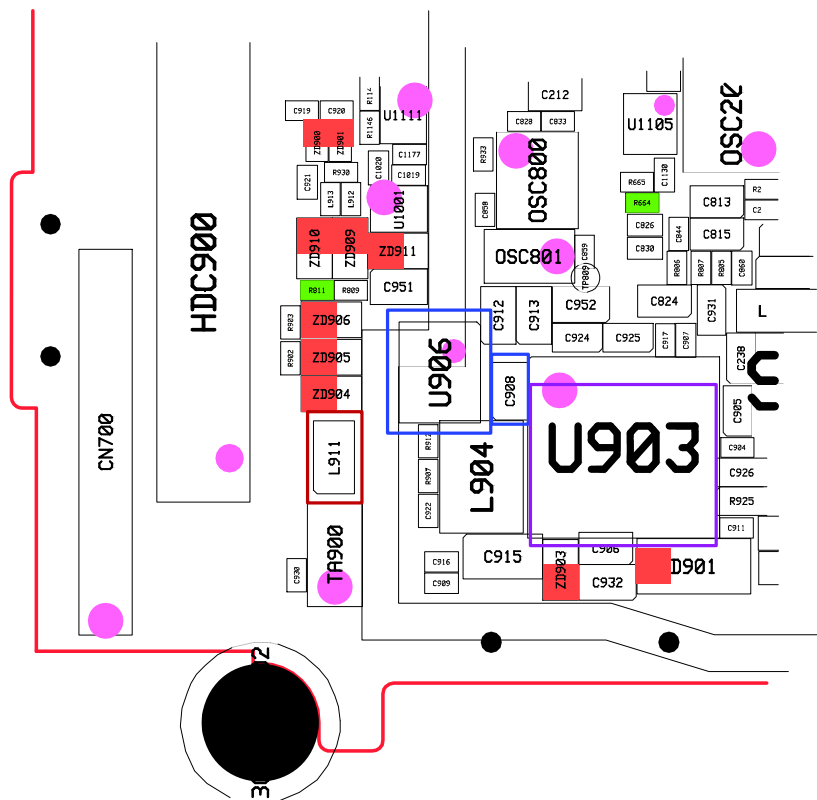
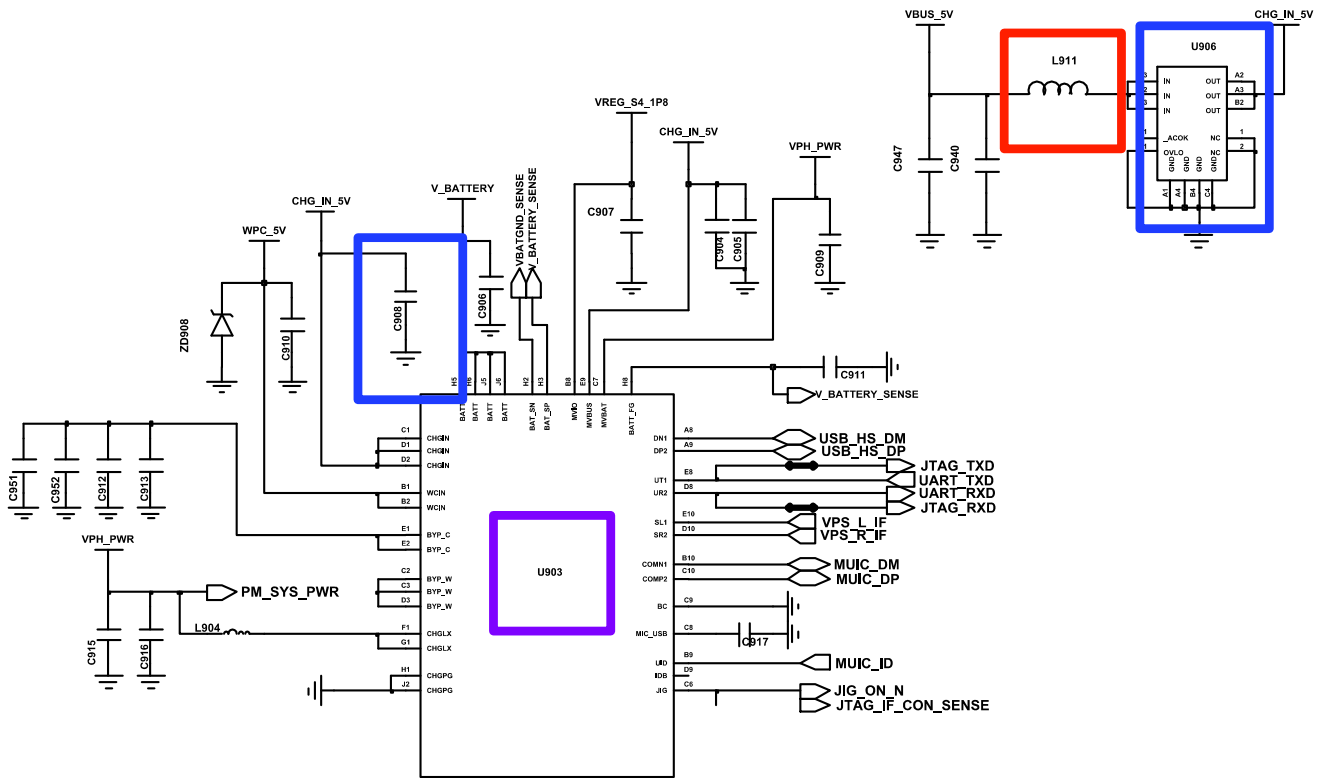

8-3-6. OTG

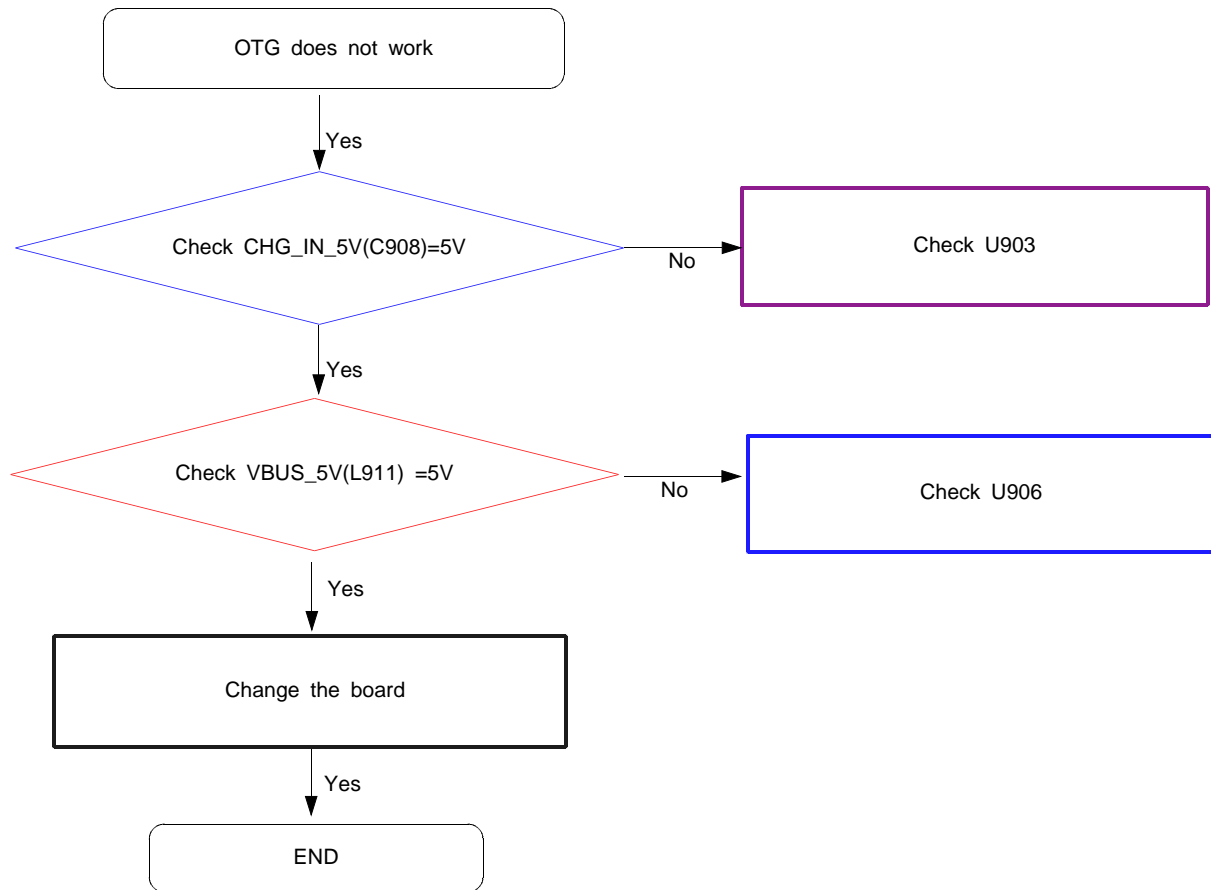

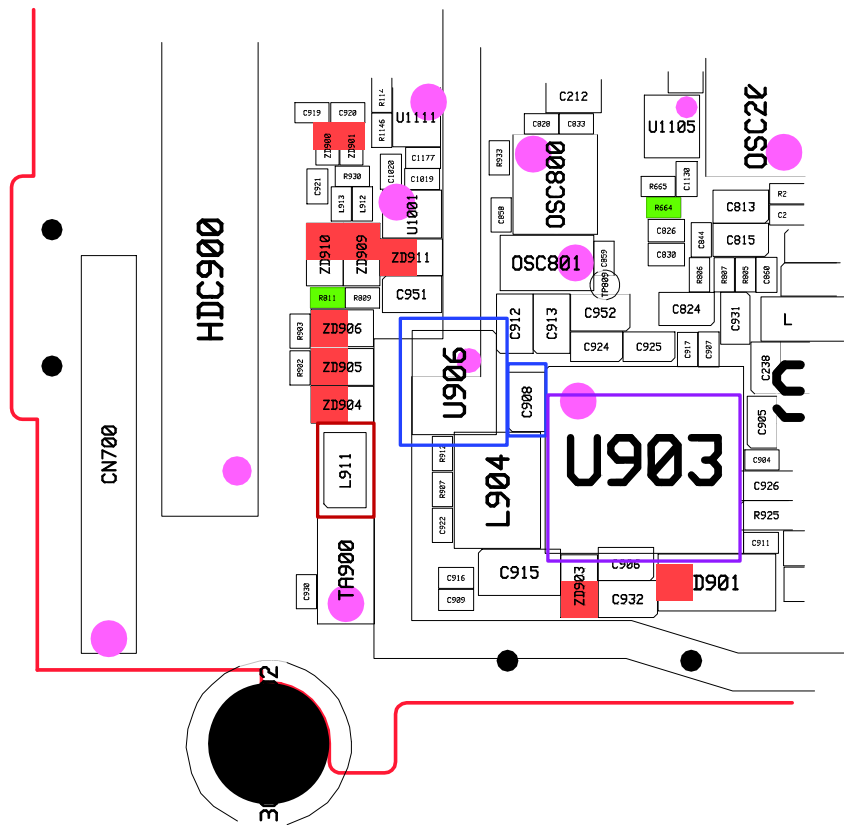
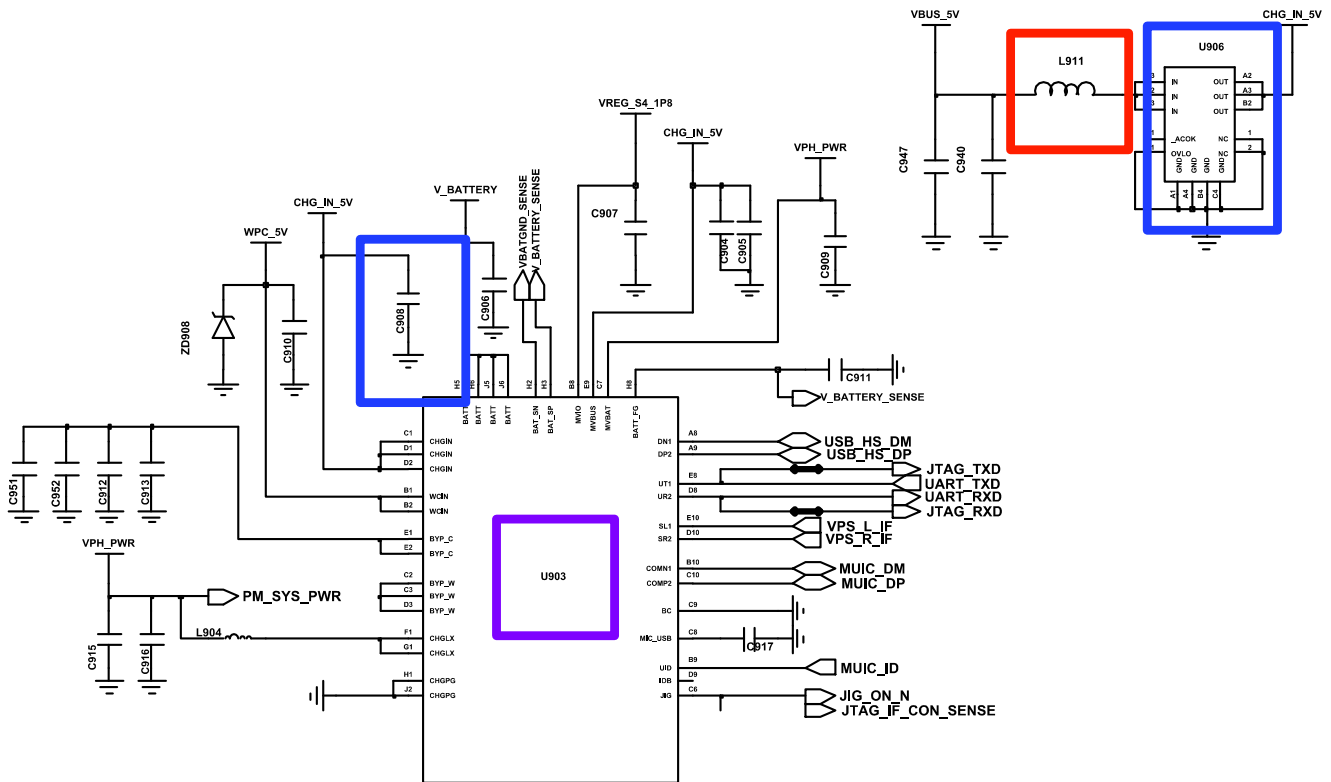

8-3-7. Sensor

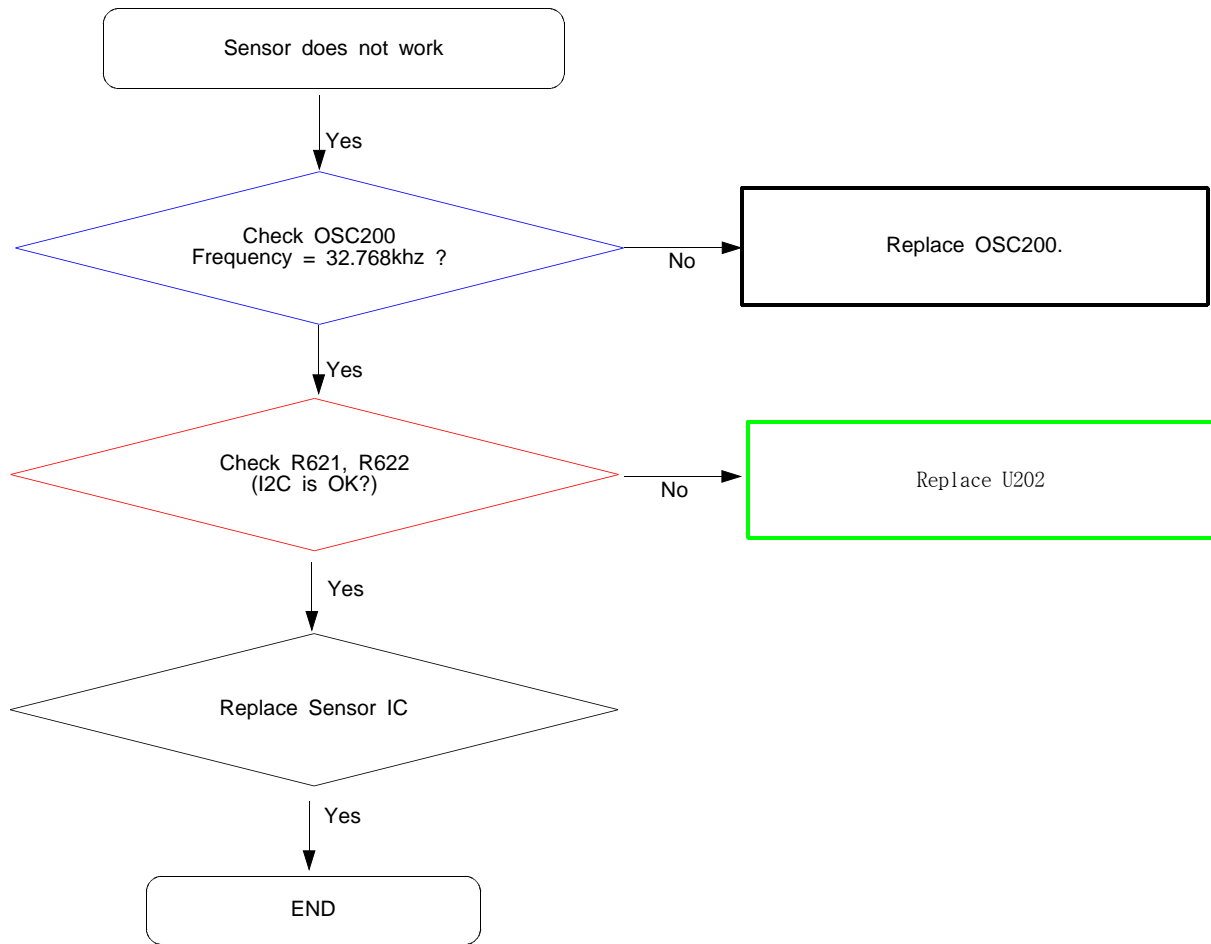

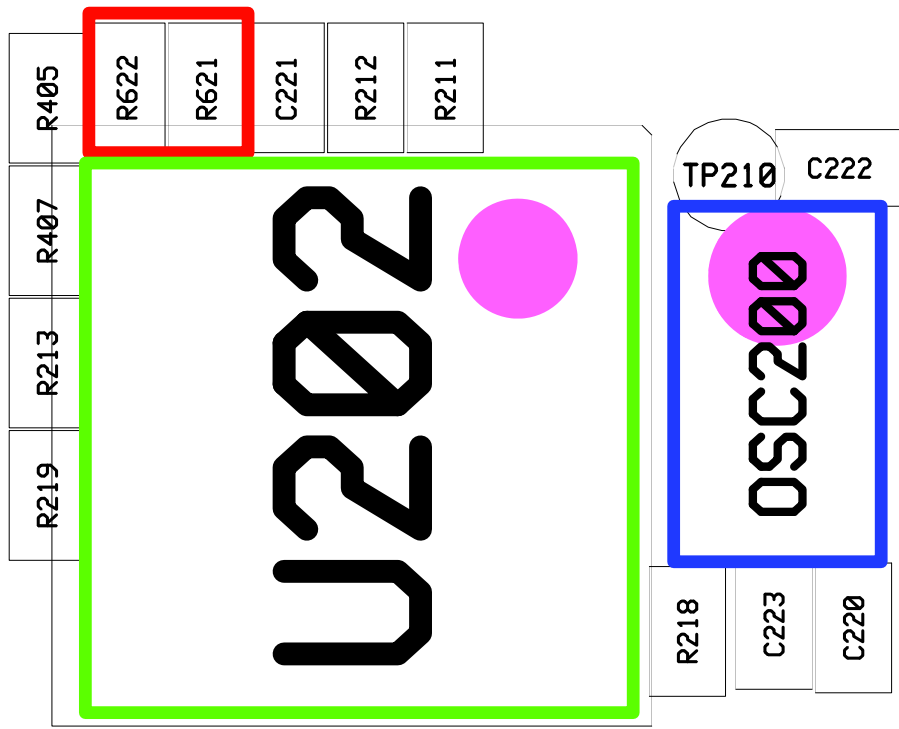
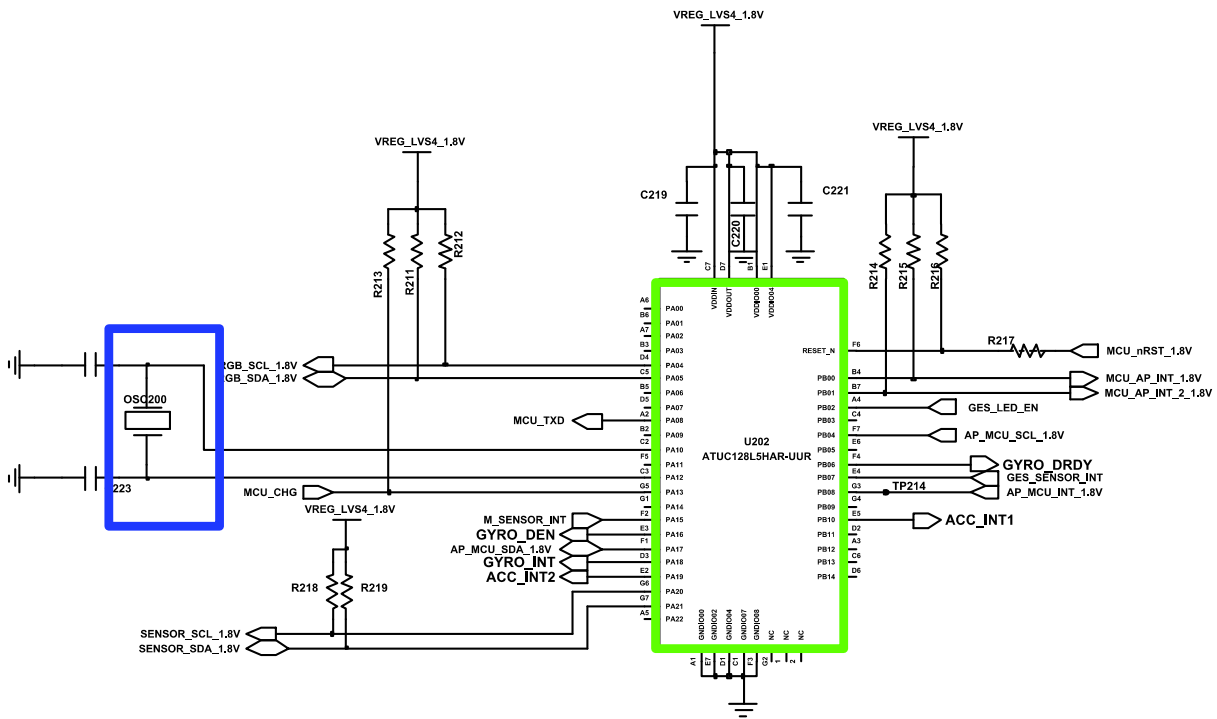

※ **CAUTION**

Temperature/Humidity sensor should not be directly exposed to the heat-gun when you replace USB connector, because excessive heat can cause abnormal operation of the sensor. The temperature that Temperature/Humidity sensor sees should not exceed 260°C. Use proper heat-shielding material to protect Temperature/Humidity sensor.

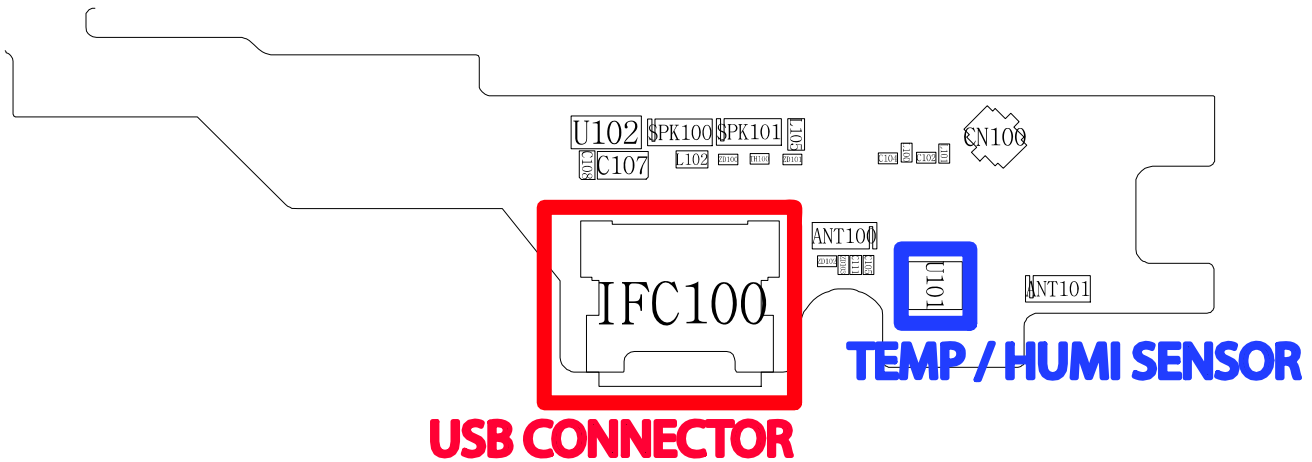

※ **Temp/Humi Sensor After Repair**

- 1) Keypad : press *#0*#
- 2) Select "Sensor"
- 3) Select "Temp-Humid"
- 4) Read the COMP data (ignore the RAW data)

TEMP - HUMID TEST		
	RAW	COMP
TEMP	27.21	24.354591
HUMID	26.89	35.669205

8-3-8-1 Microphone Part - Main MIC

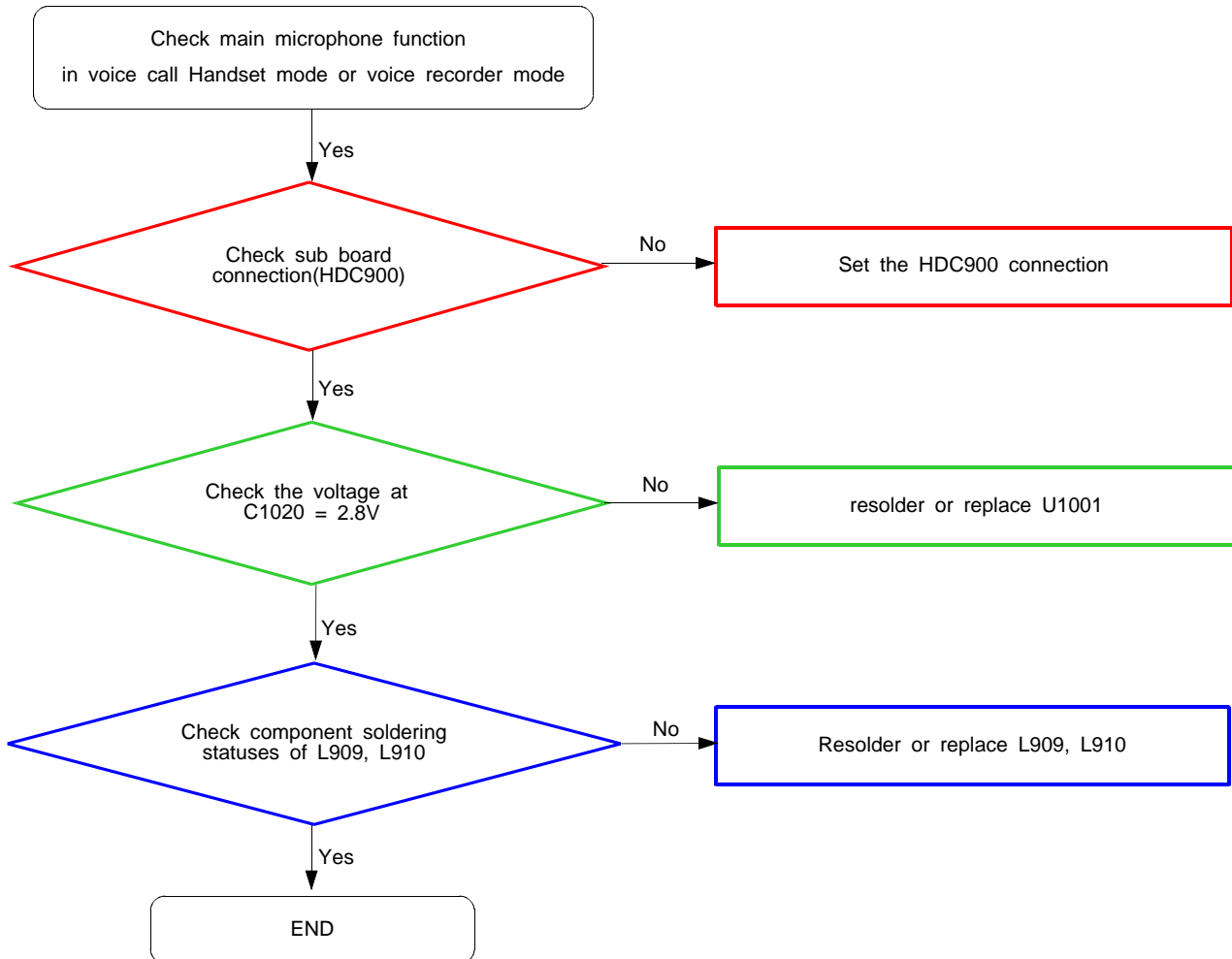

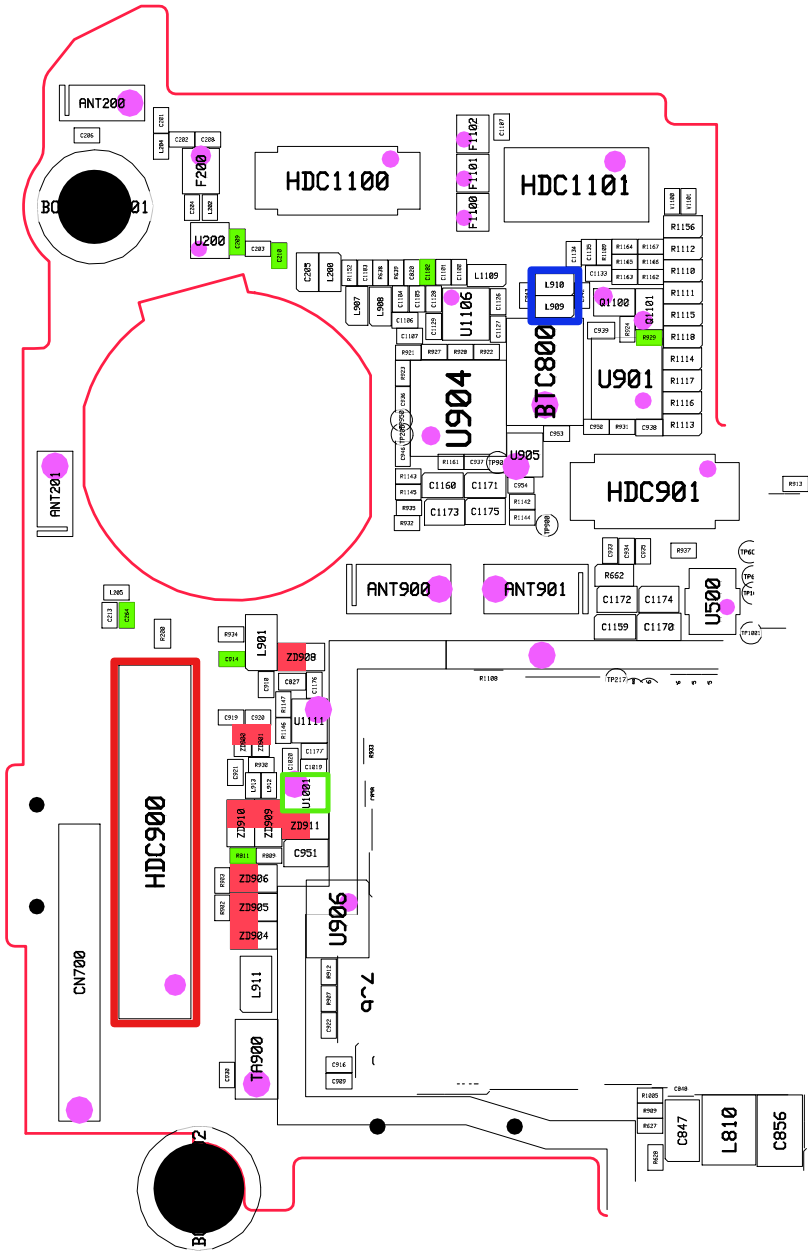
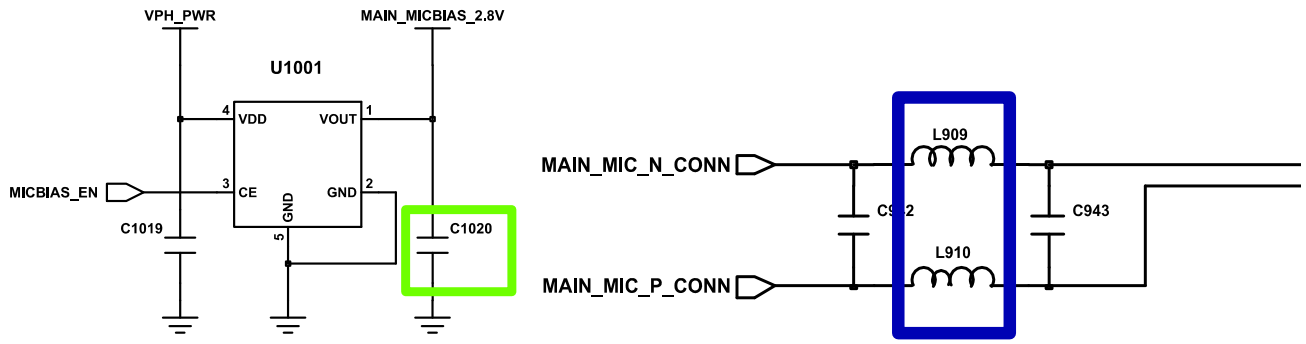

8-3-8-2. Microphone Part - Sub(2nd) MIC

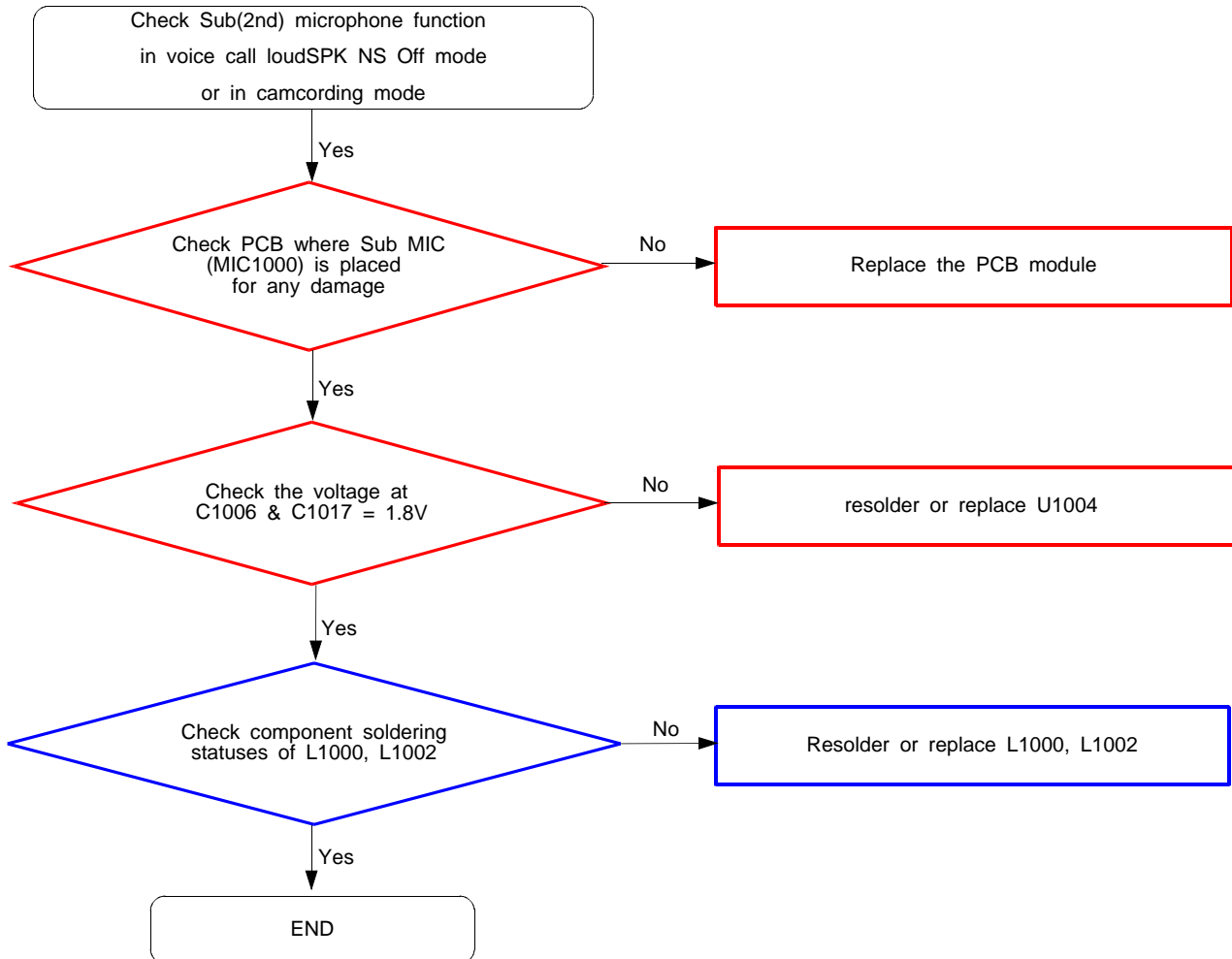

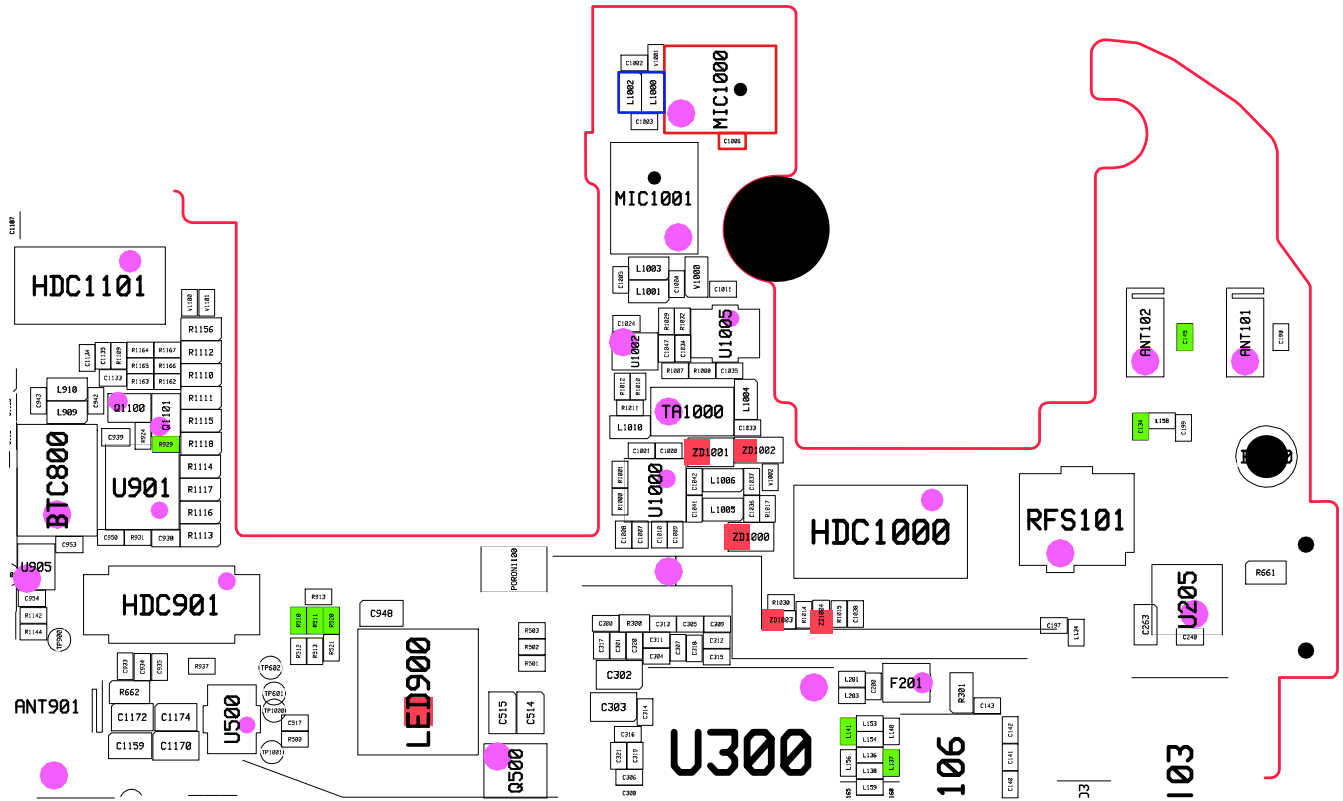
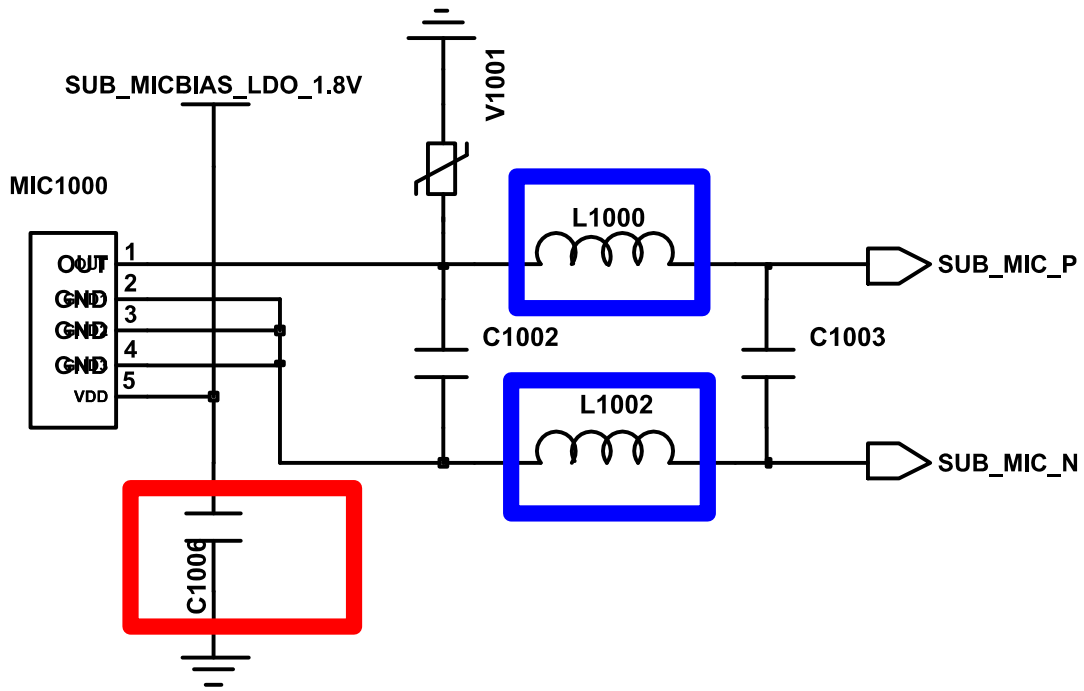

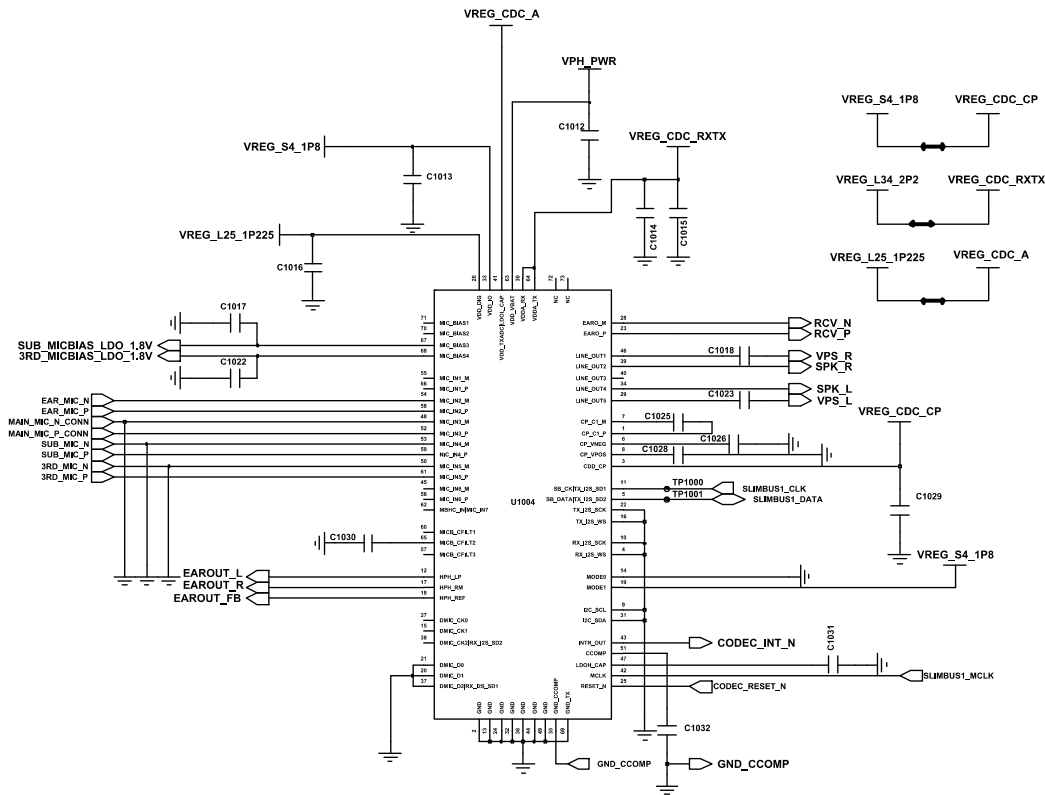

AUDIO CODEC

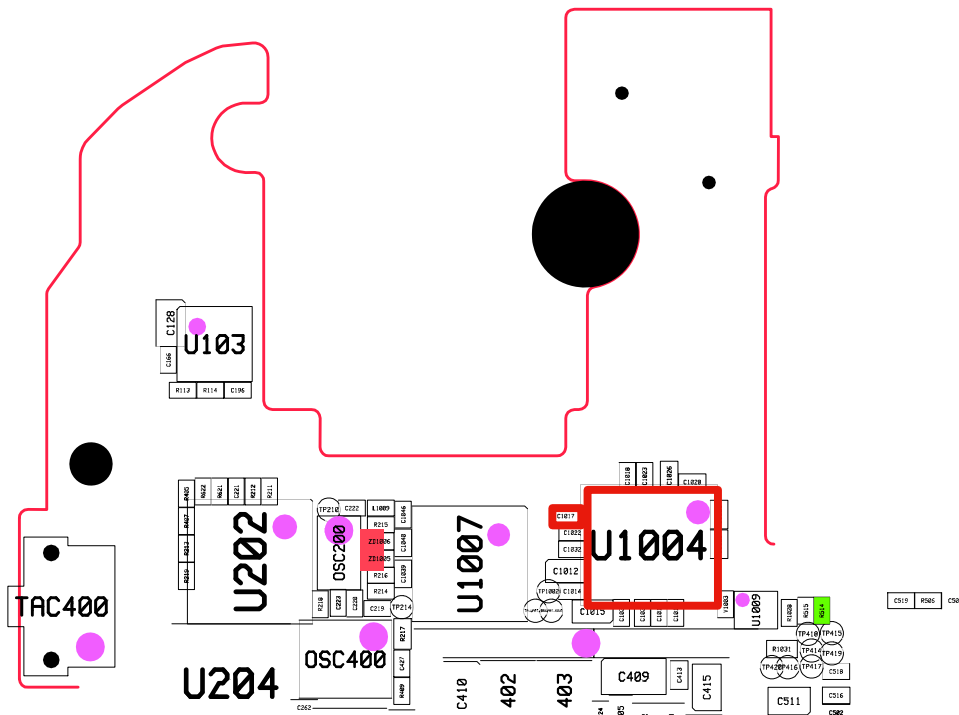

8-3-8-3. Microphone Part - 3rd MIC

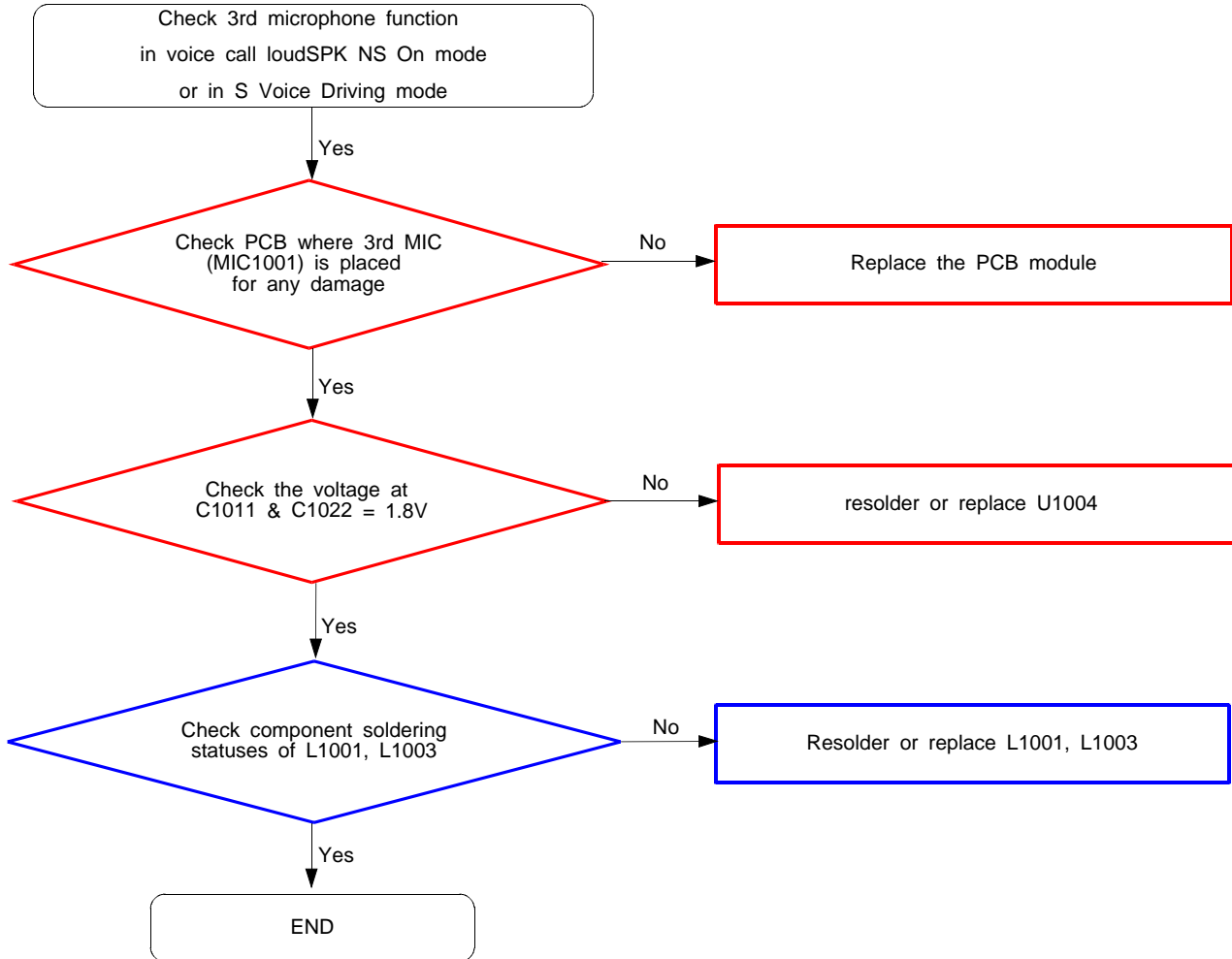

3RD_MICBIAS_LDO_1.8V

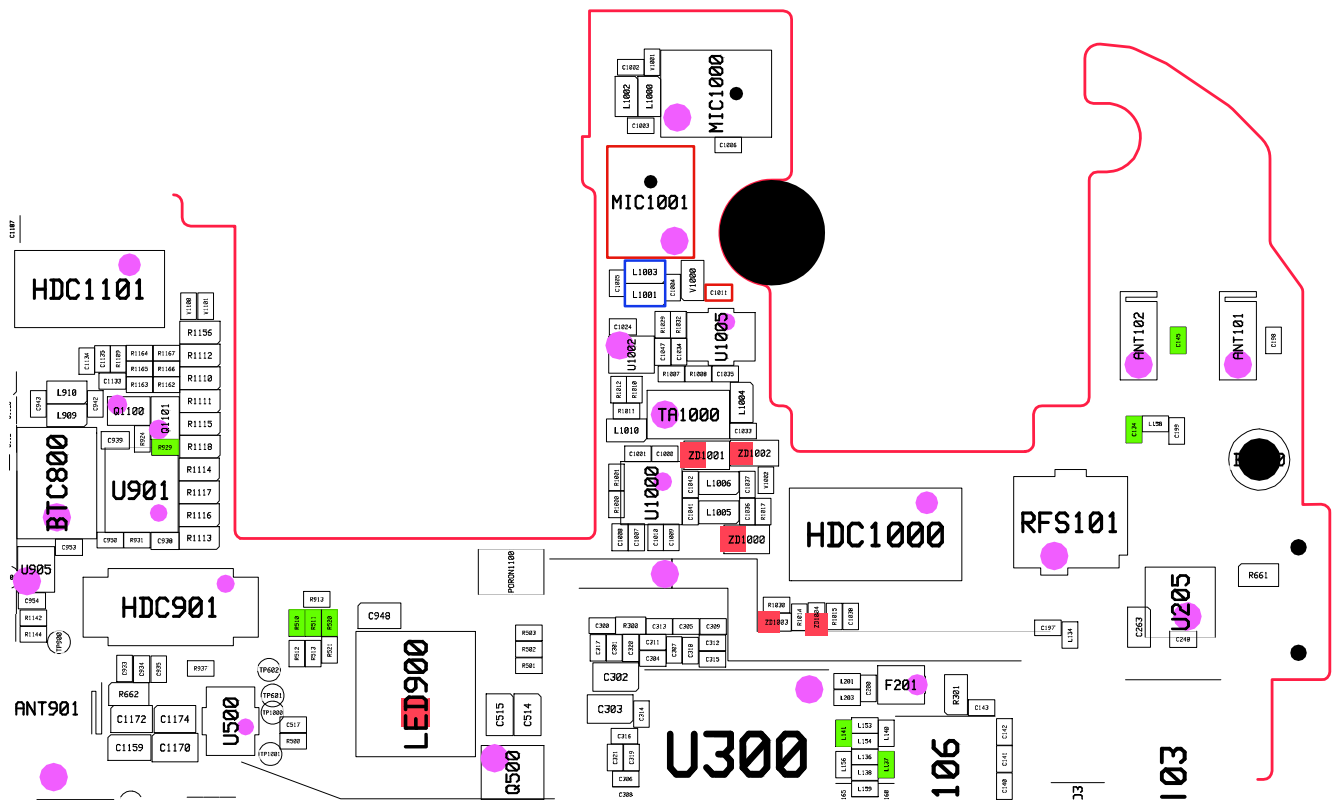
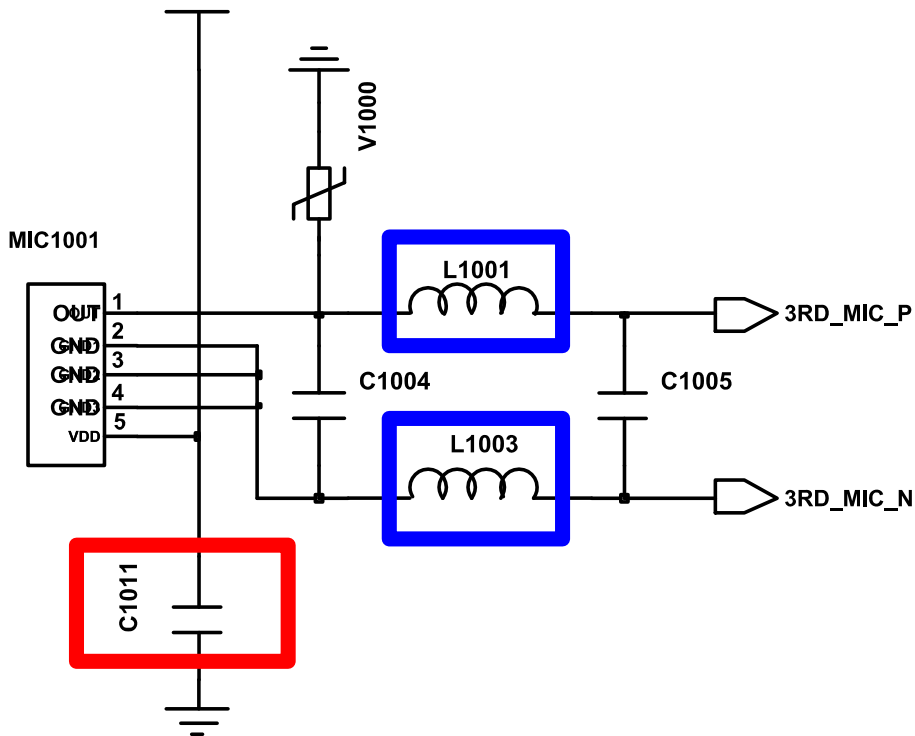

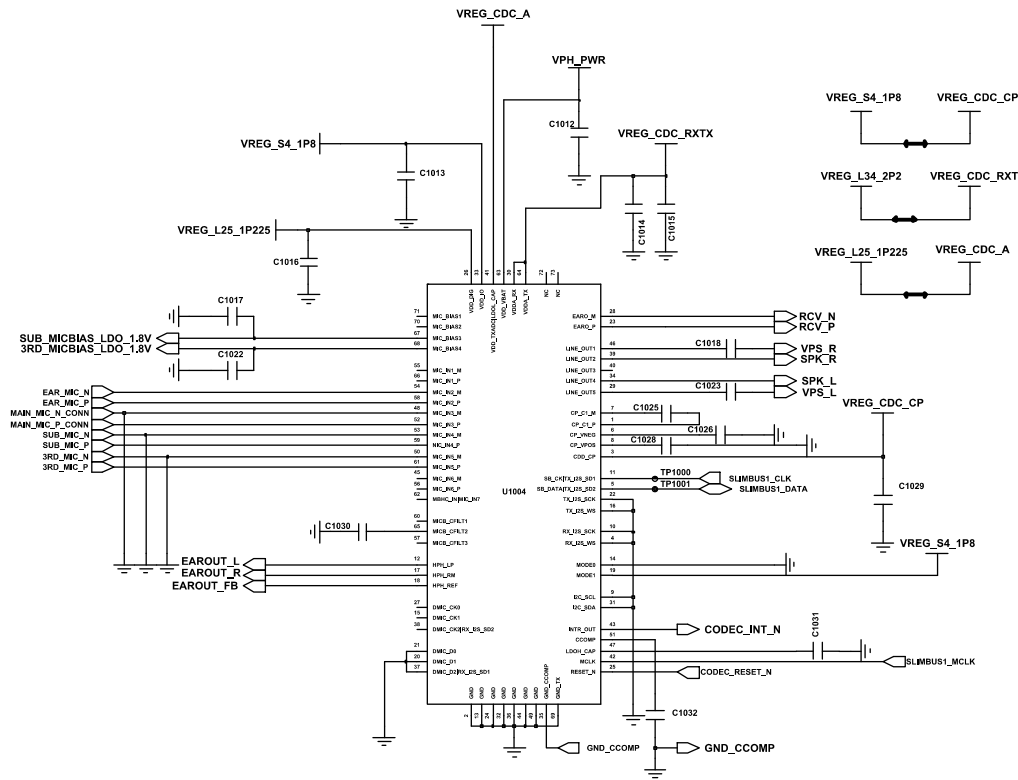

AUDIO CODEC

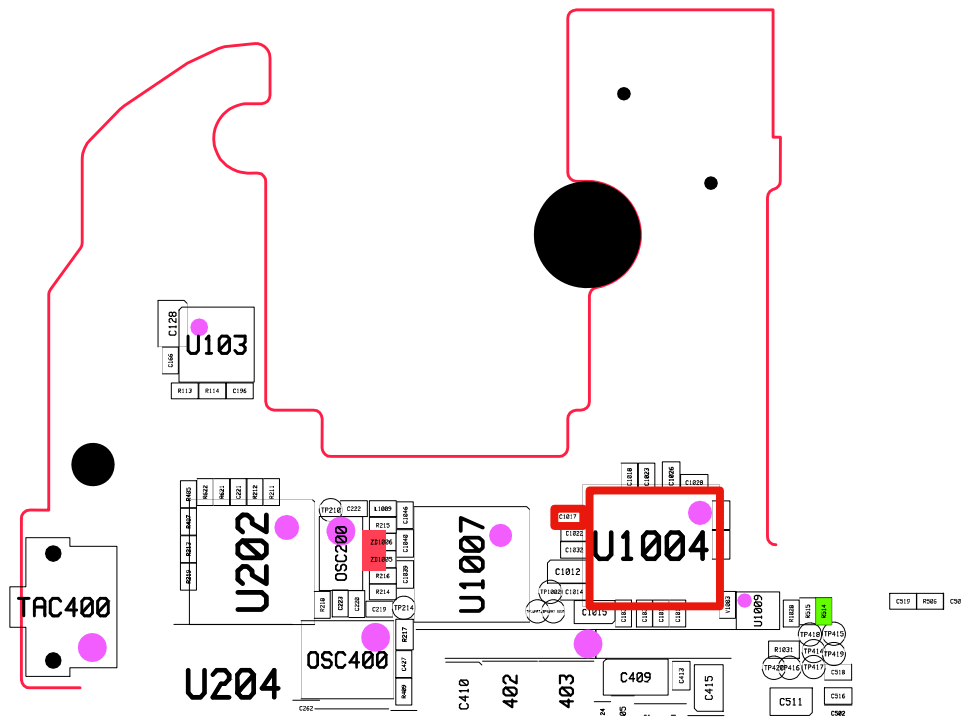

8-3-9. Speaker Part

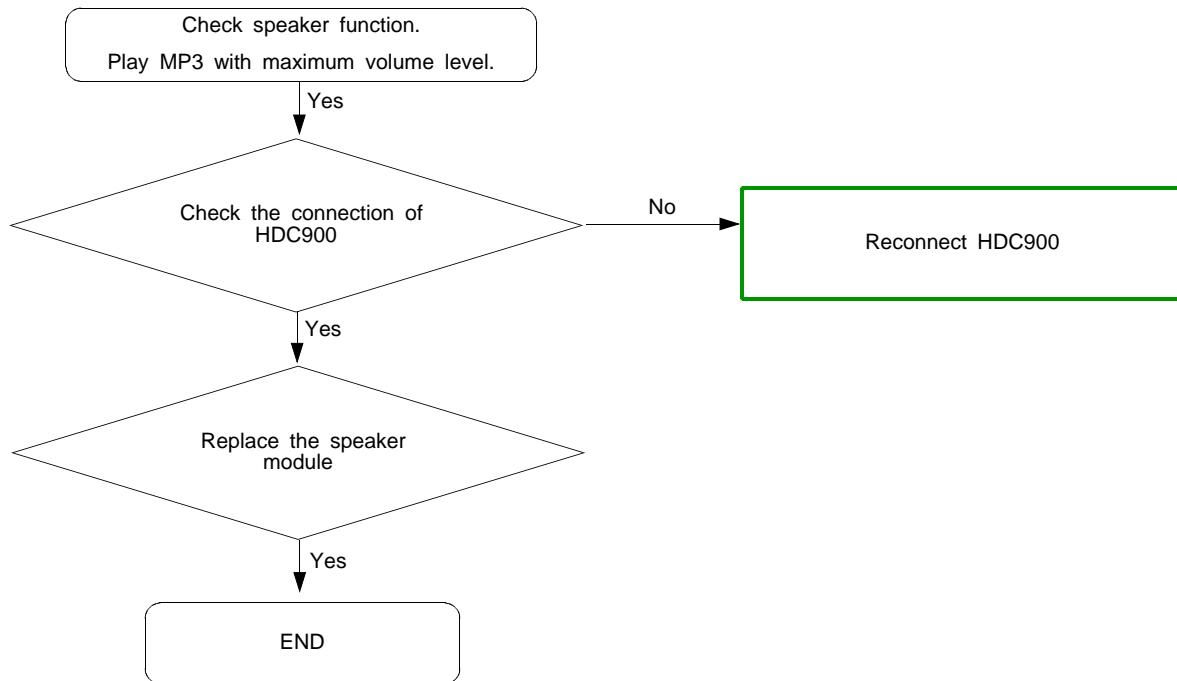

..

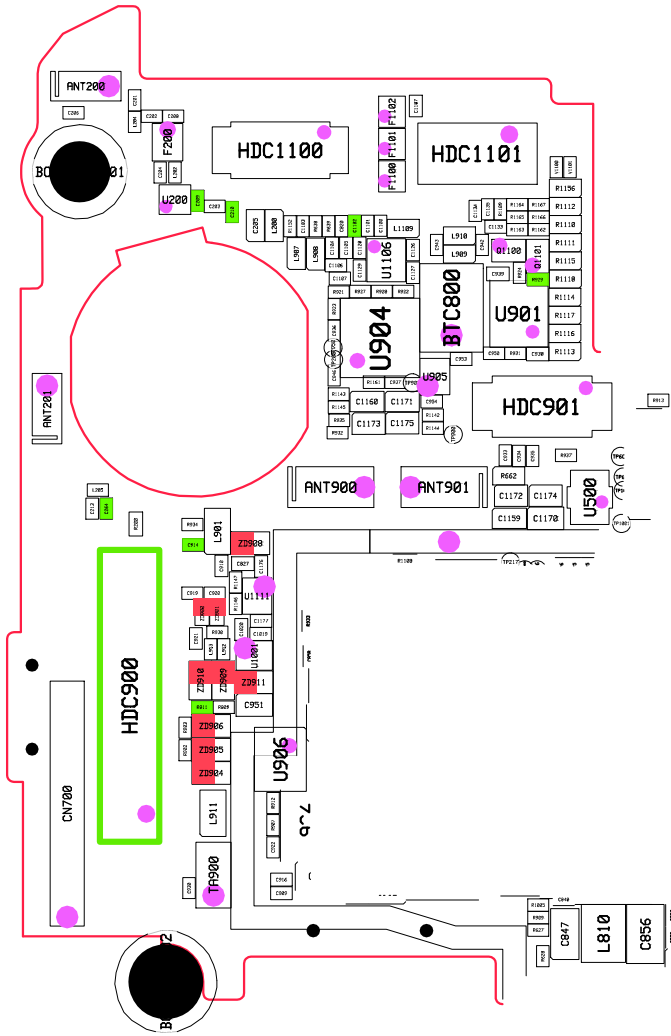
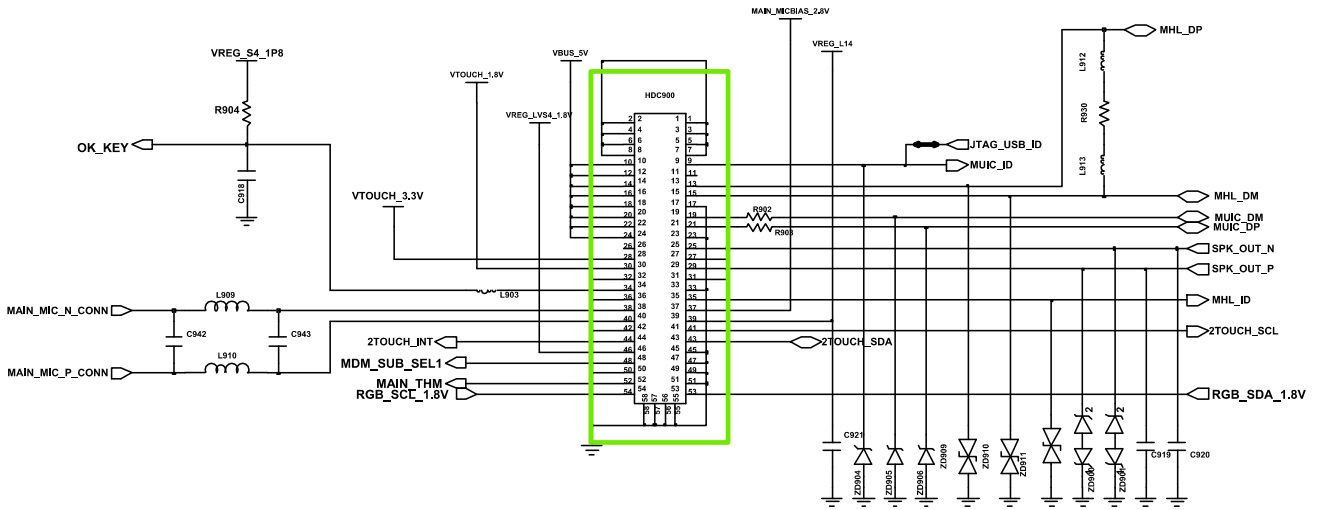

8-3-10. Receiver Part

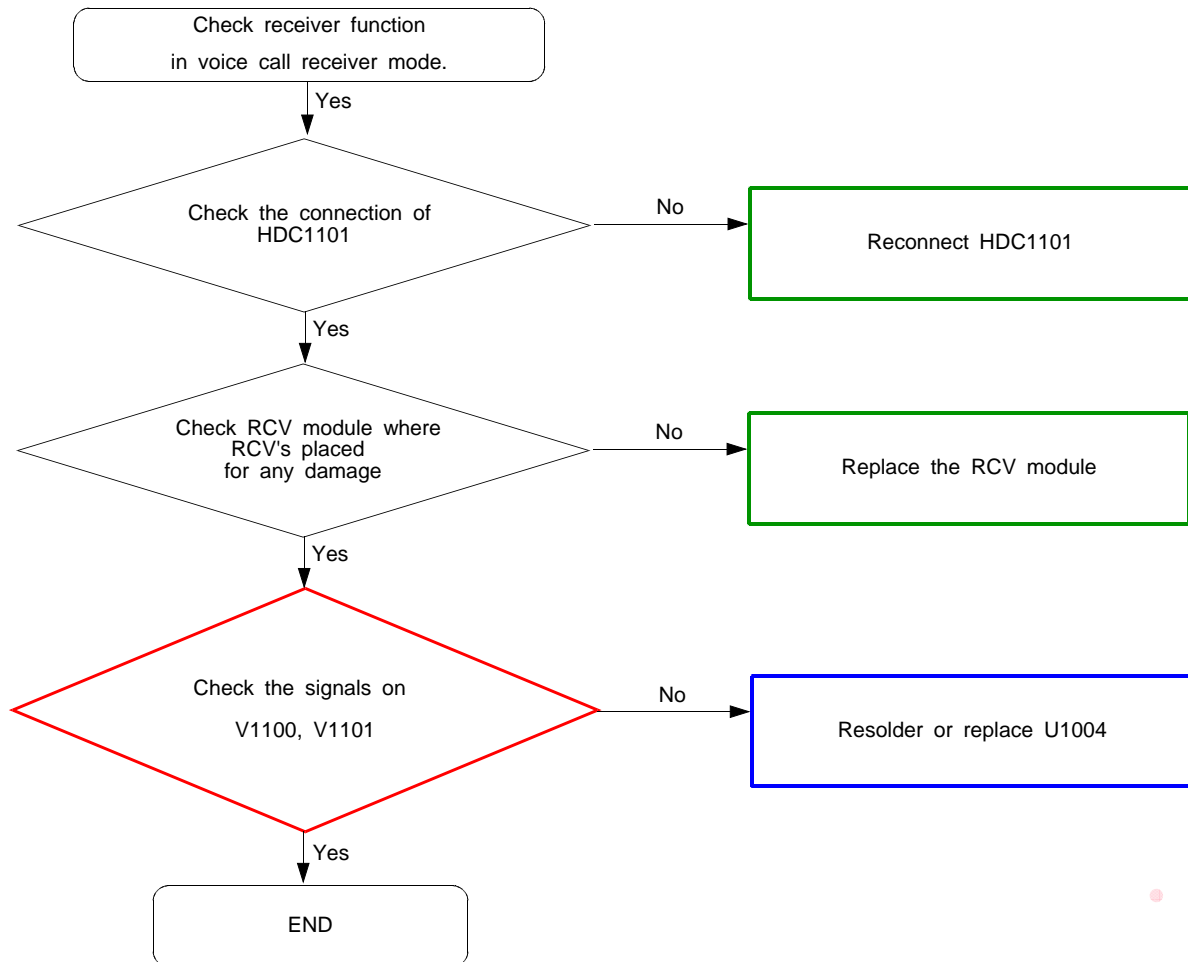

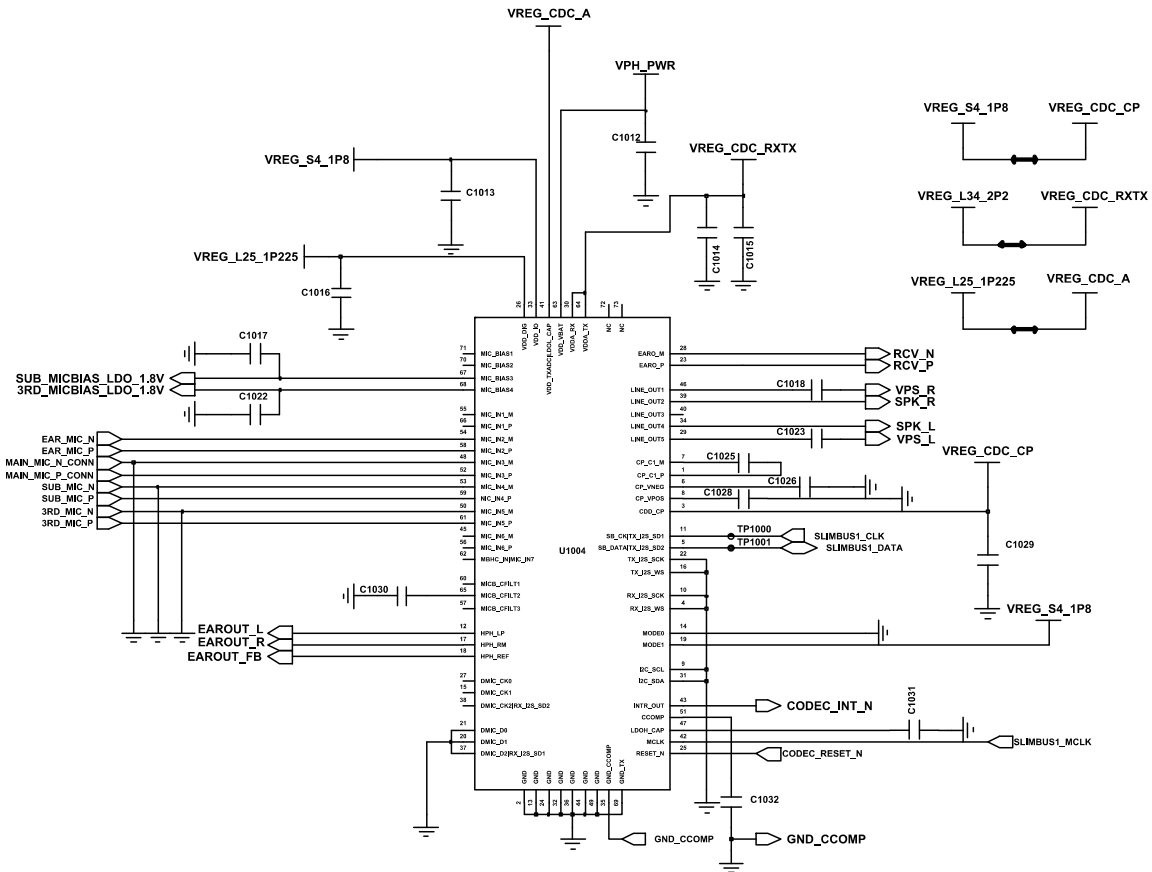
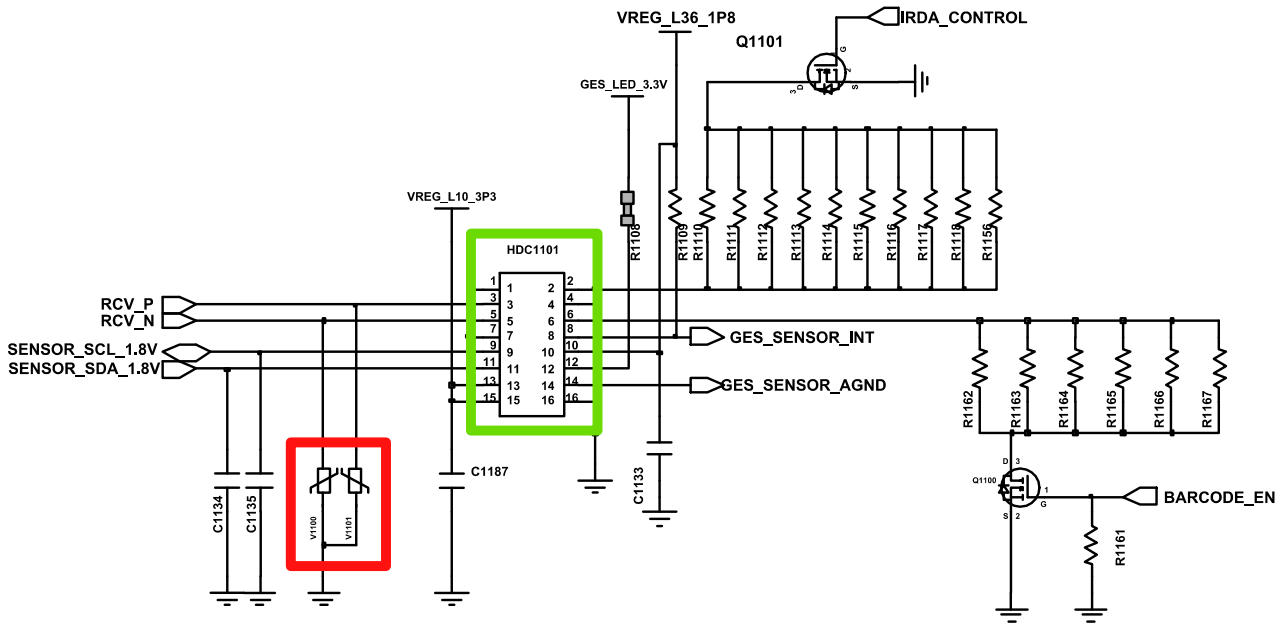

AUDIO CODEC

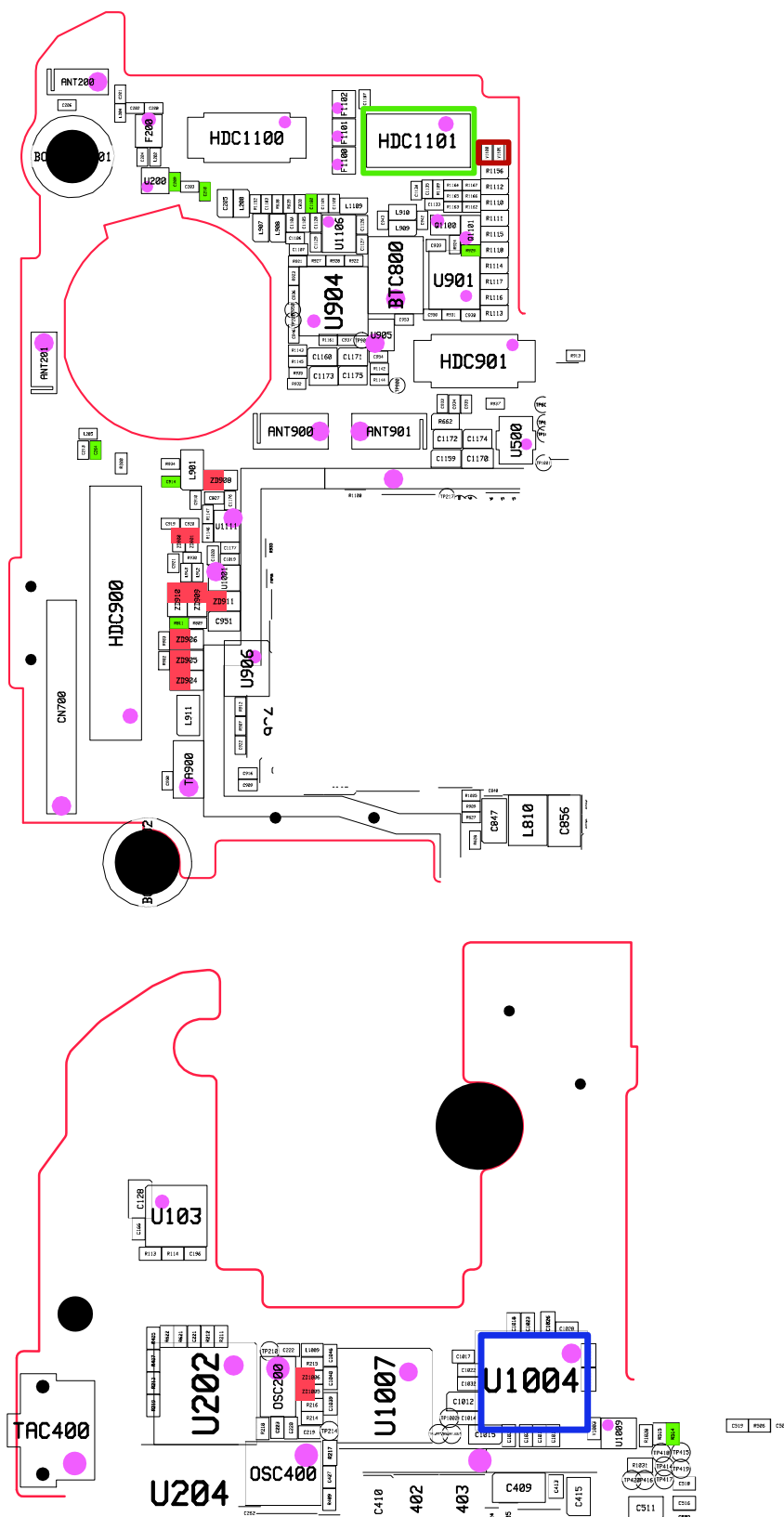

8-3-11. BT/WIFI

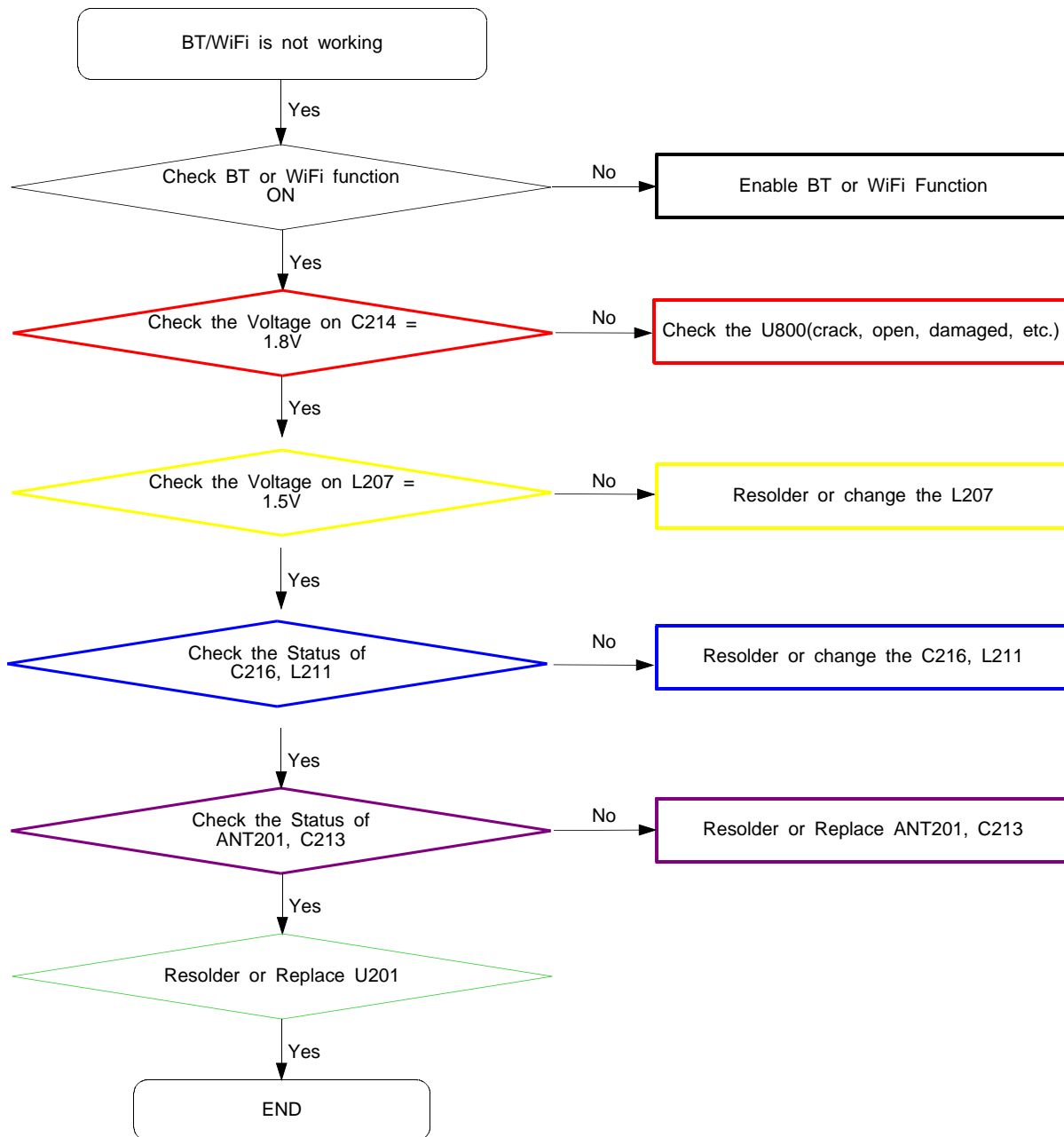

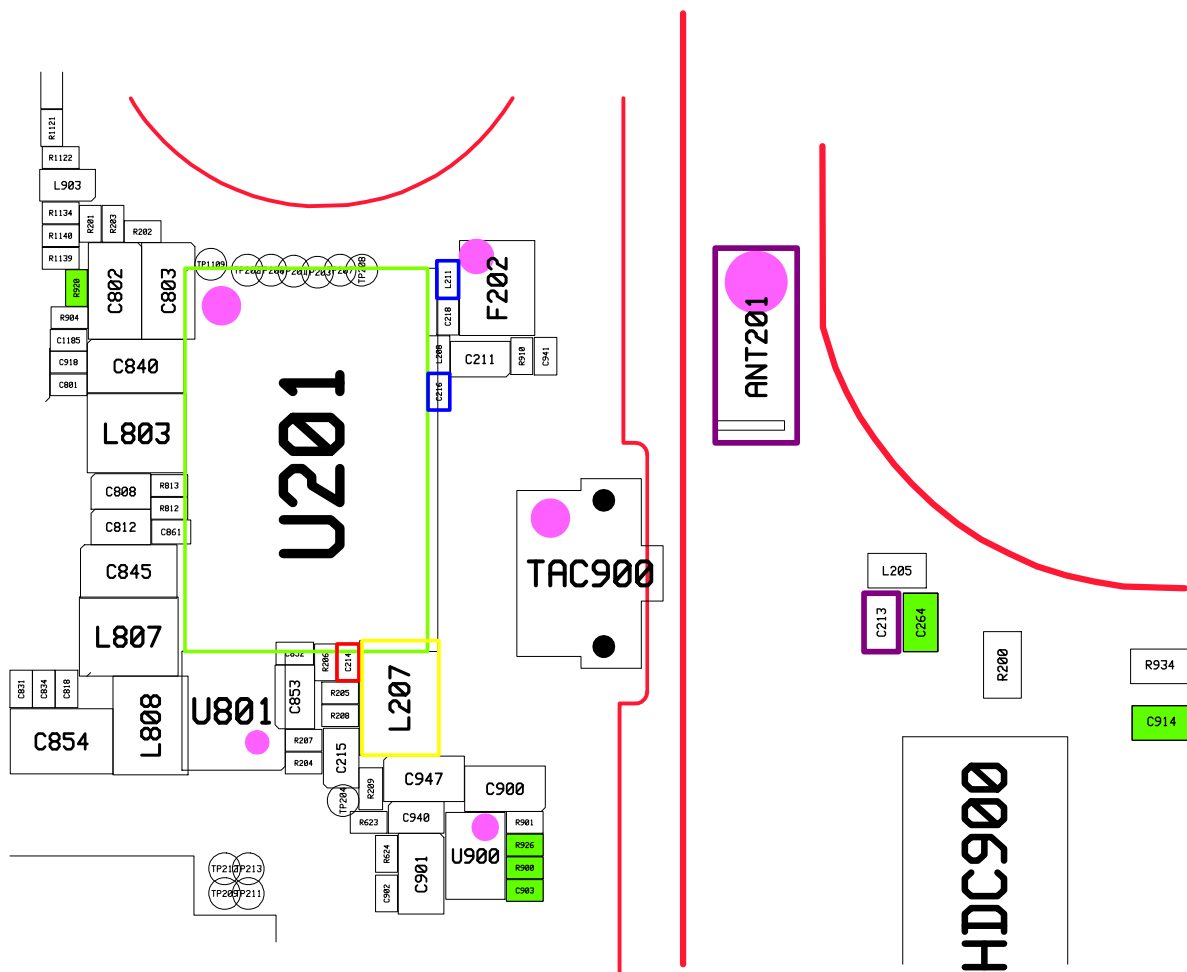
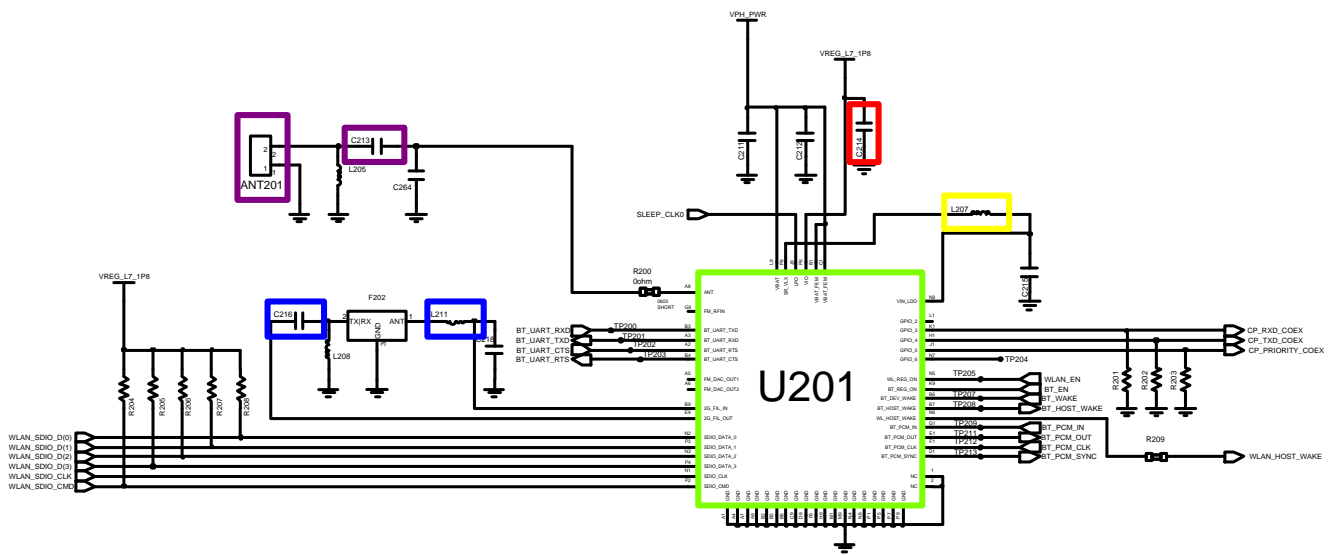

8-3-12. GPS

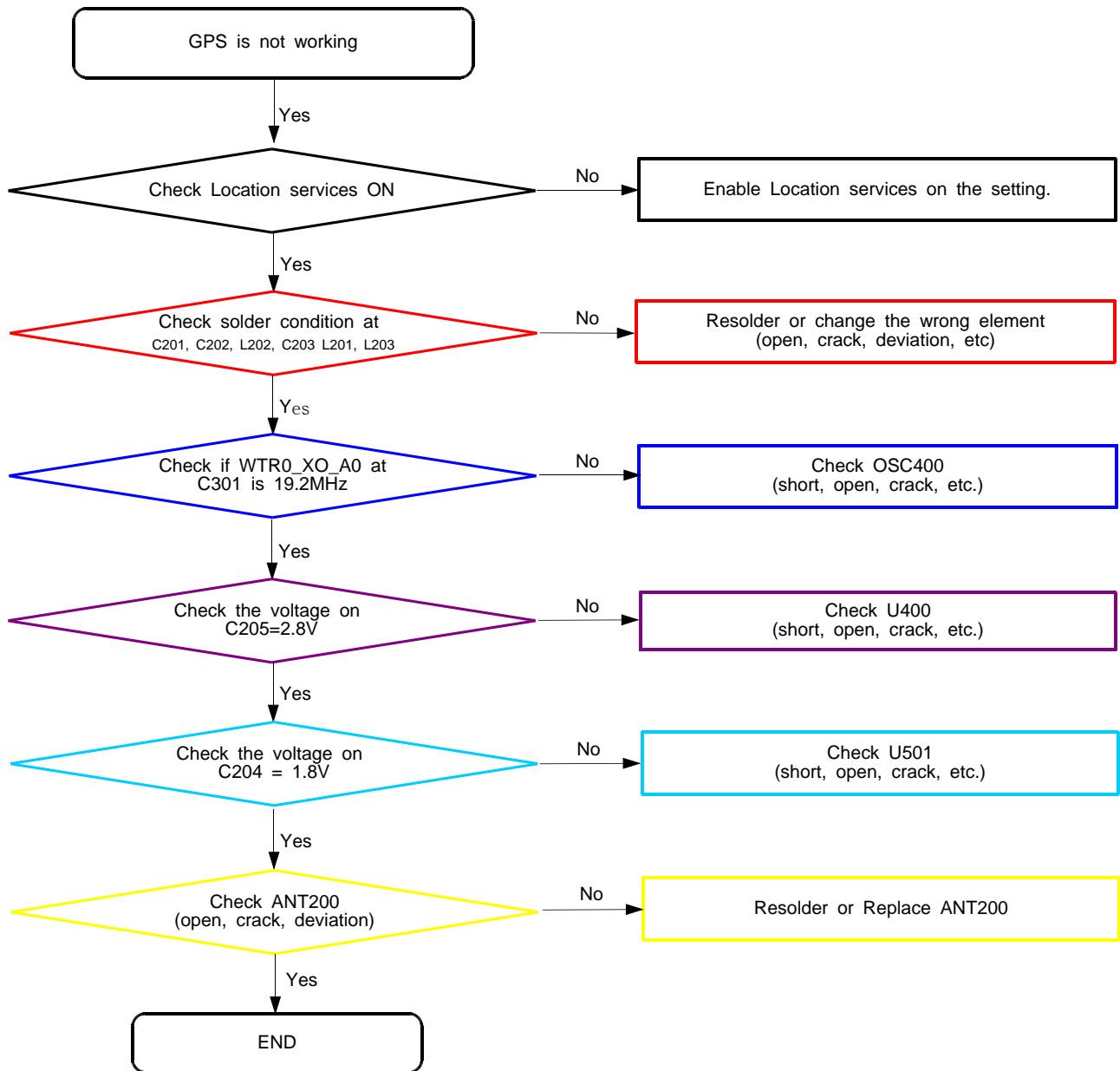

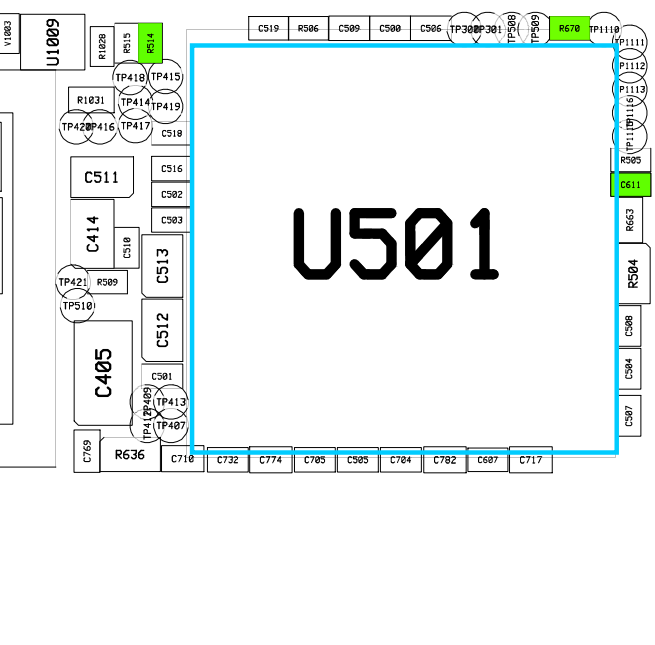
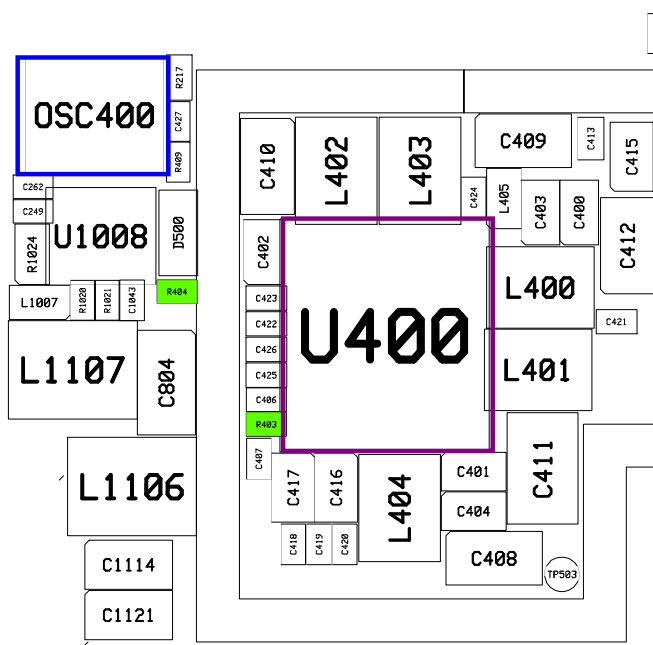
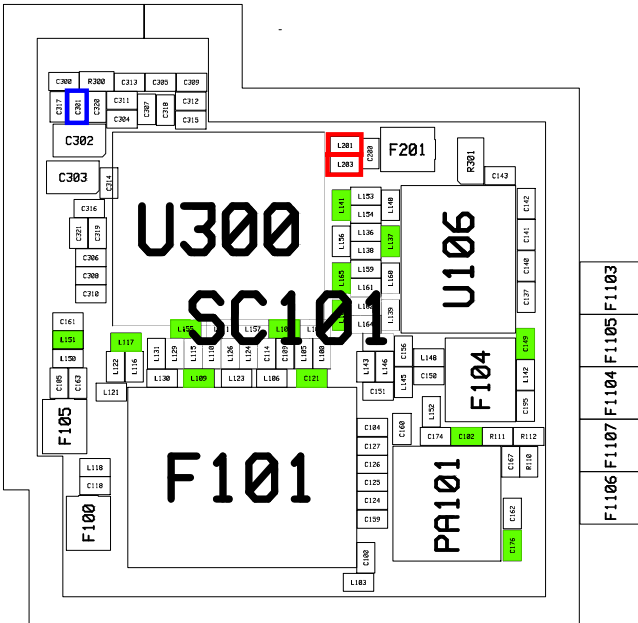
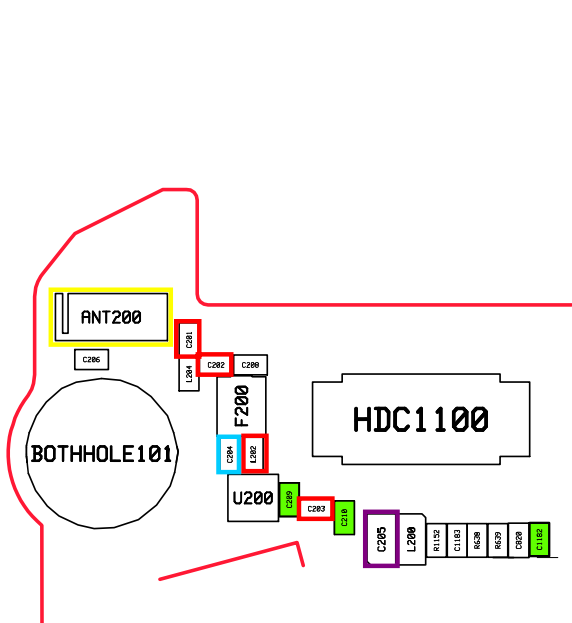
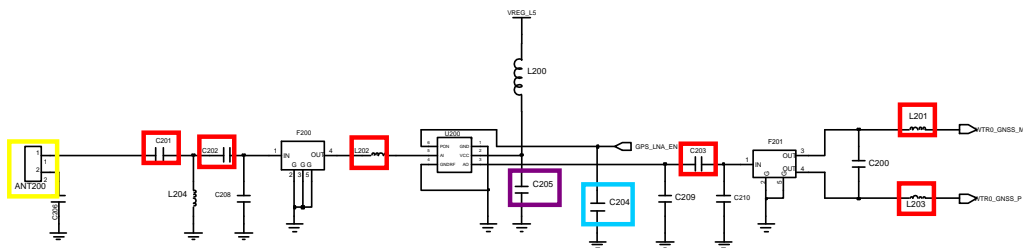

8-3-13. NFC

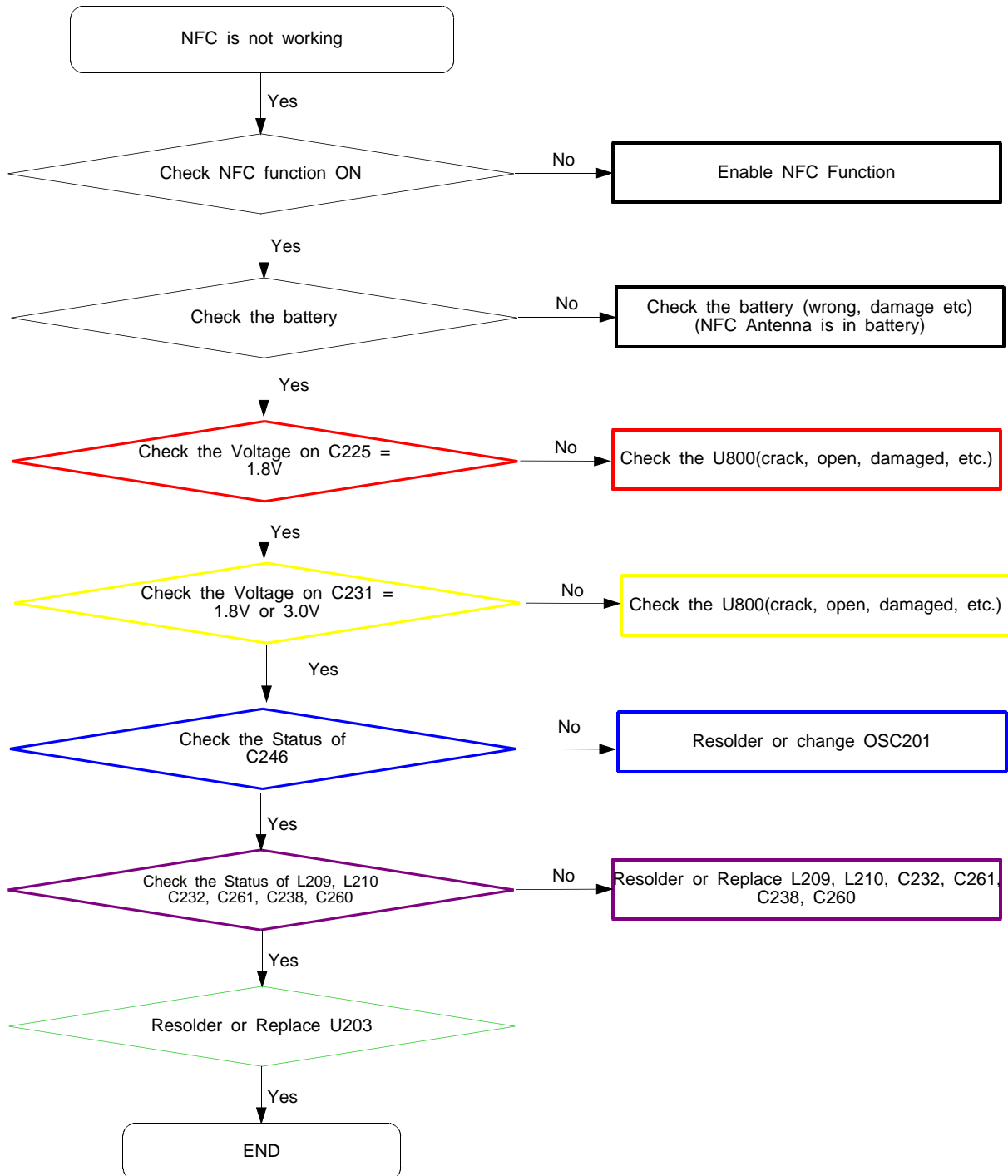

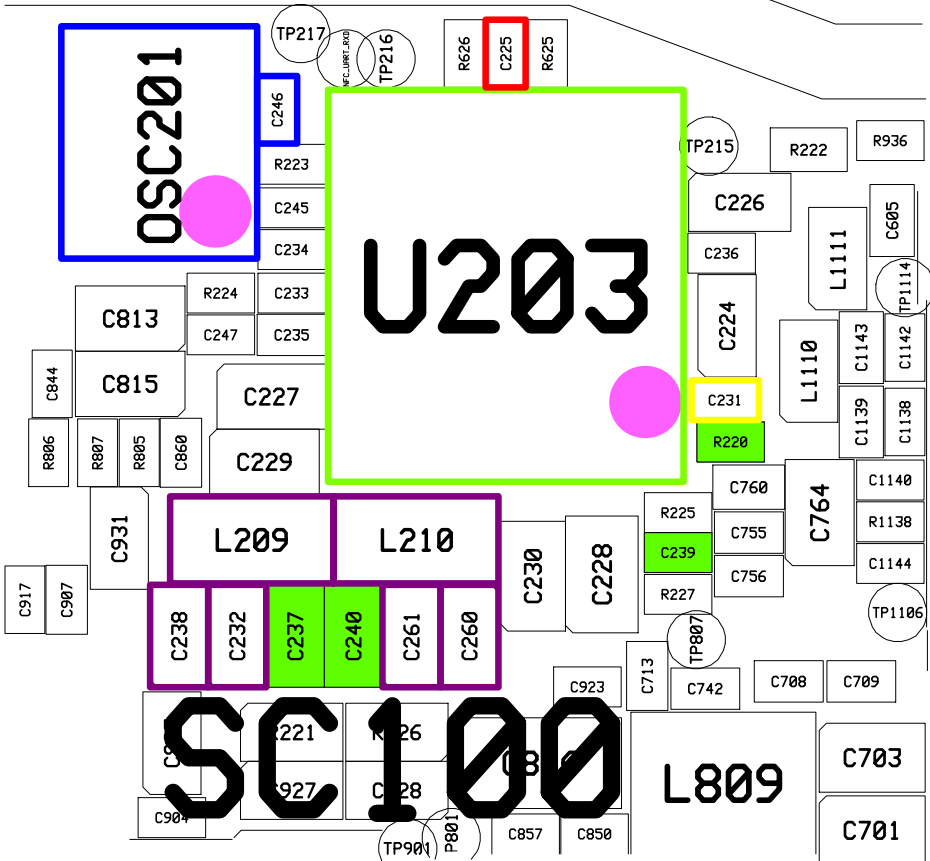
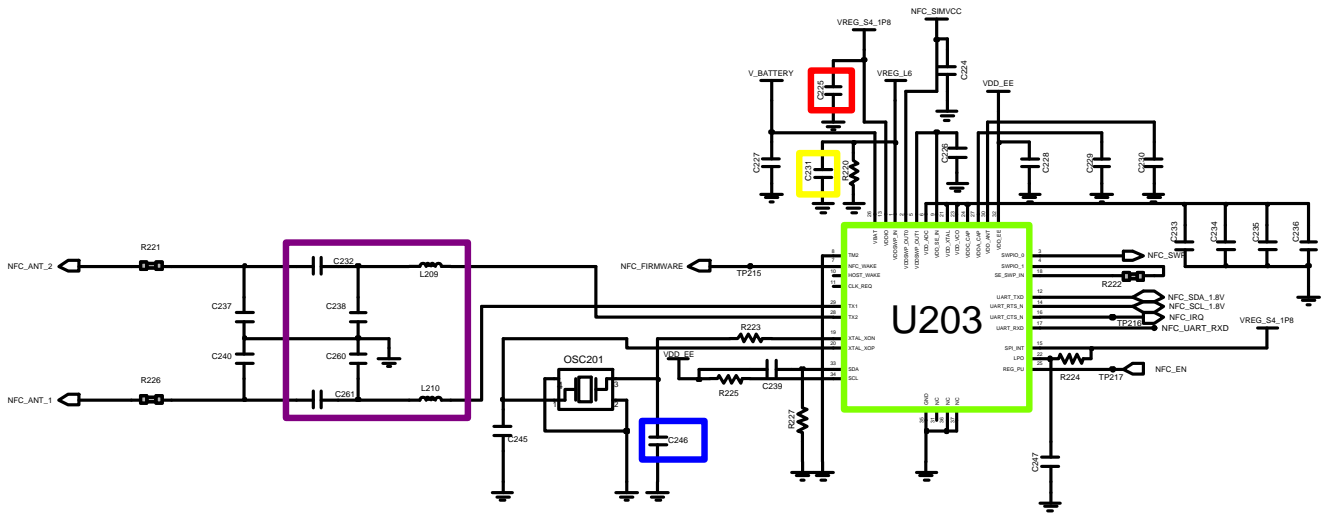

8-3-14. LCD

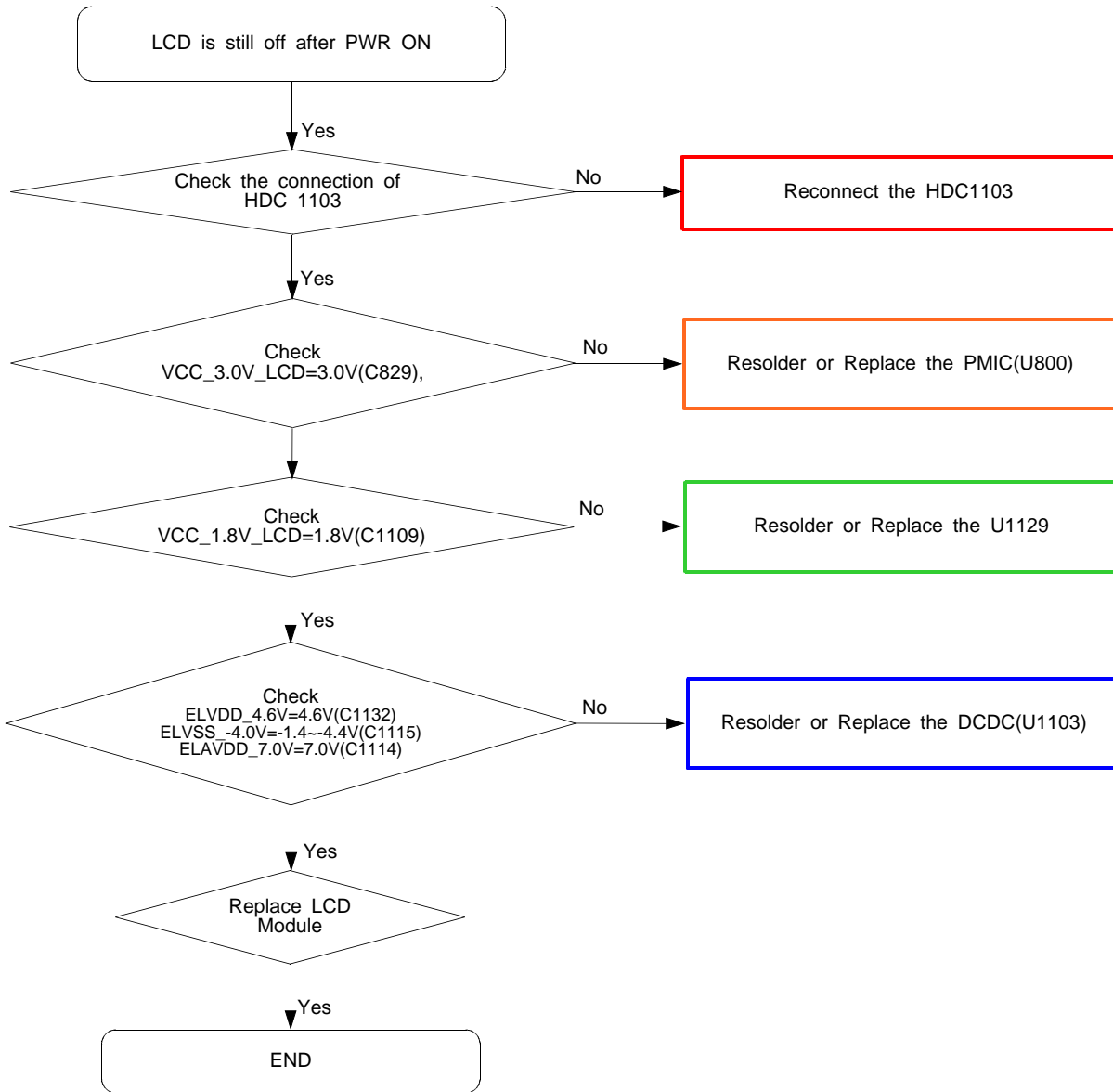

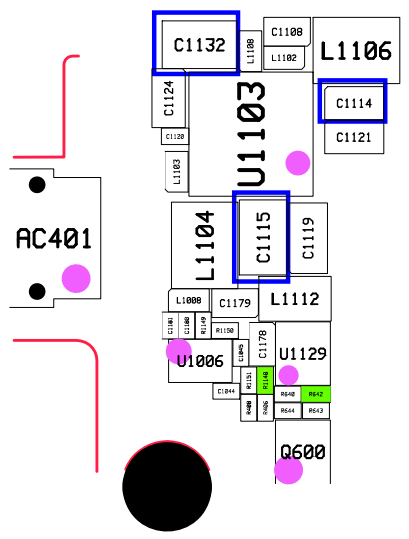
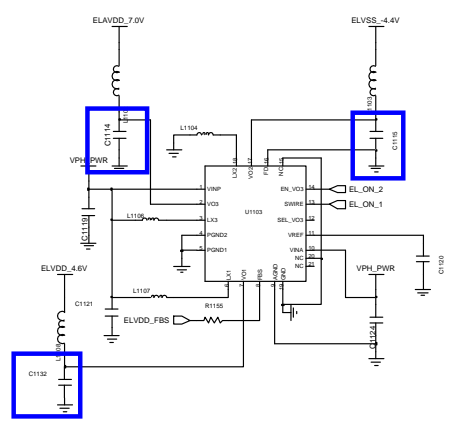
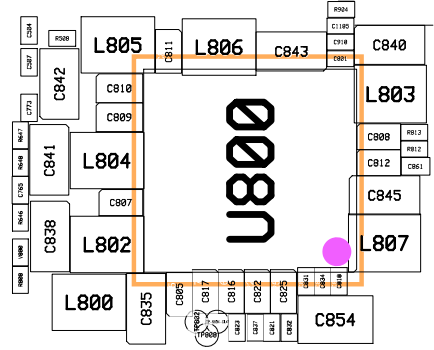
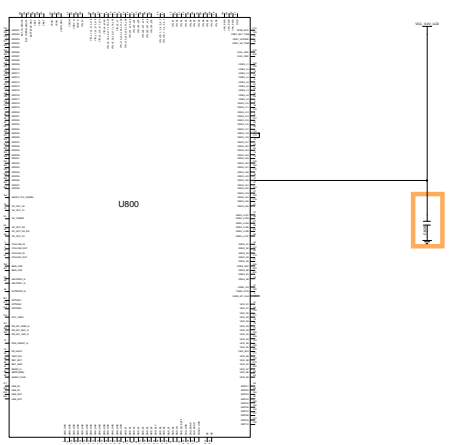
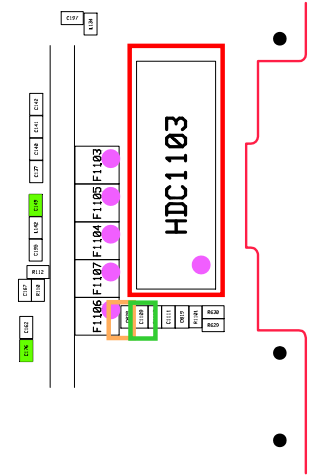
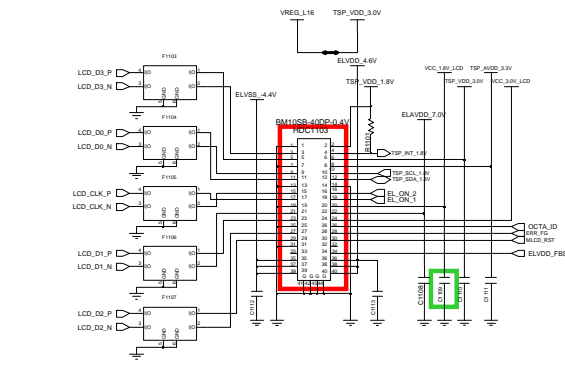

8-3-15. 13M CAM

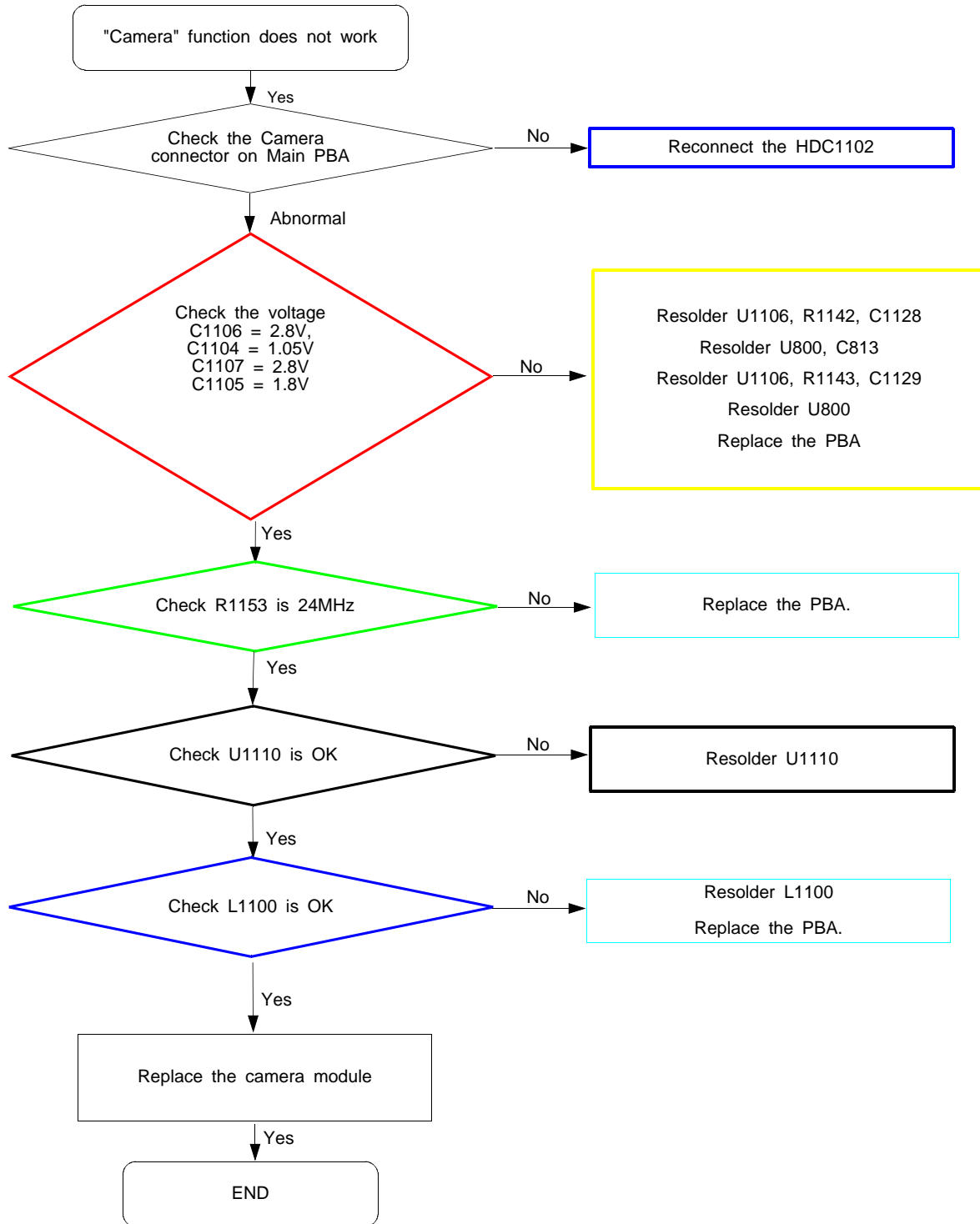

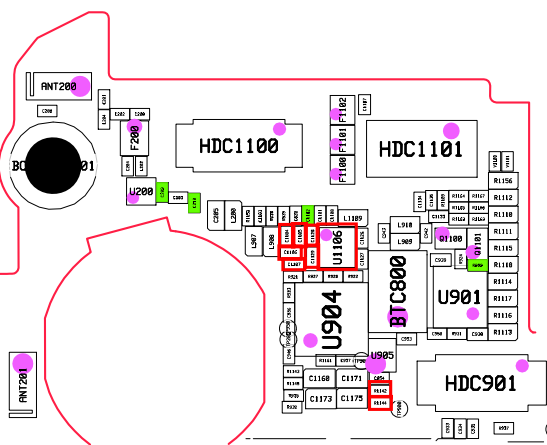
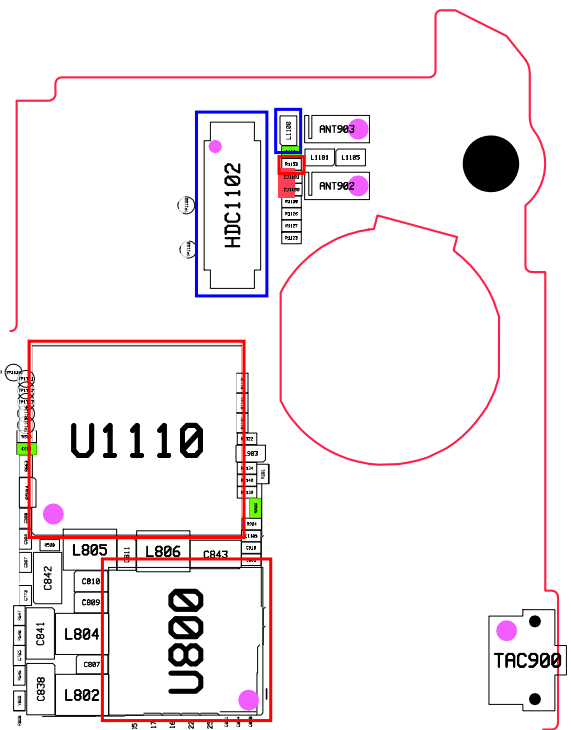
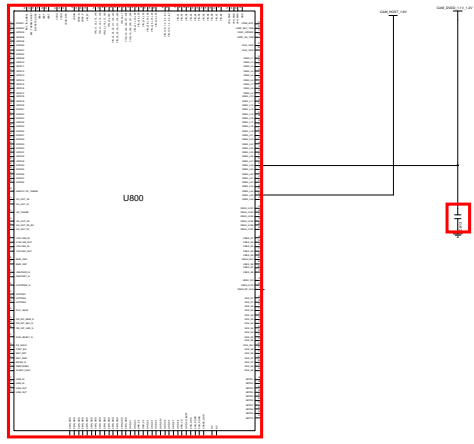
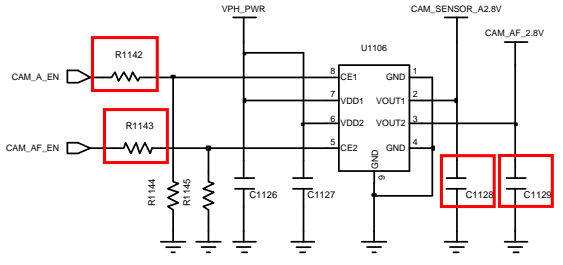
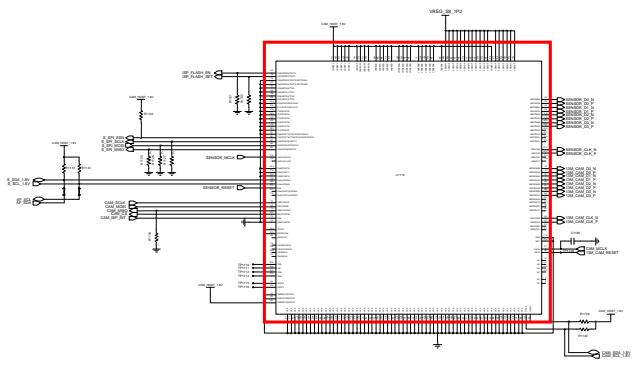
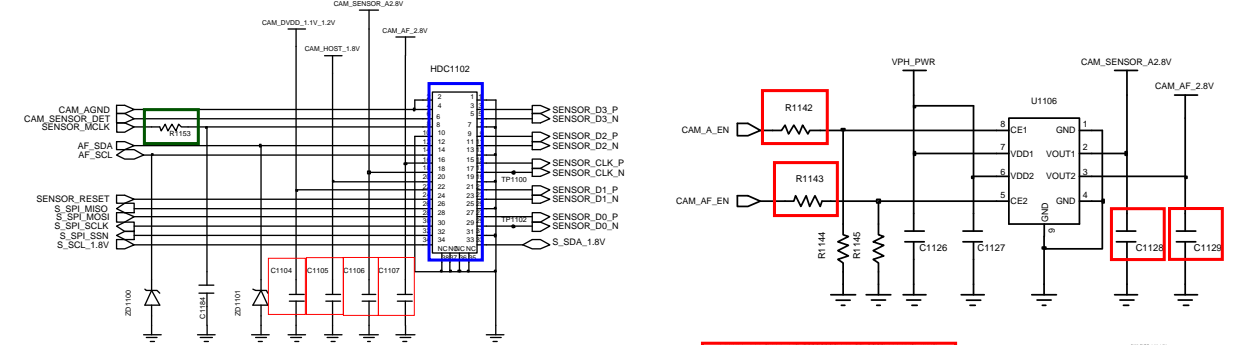

8-3-16. VT CAM

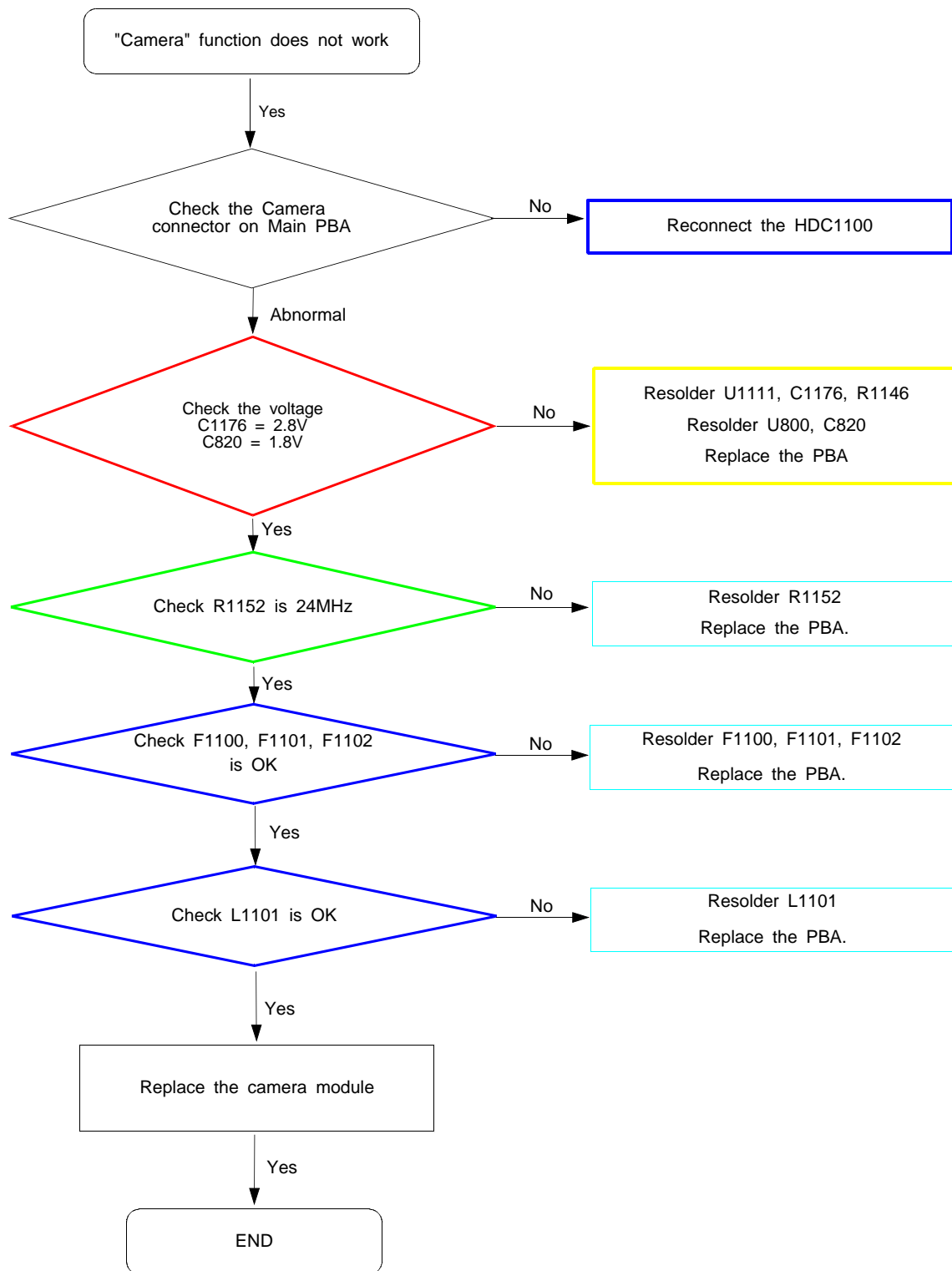

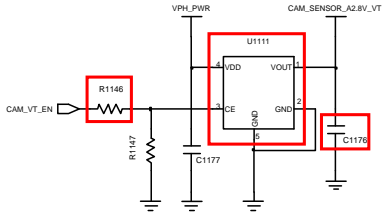
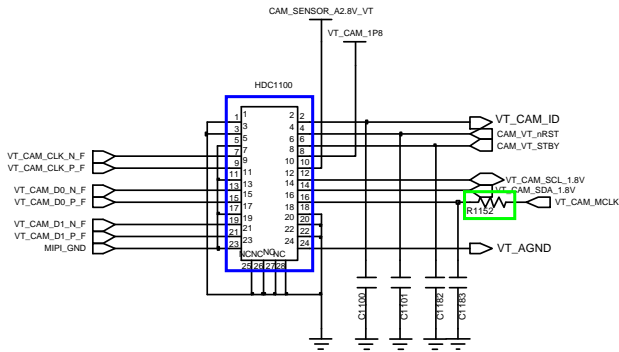

VT_CAMERA LDO

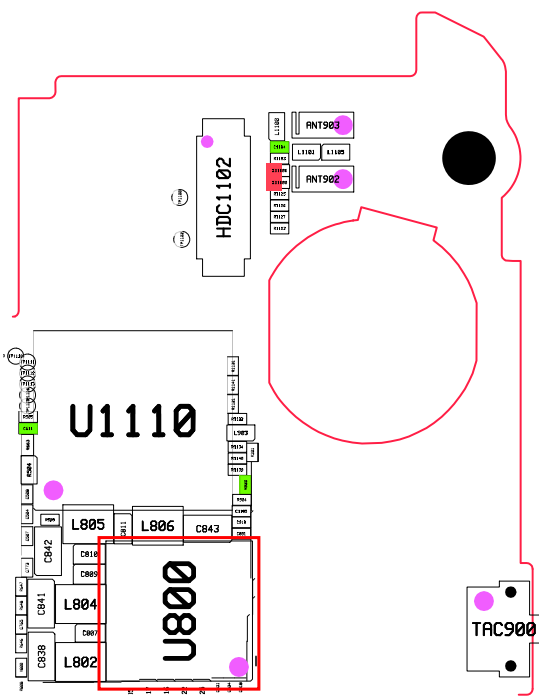
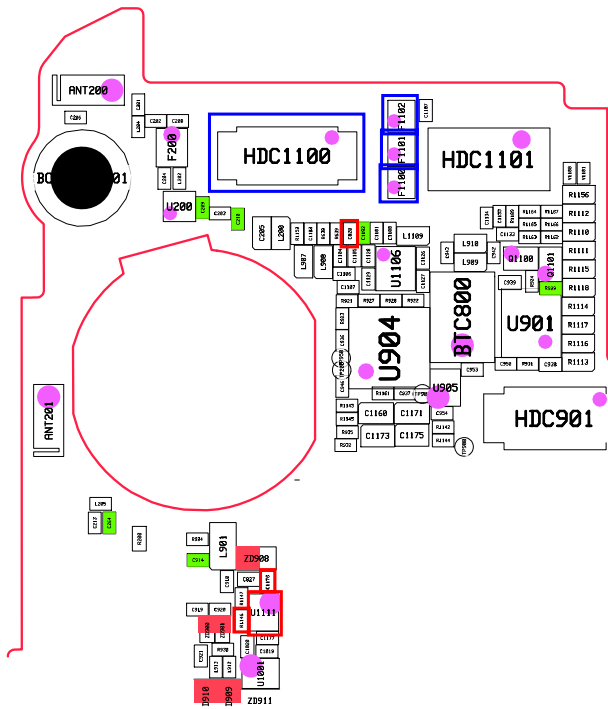
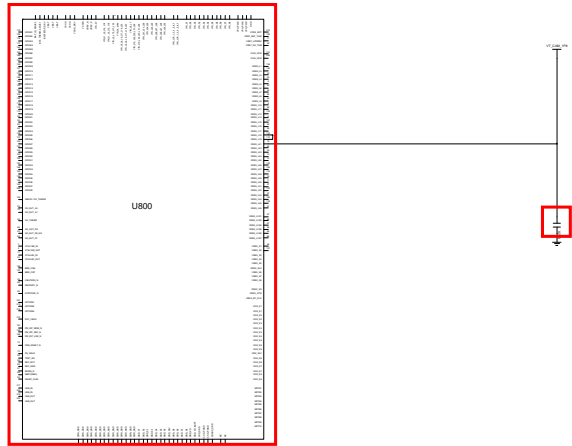
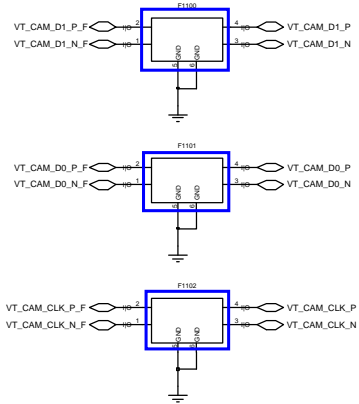

8-3-17. MHL

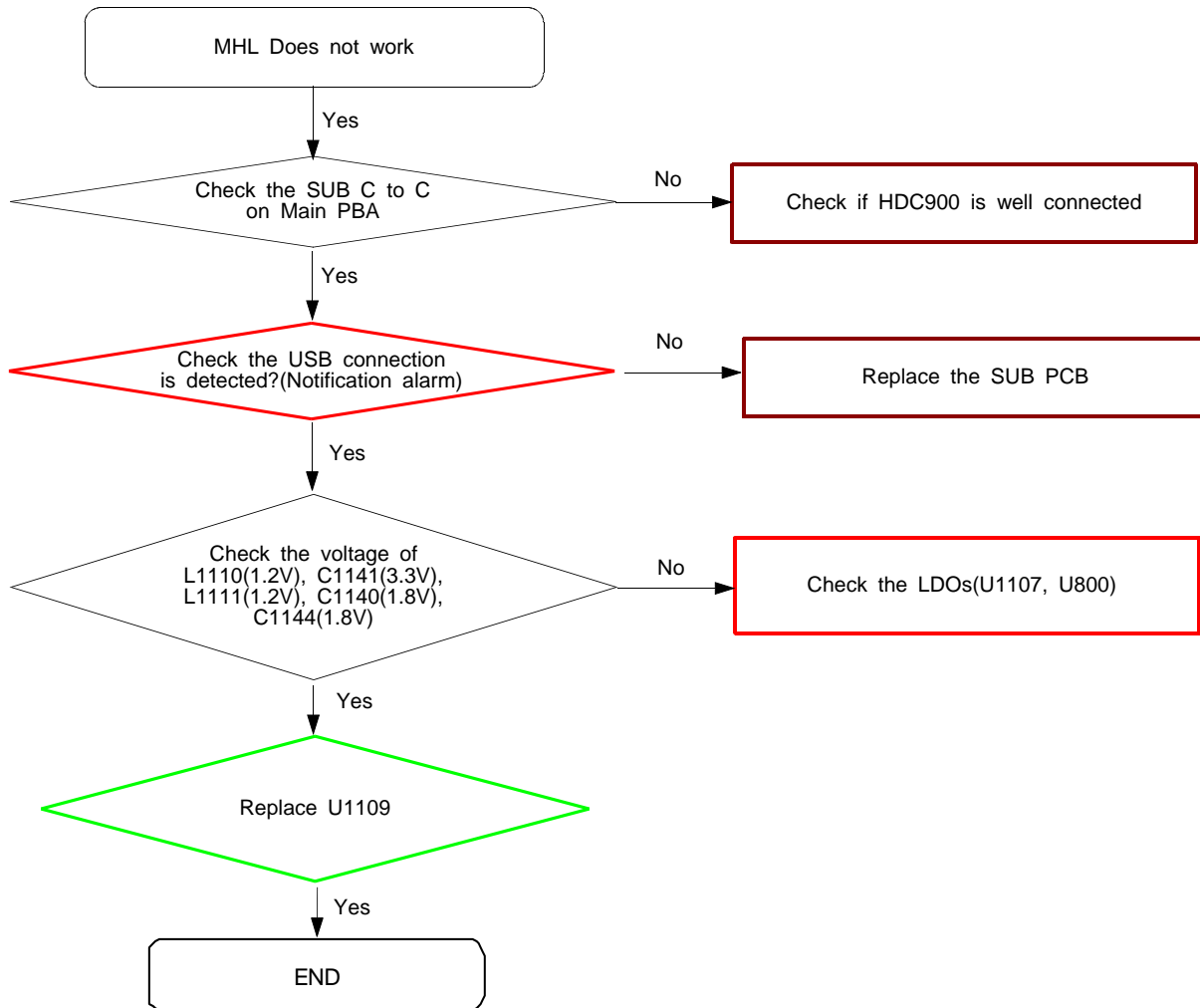

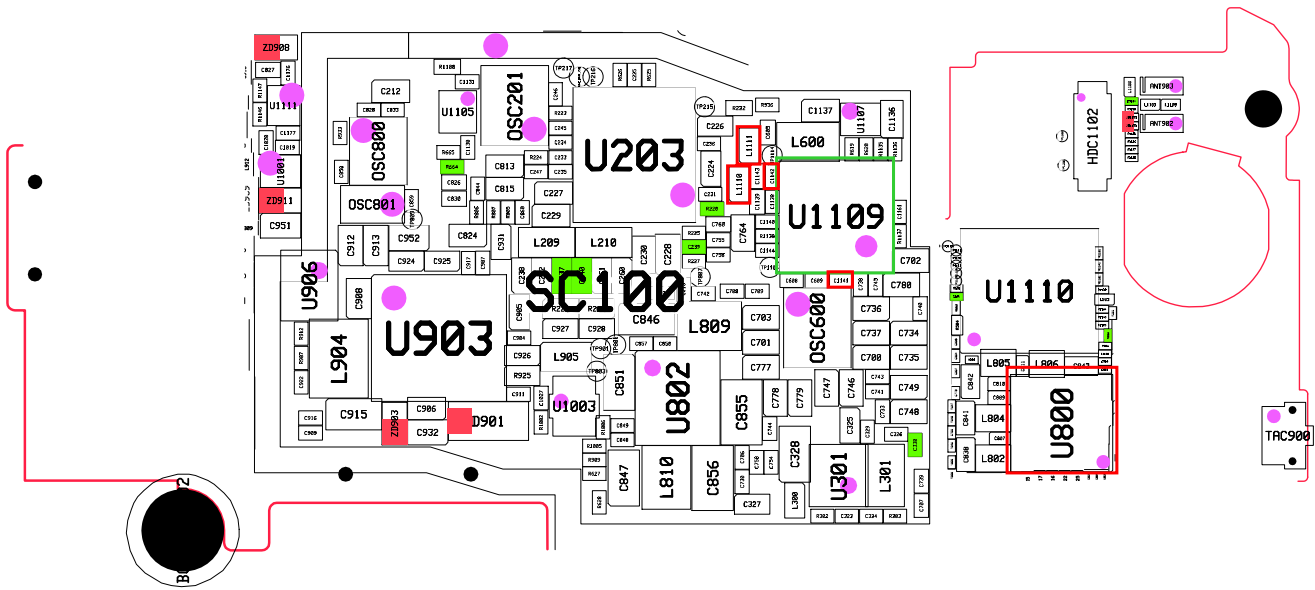
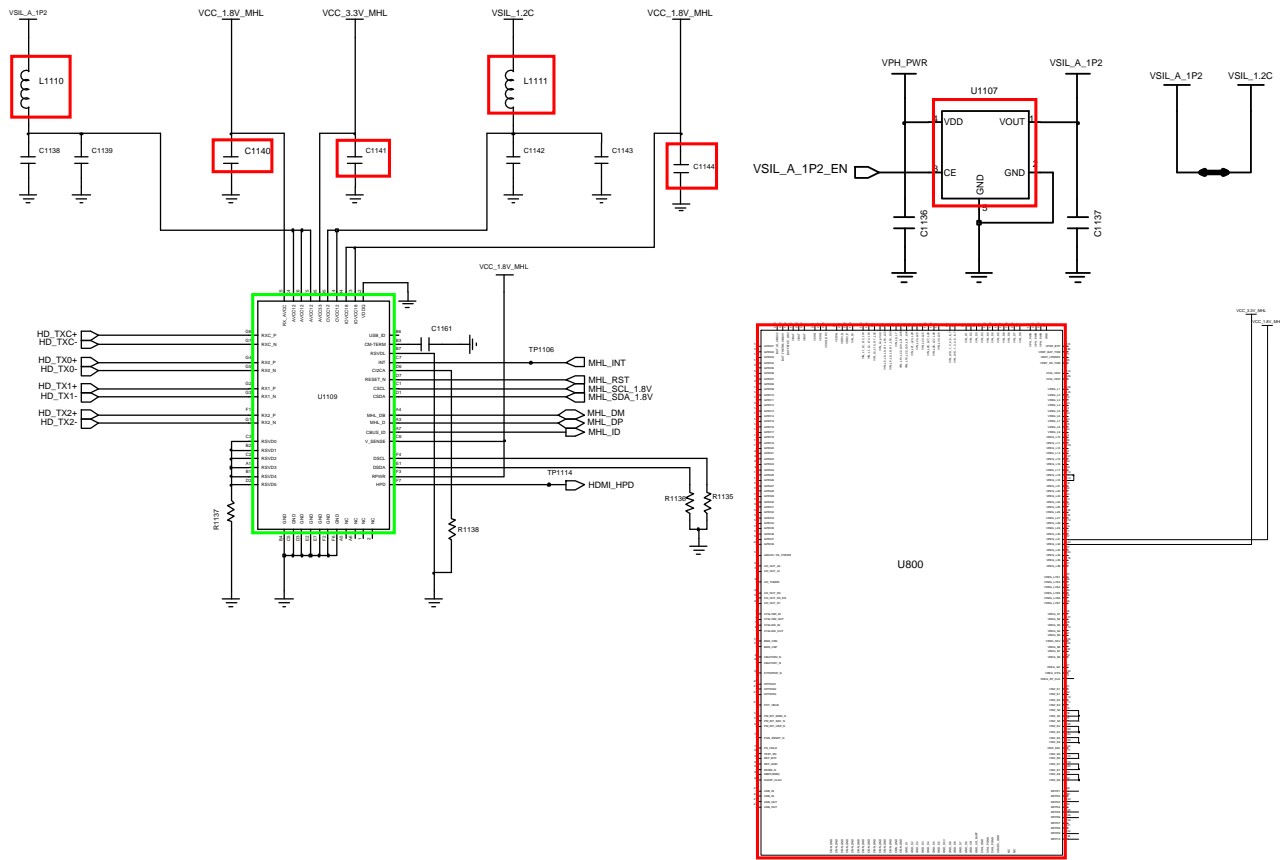

8-3-18. TSP

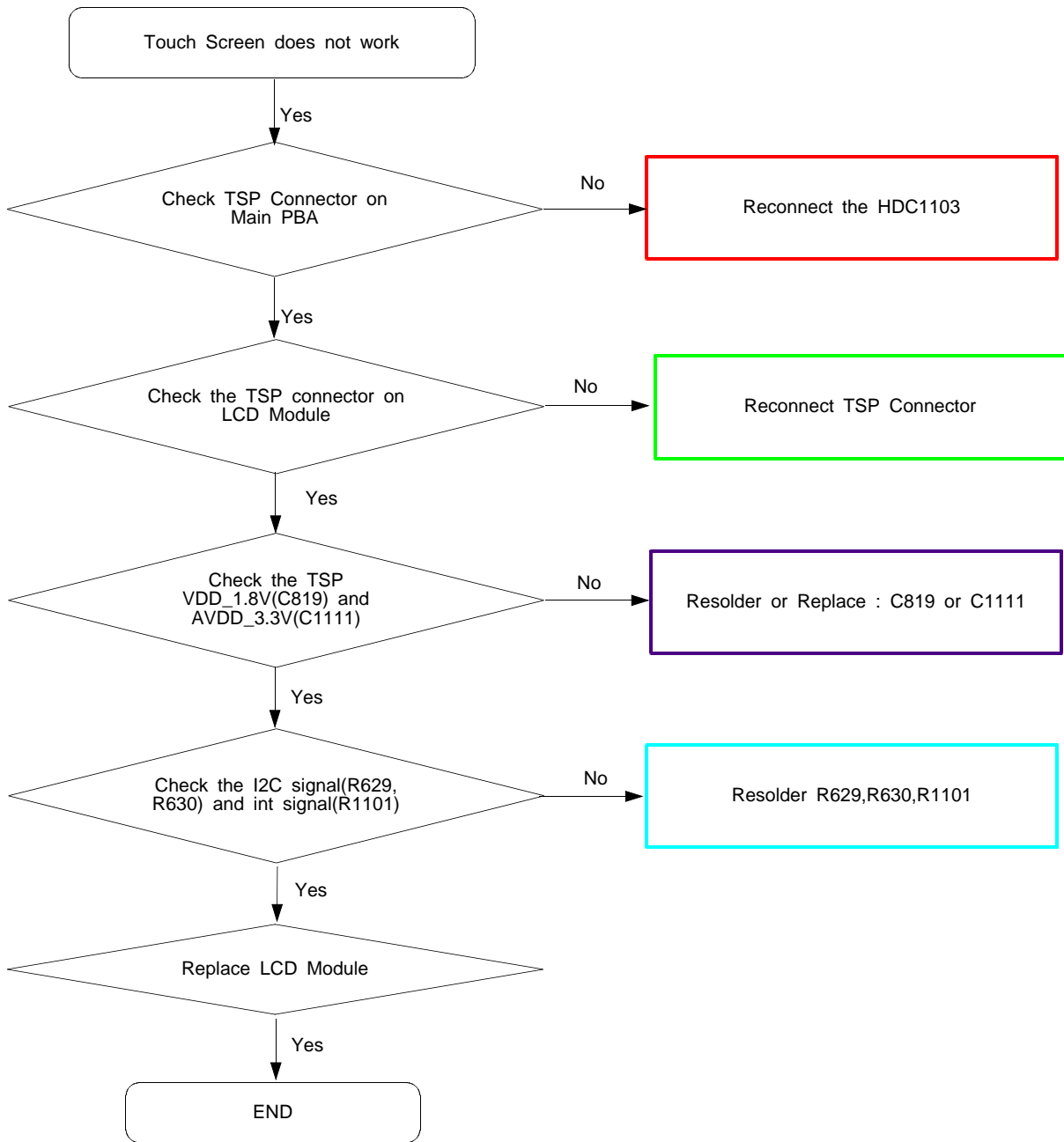

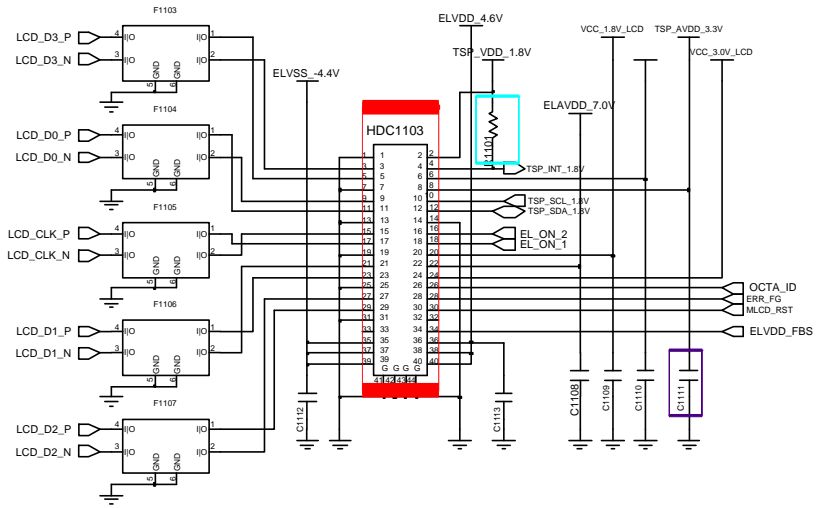
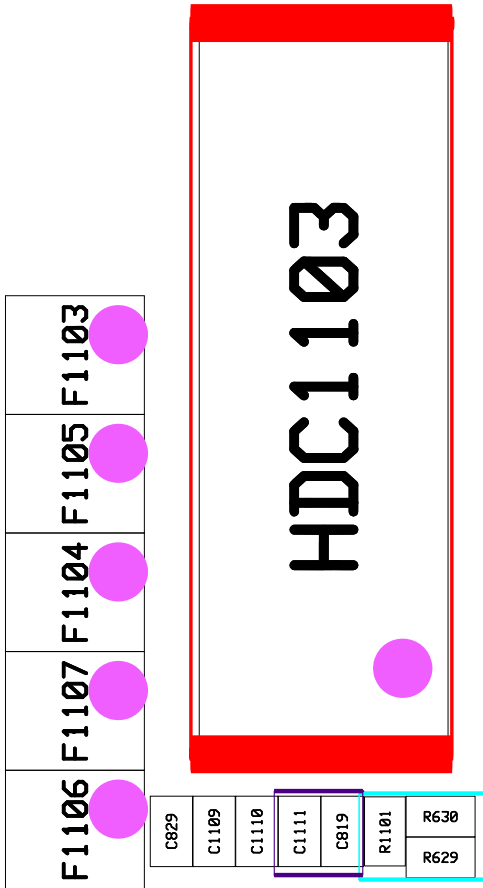

8-3-19. IRLED

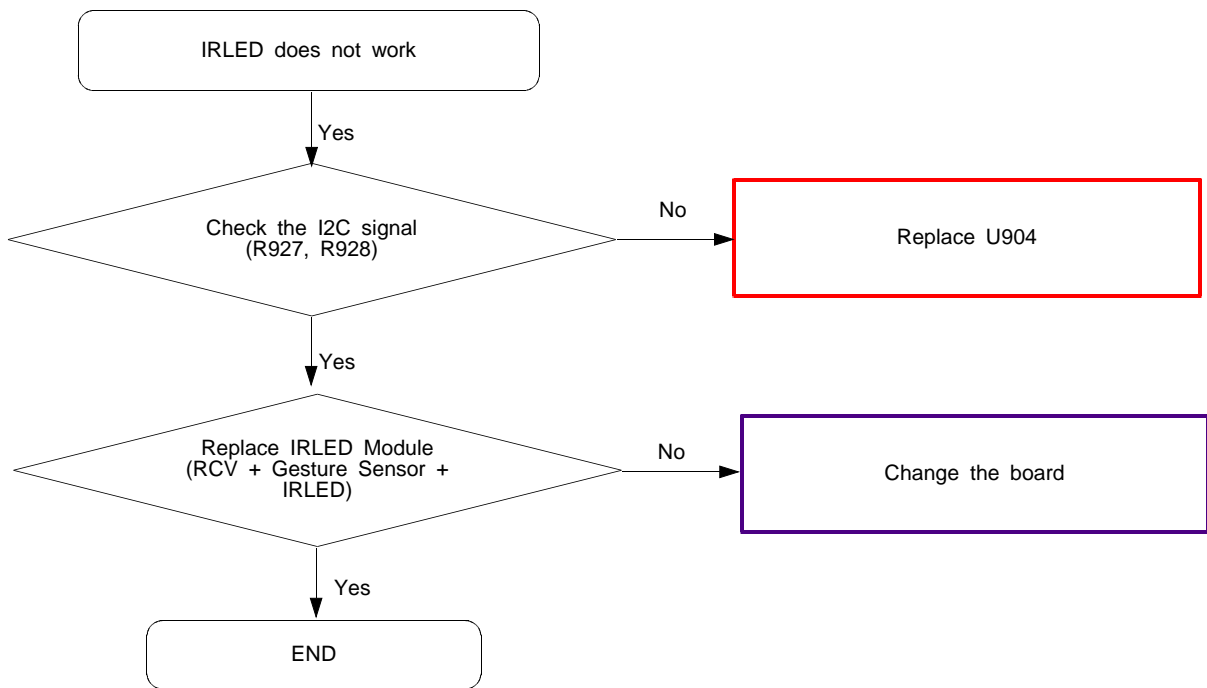

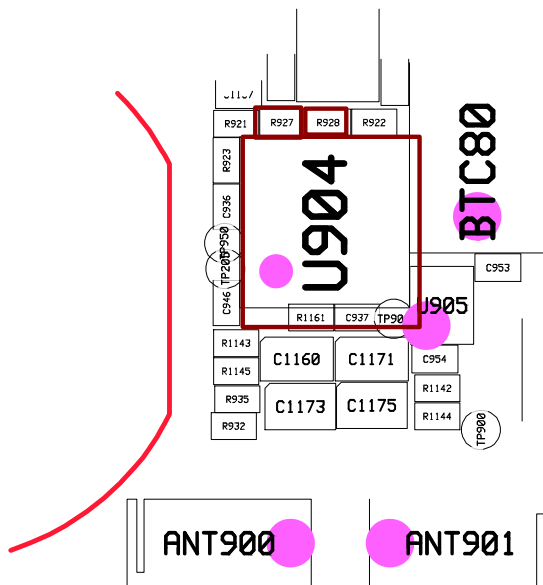
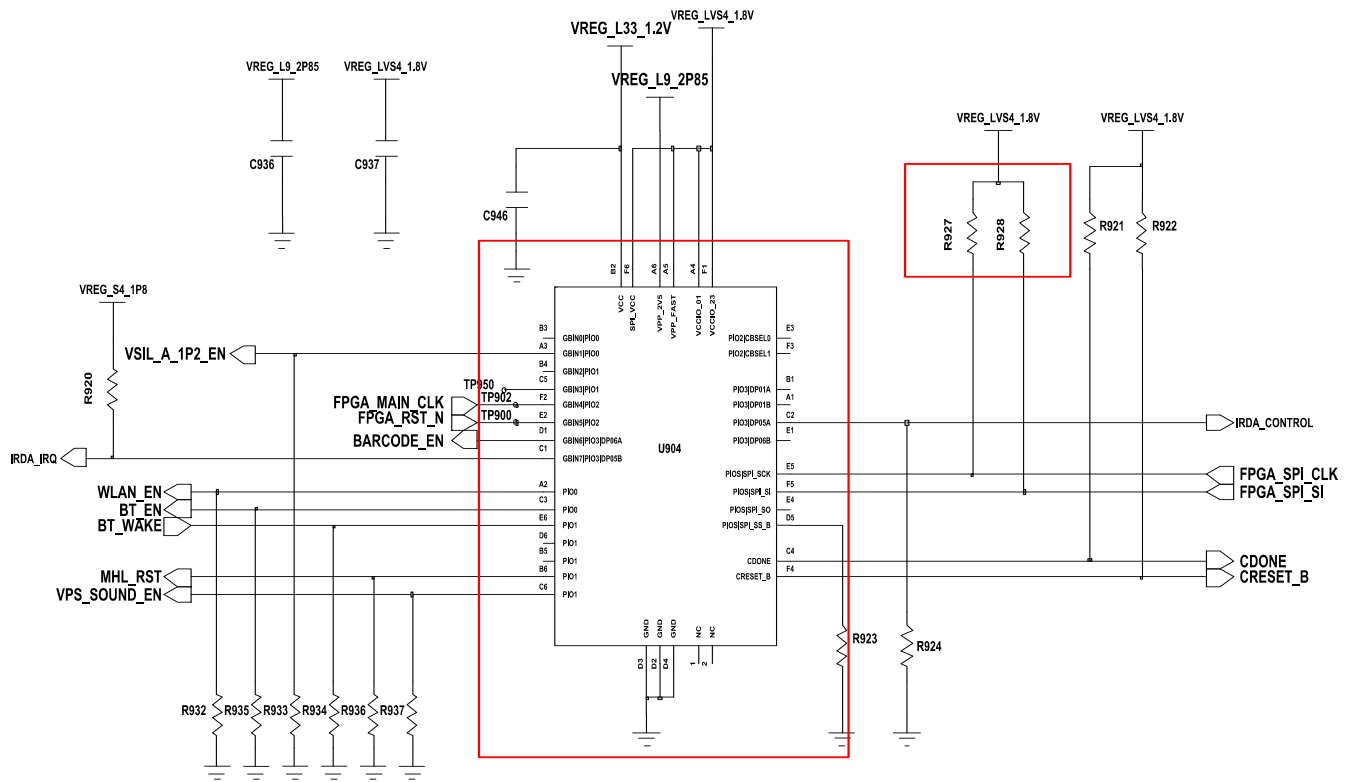

8-3-20. Motor

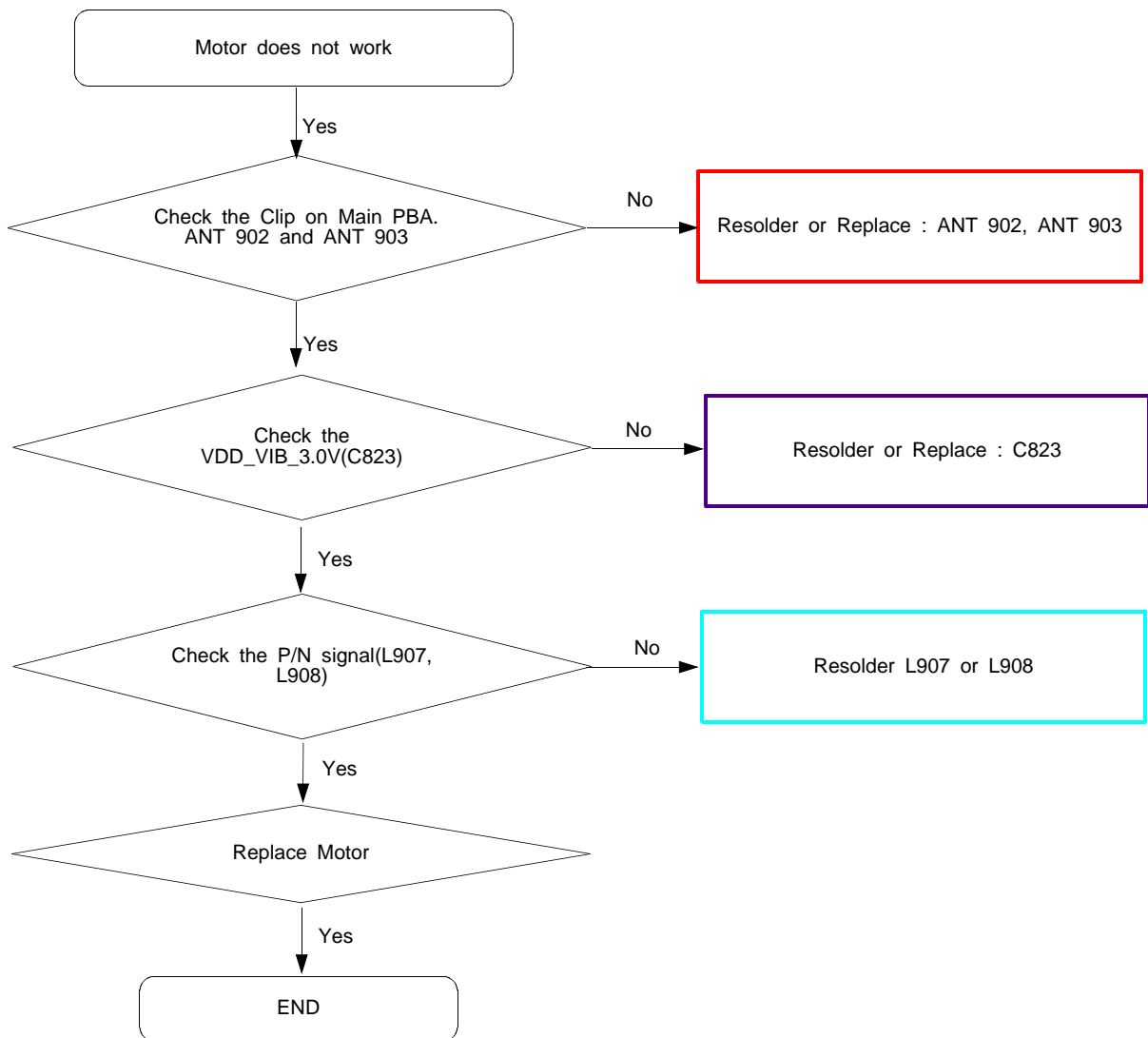

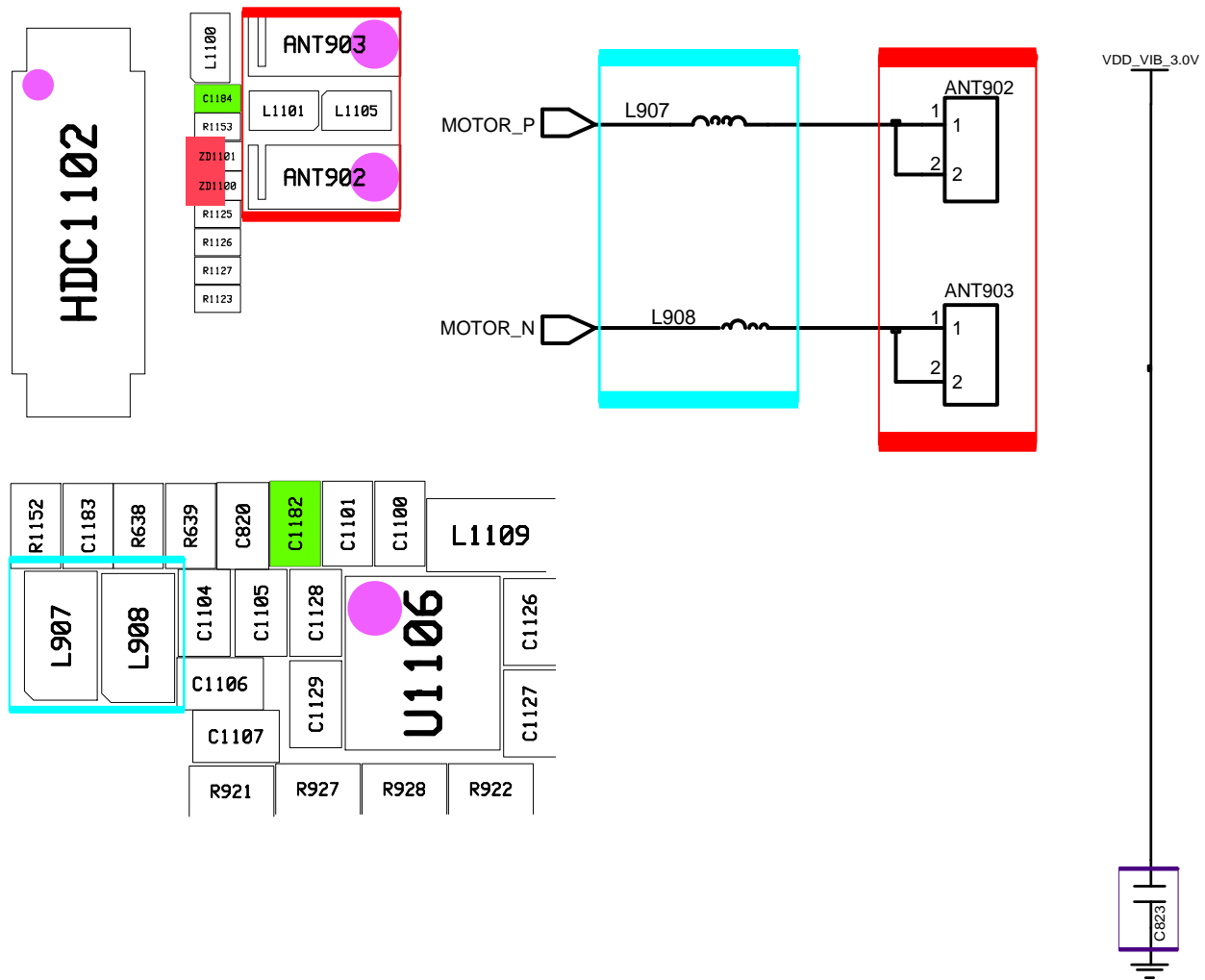

8-3-21. GSM850 RX

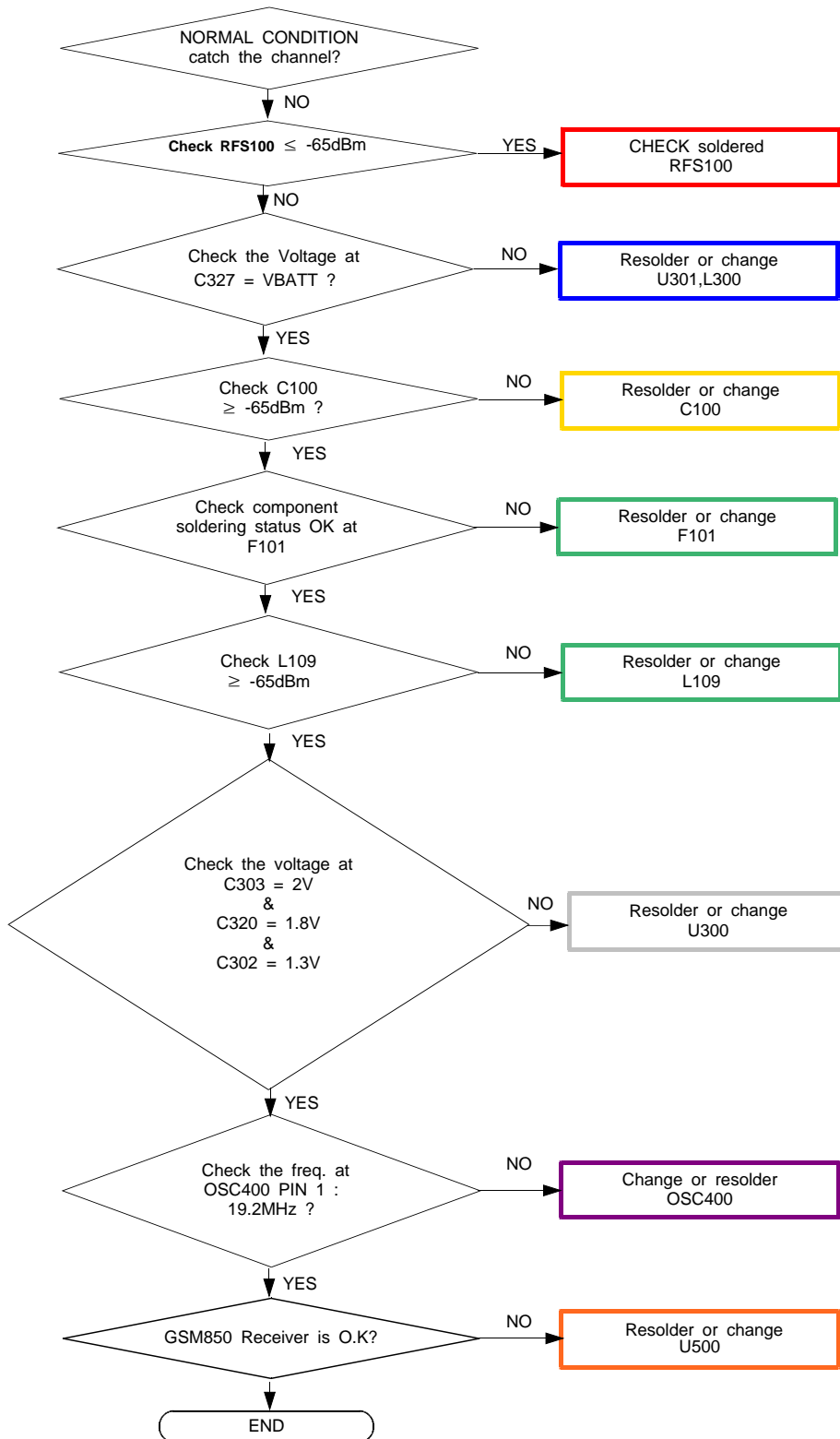

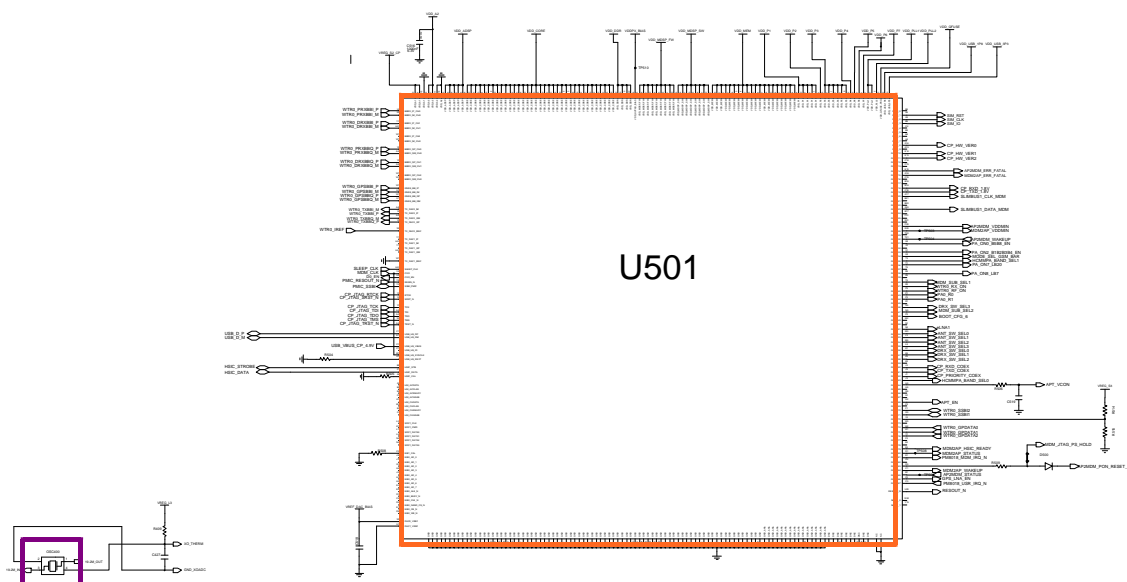
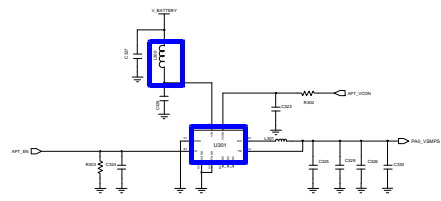
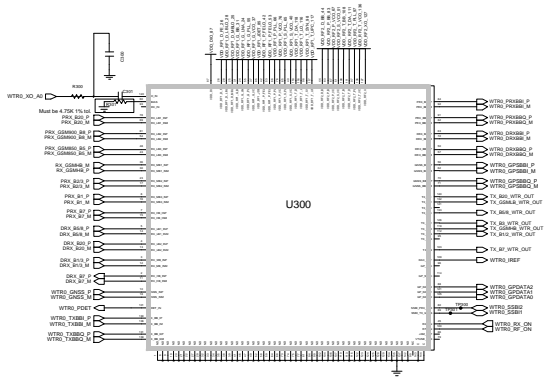
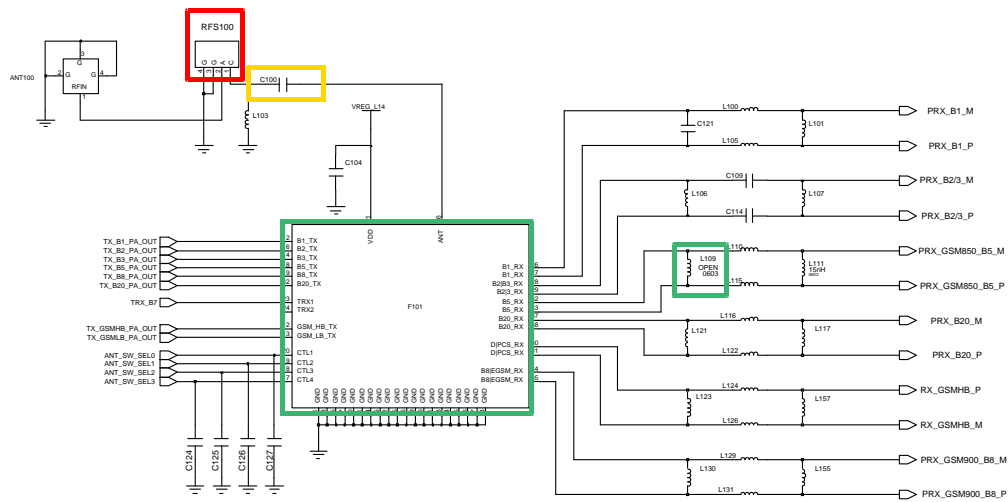

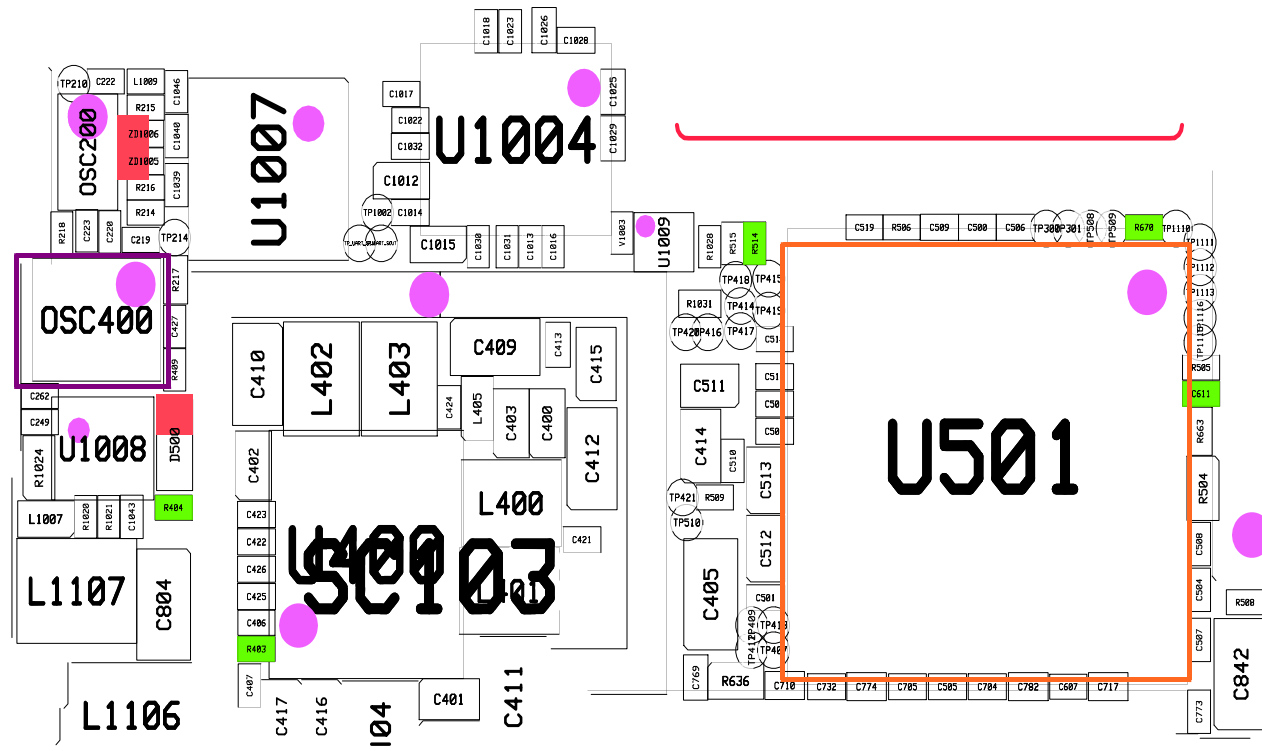
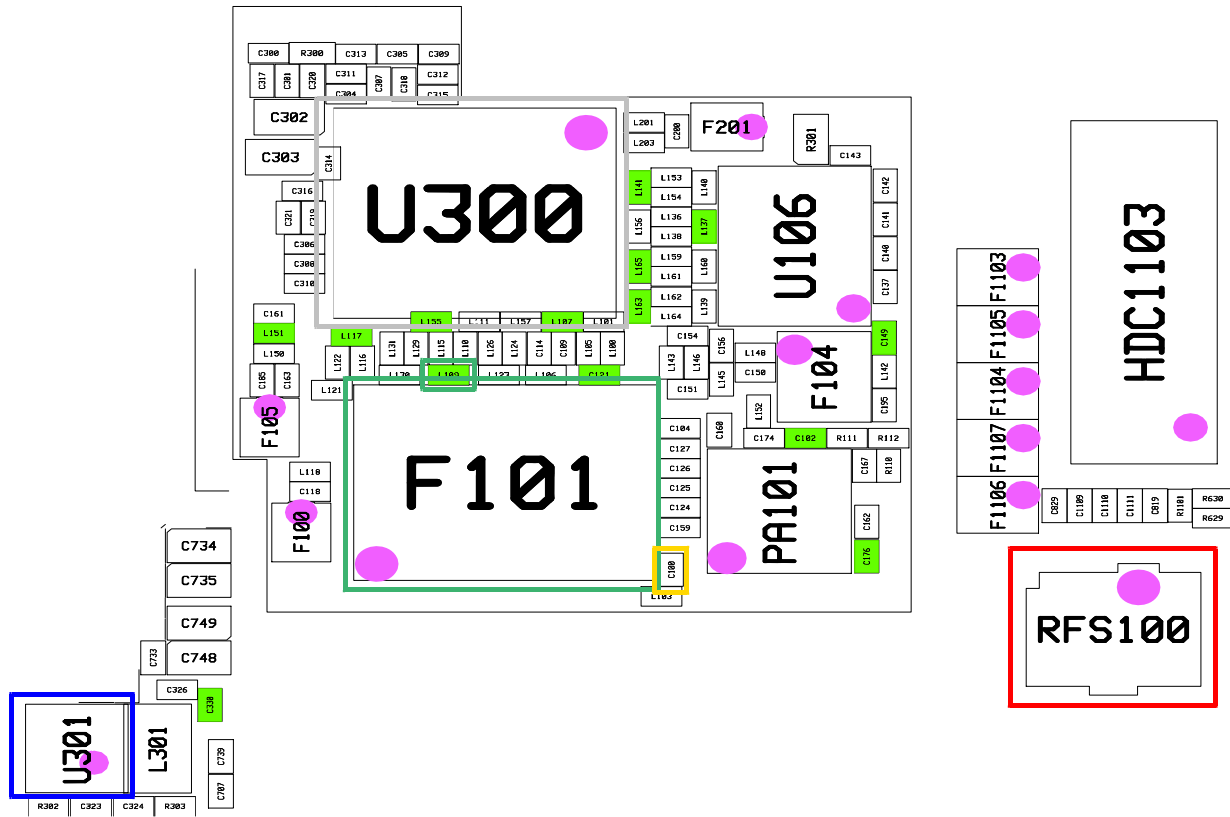

8-3-22. GSM900 RX

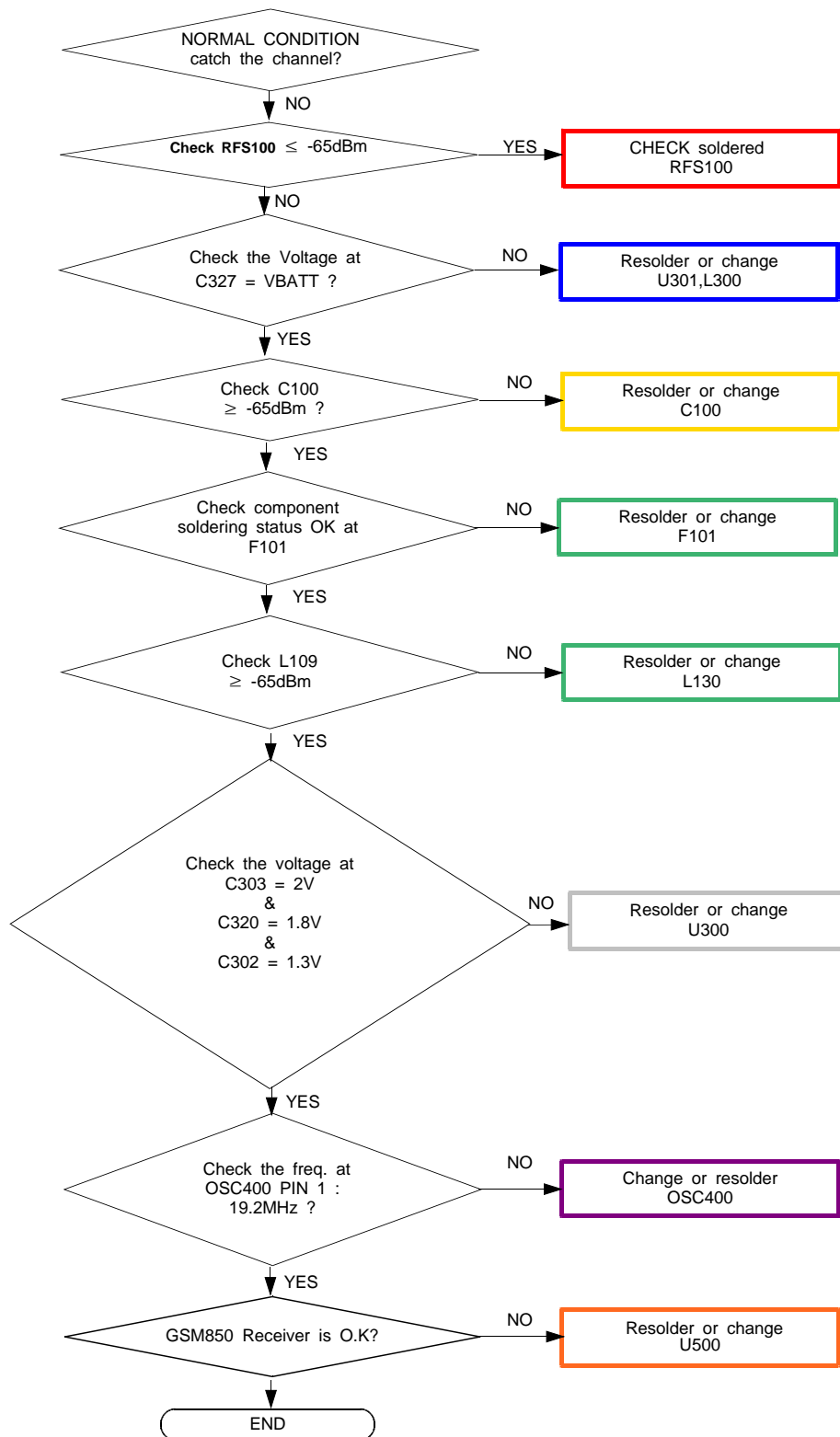

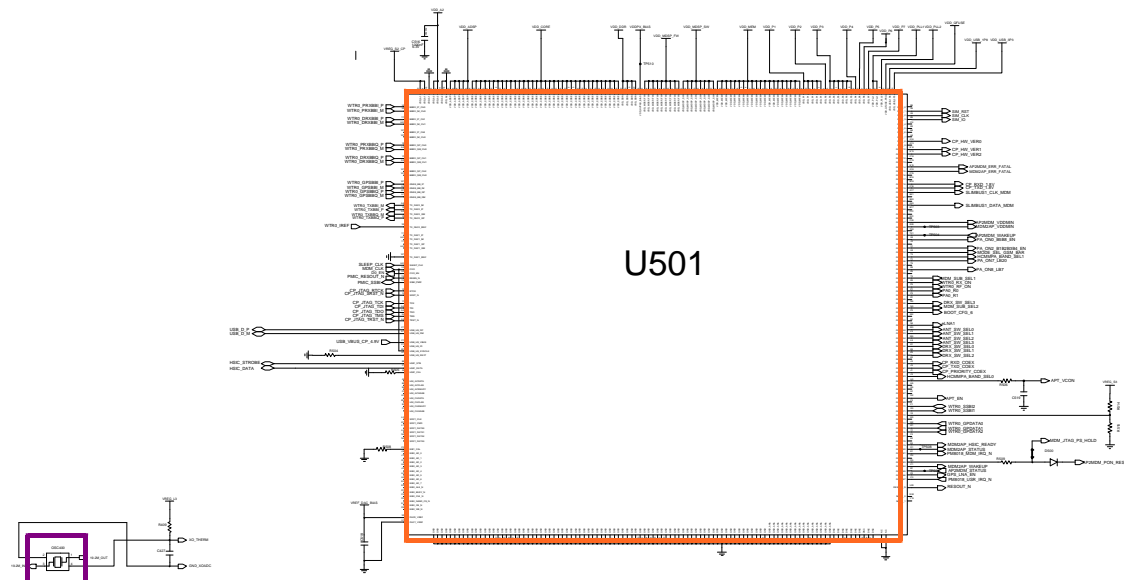
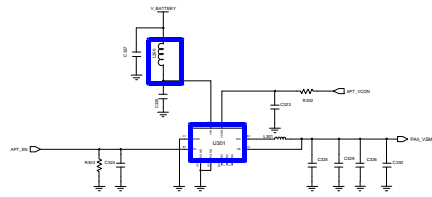
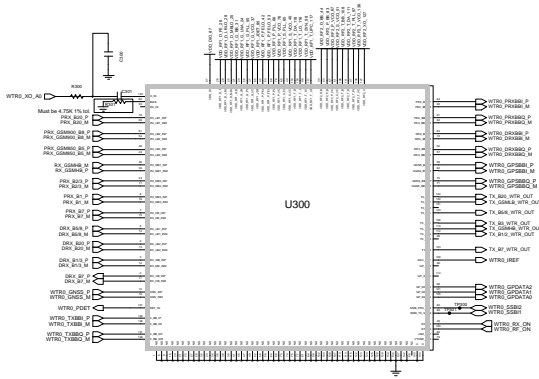
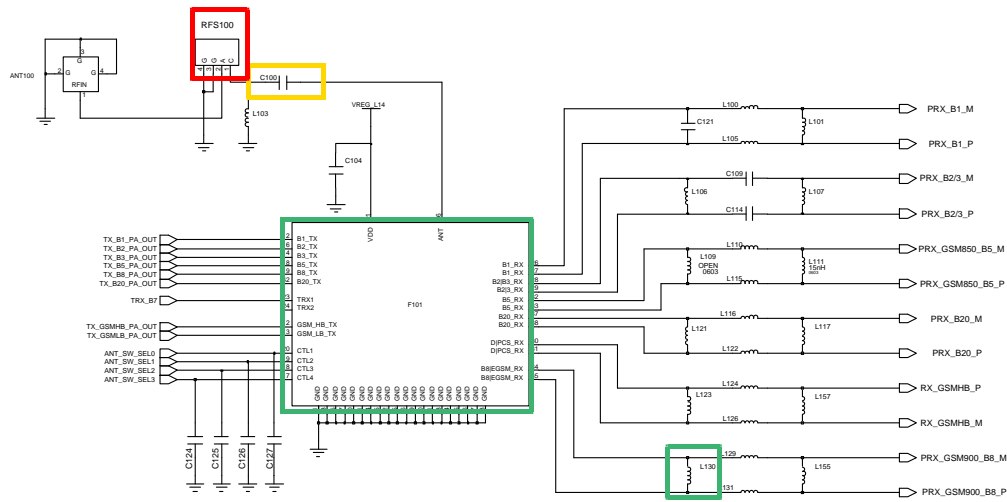

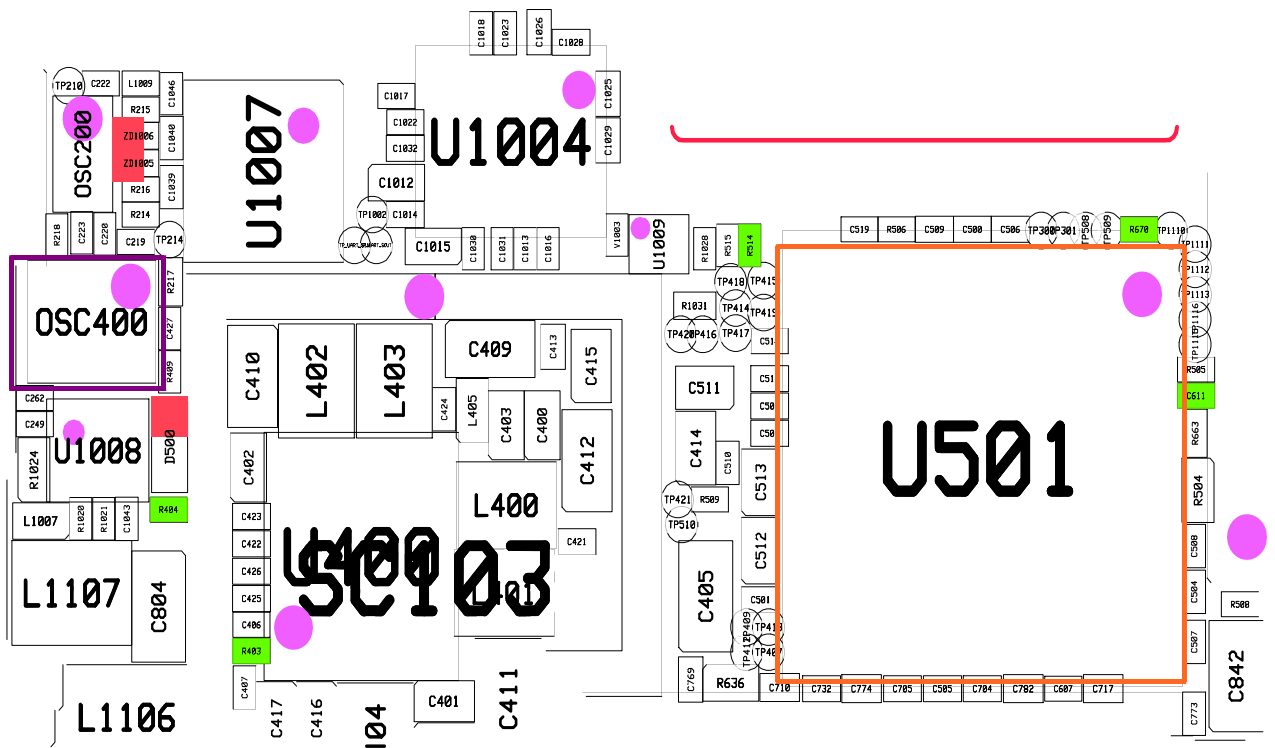
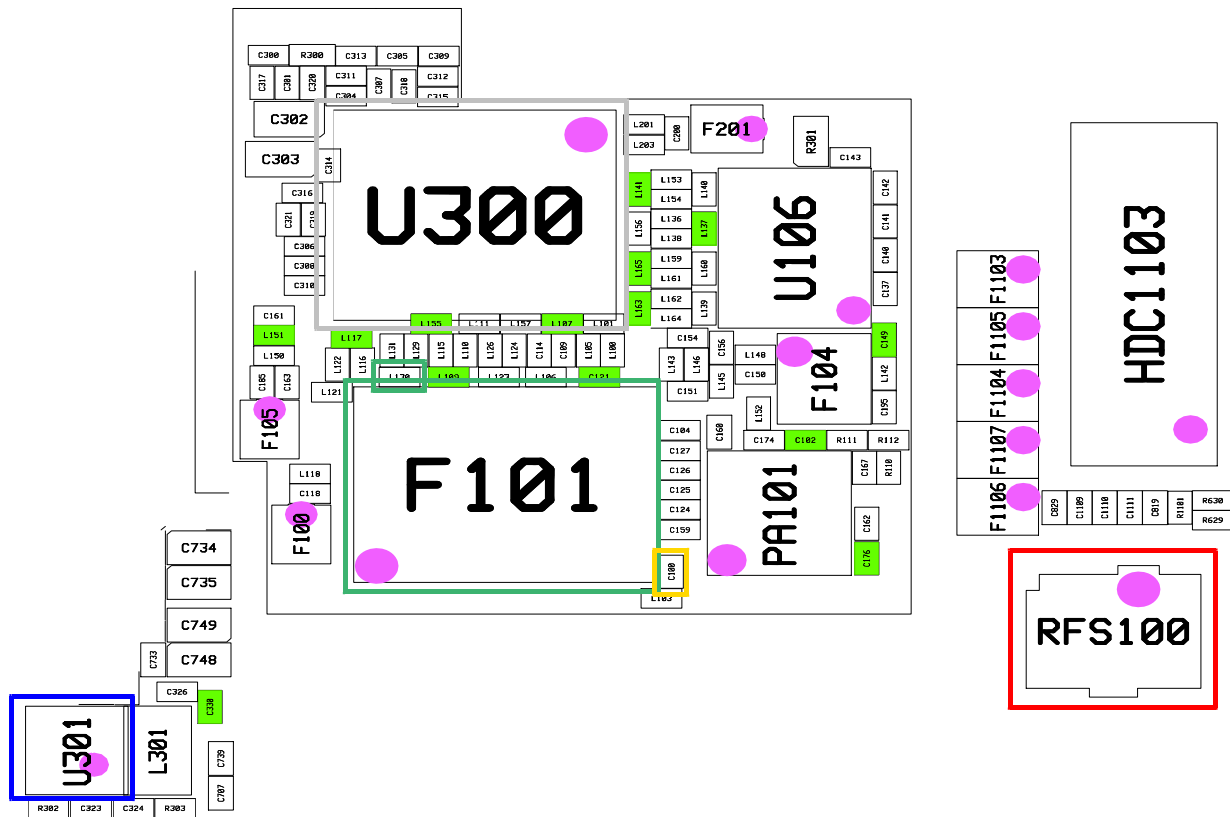

8-3-23. GSM1800/1900 RX

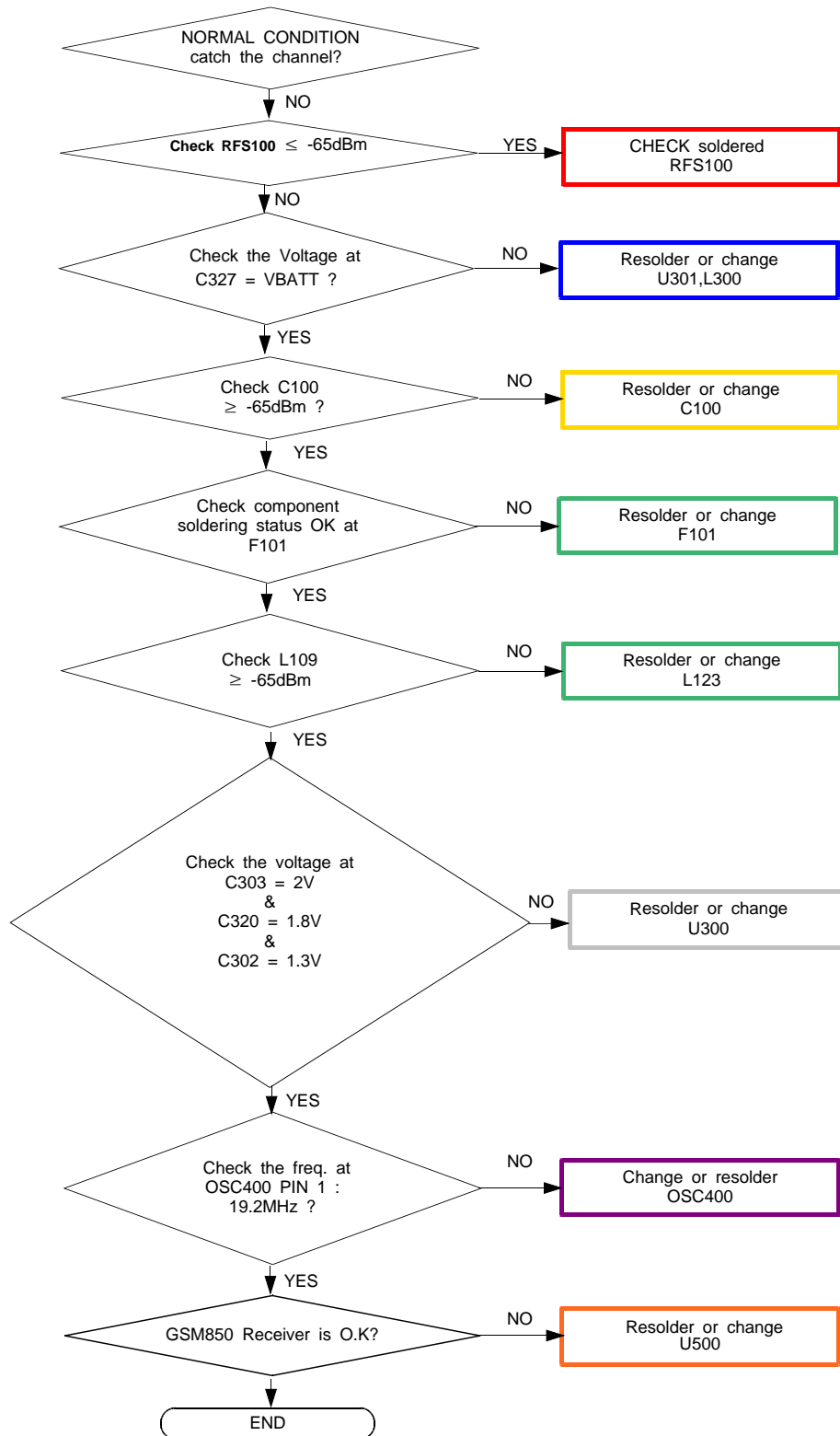

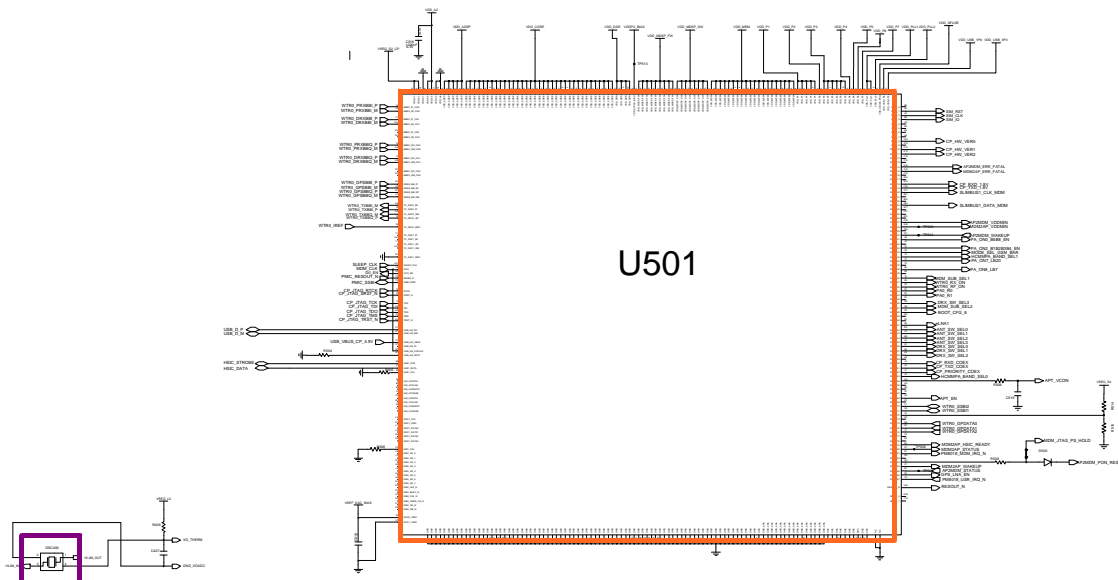
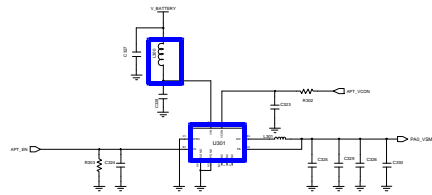
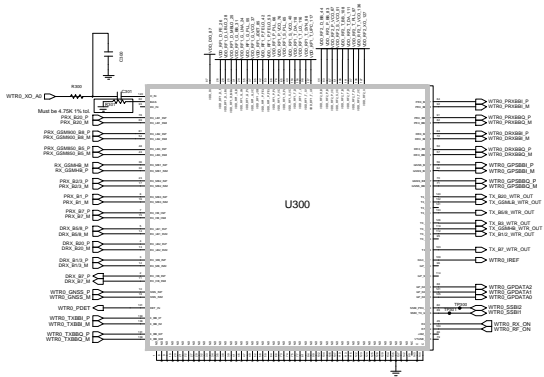
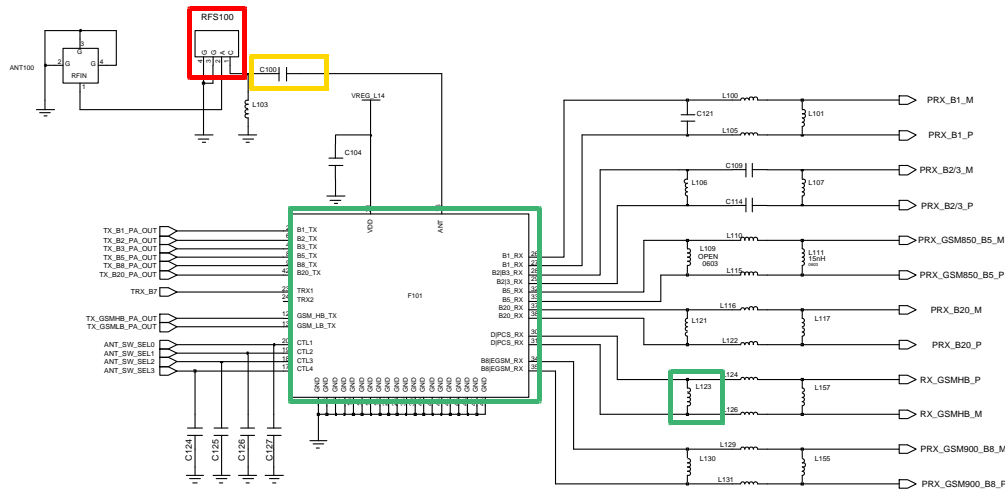

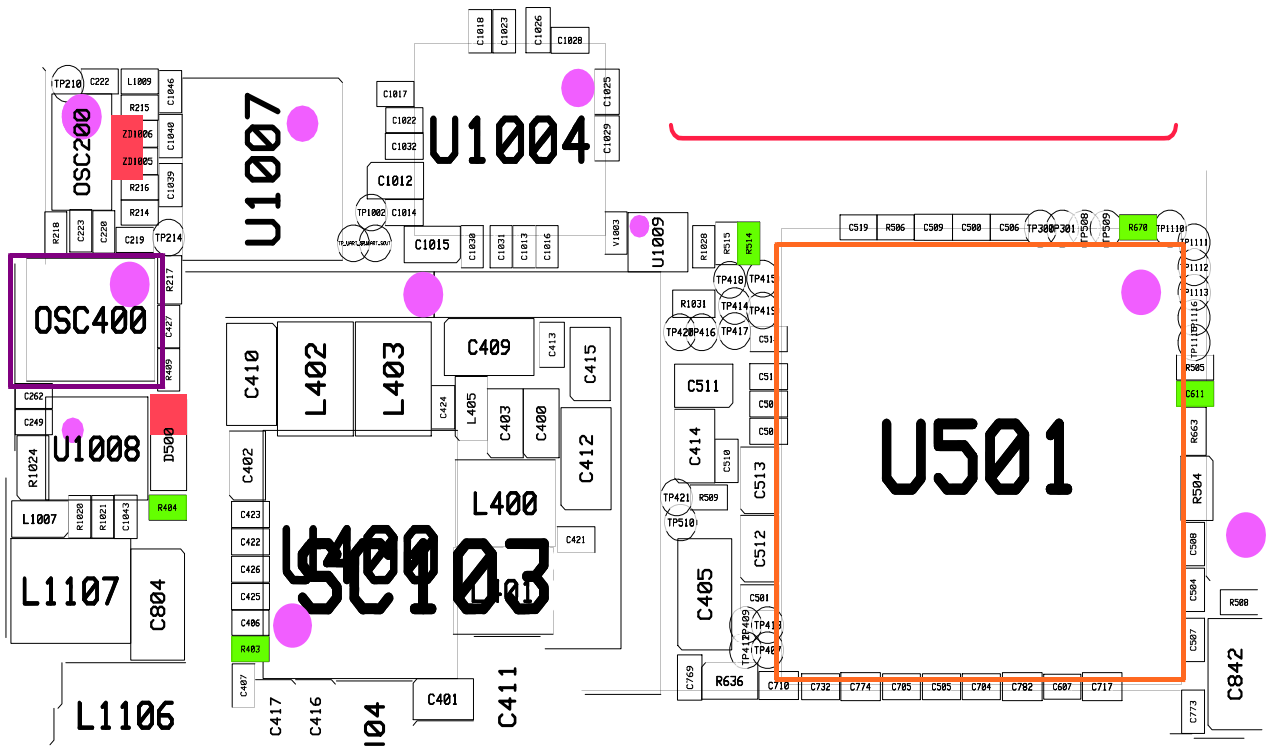
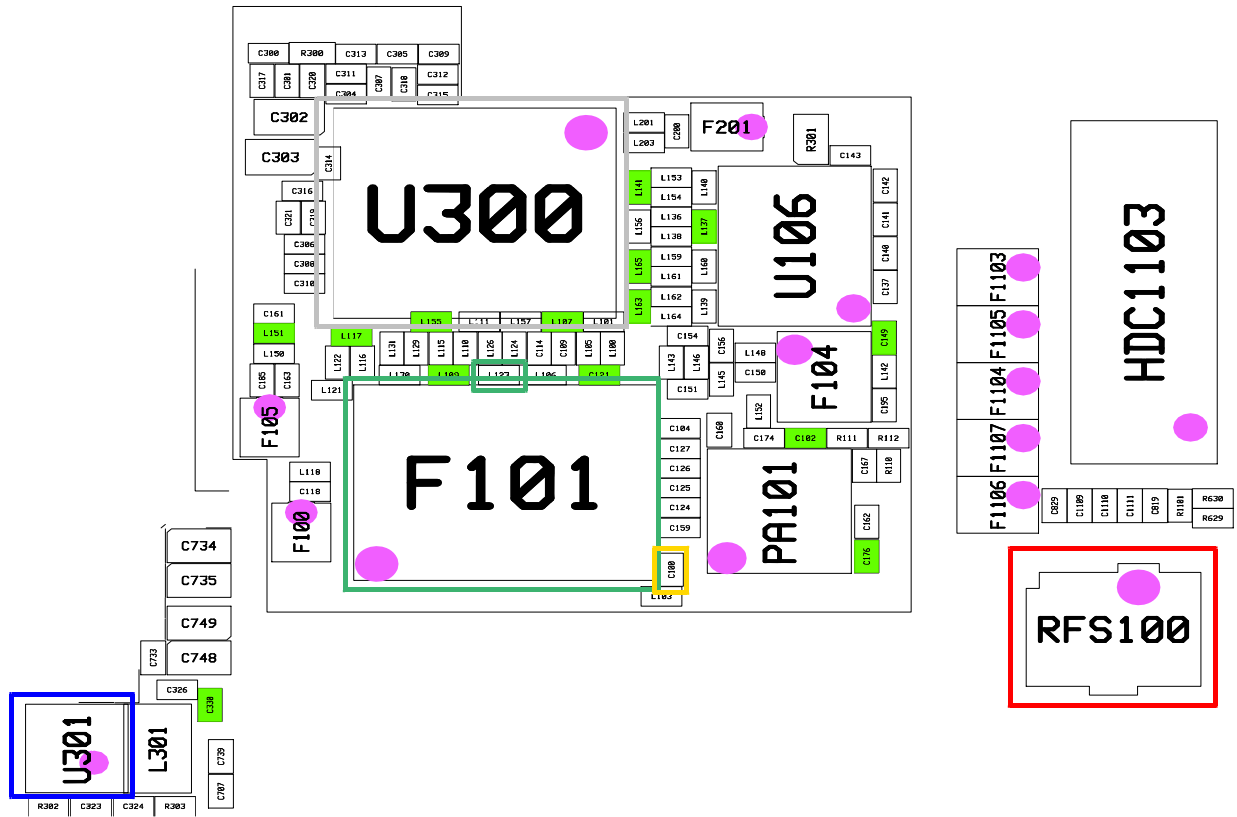

8-3-24. WCDMA2100 RX

CONTINUOUS RX ON
RF INPUT : 10700CH
AMP : -50dBm

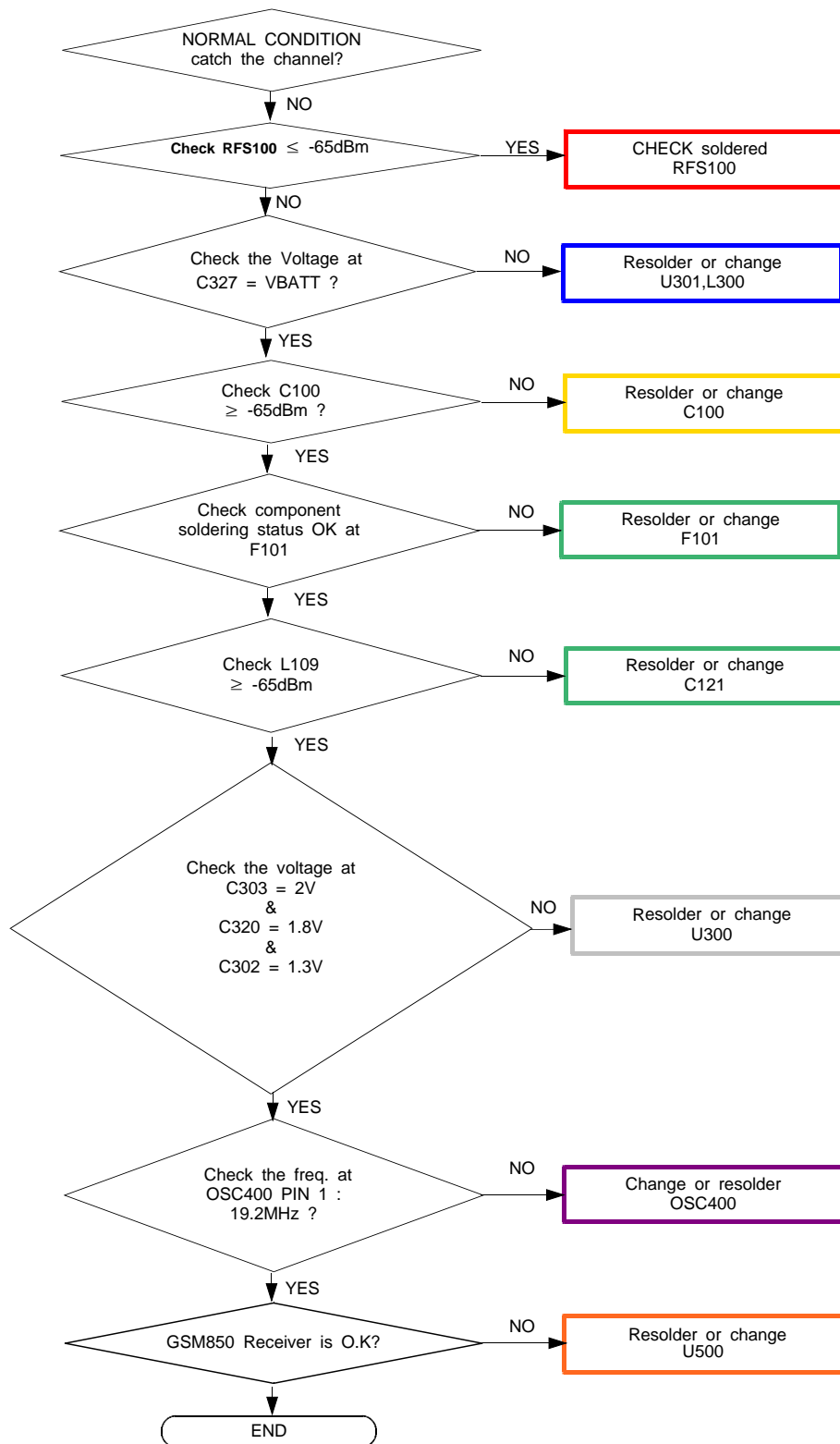

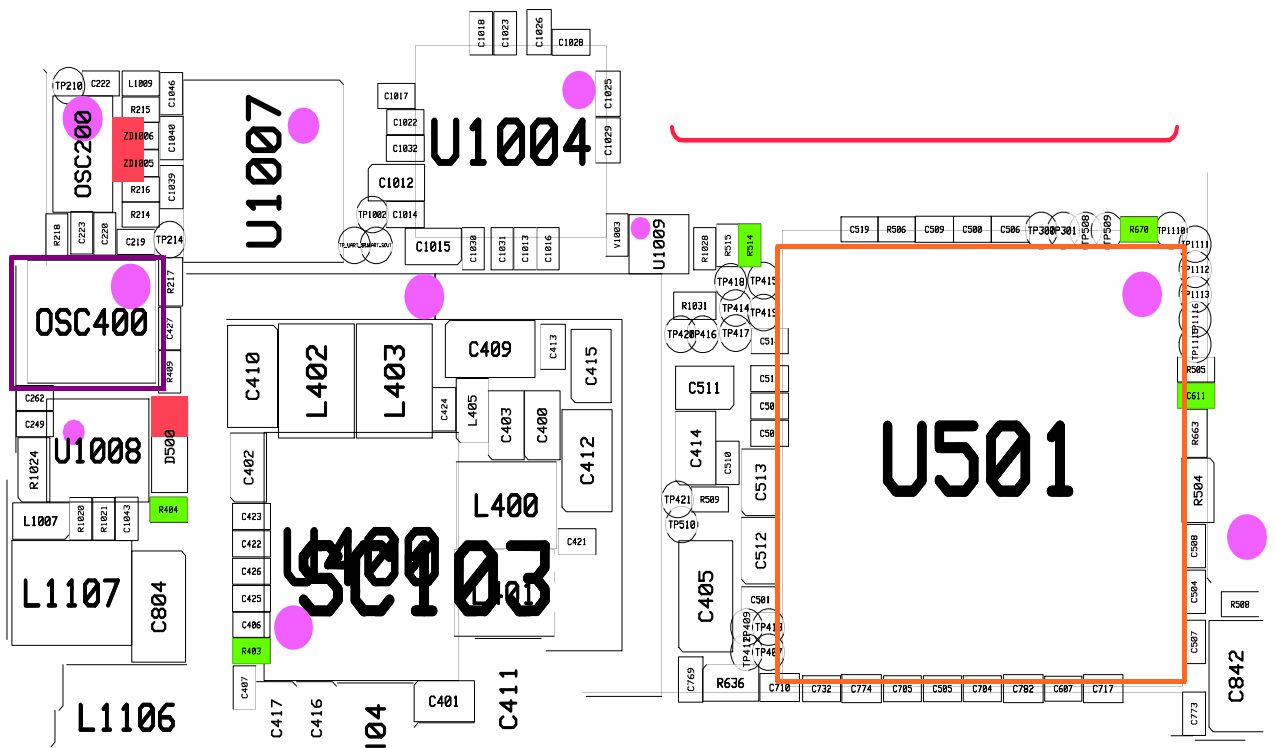
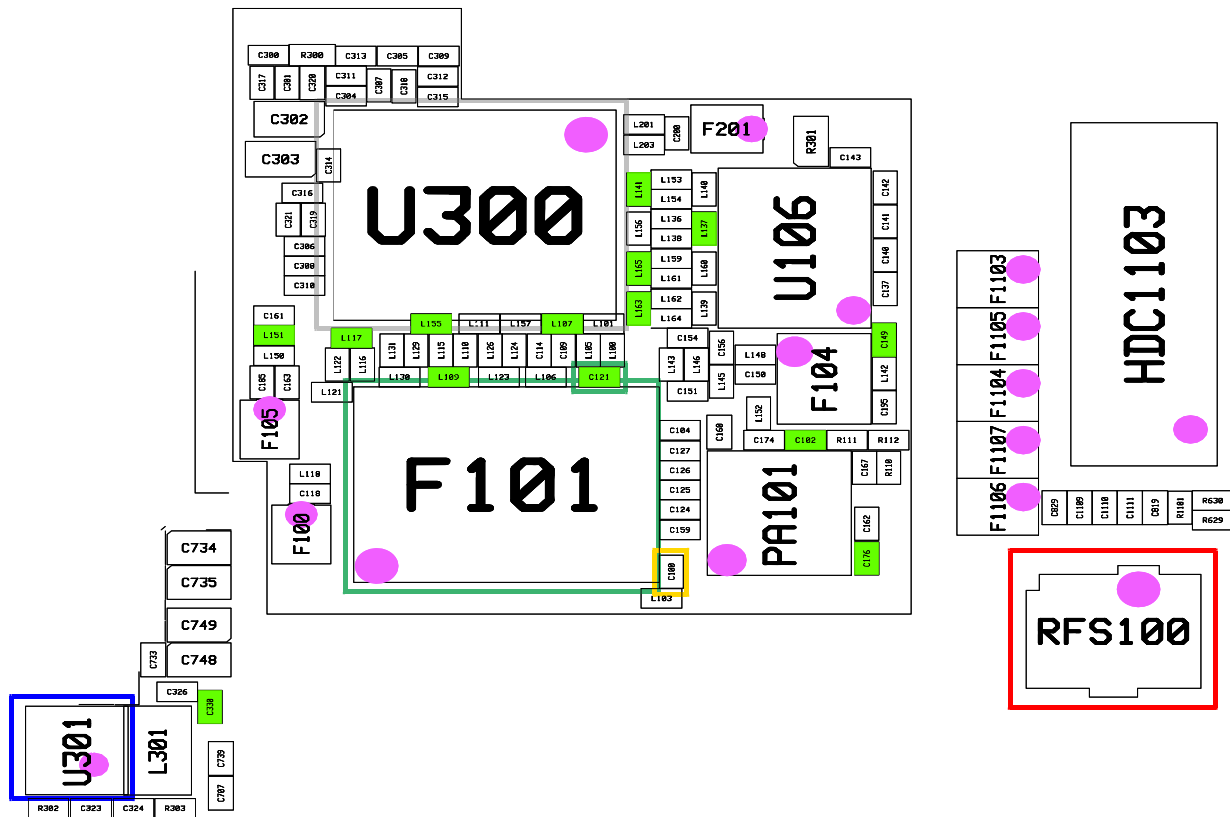

8-3-25. WCDMA1900 RX

CONTINUOUS RX ON
 RF INPUT : 9800CH
 AMP : -50dBm

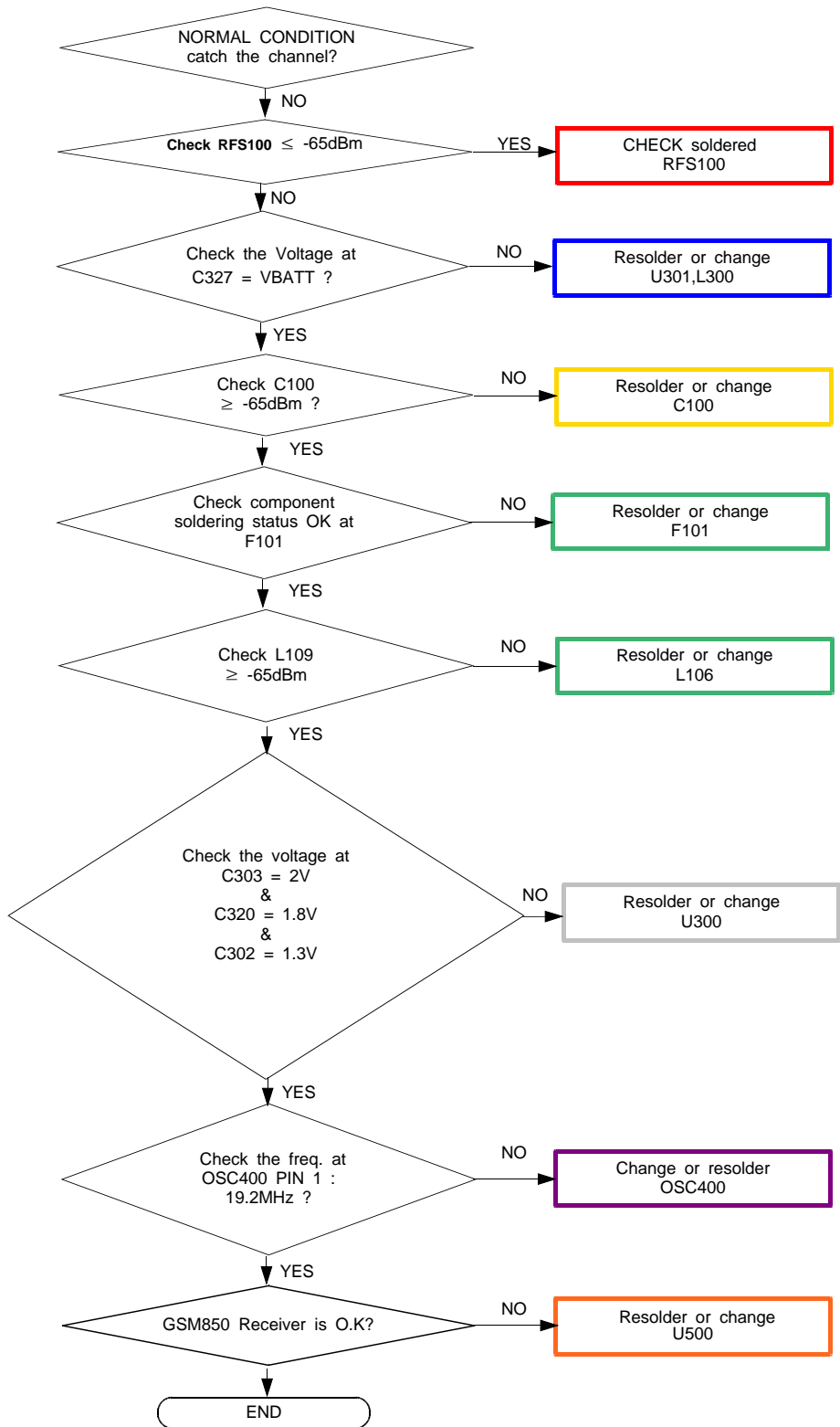

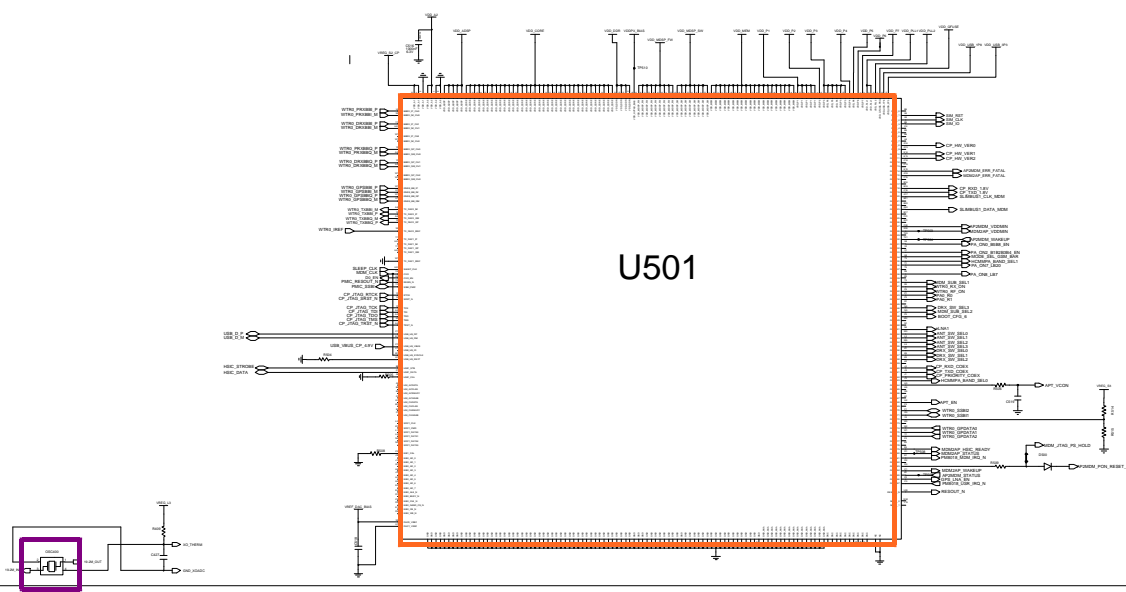
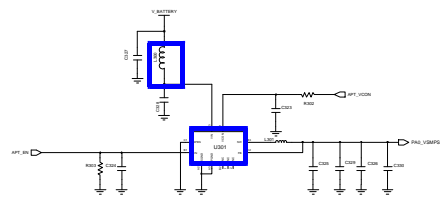
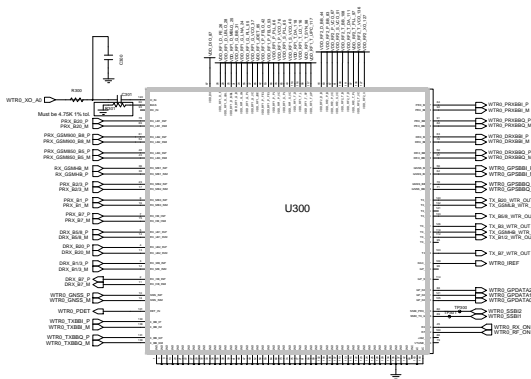
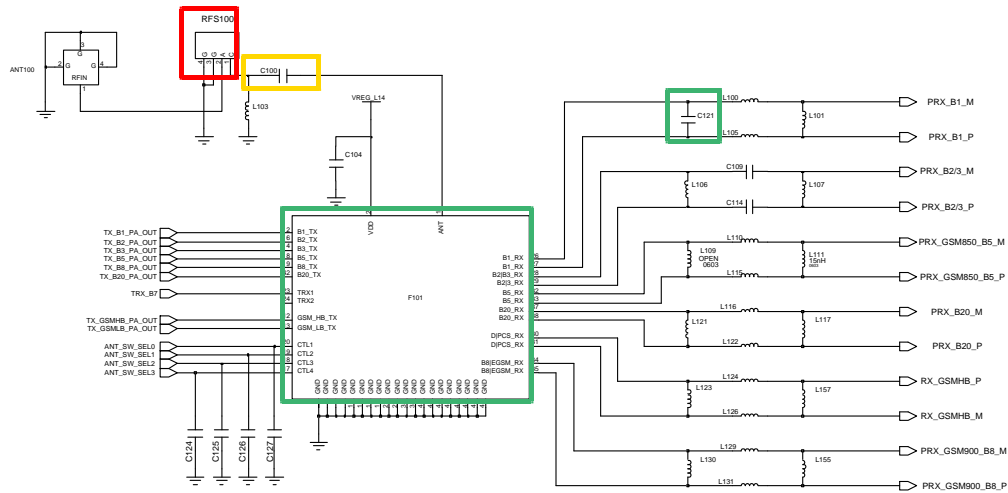

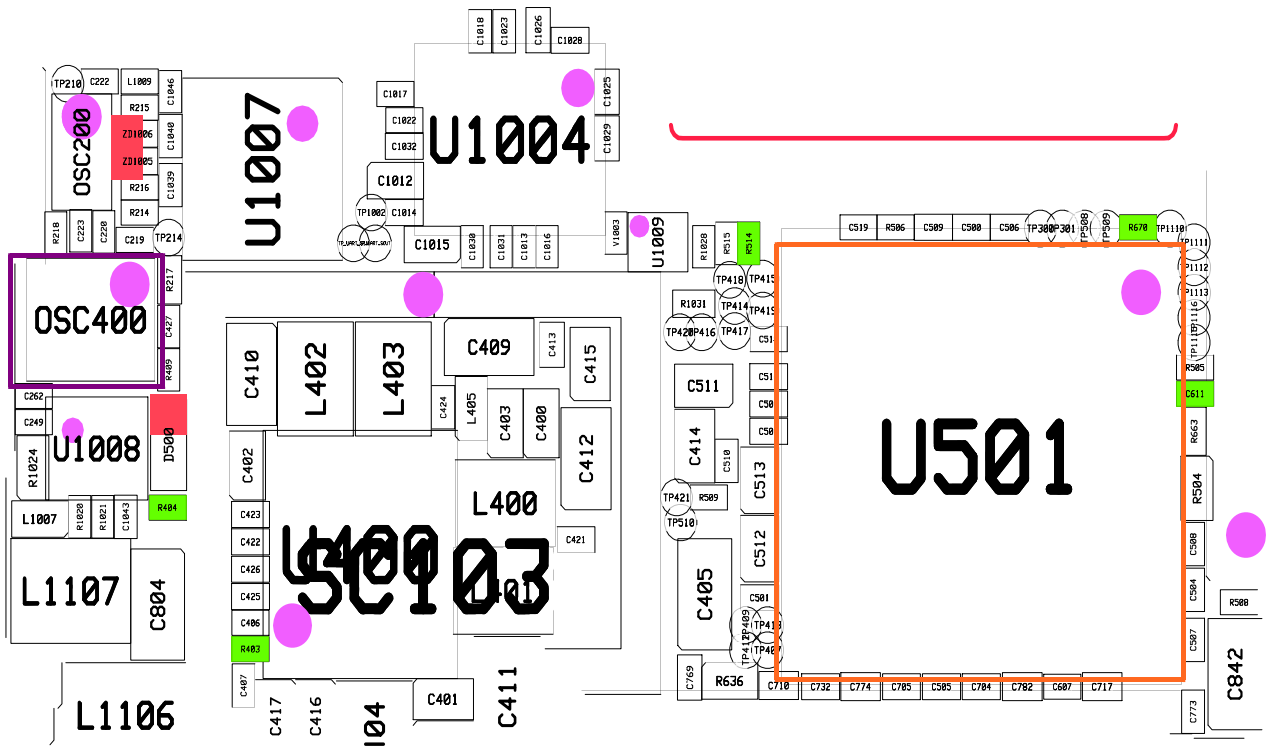
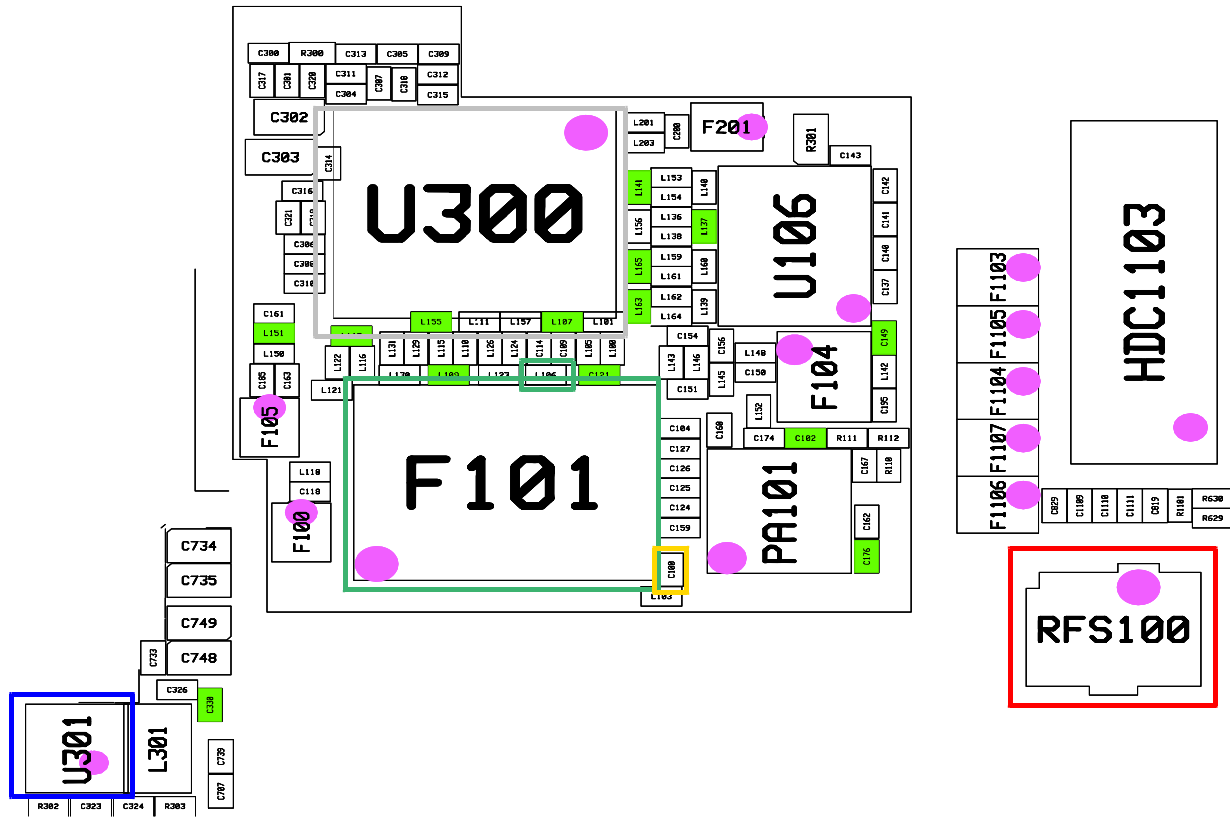

8-3-26. WCDMA850 RX

CONTINUOUS RX ON
RF INPUT : 4407CH
AMP : -50dBm

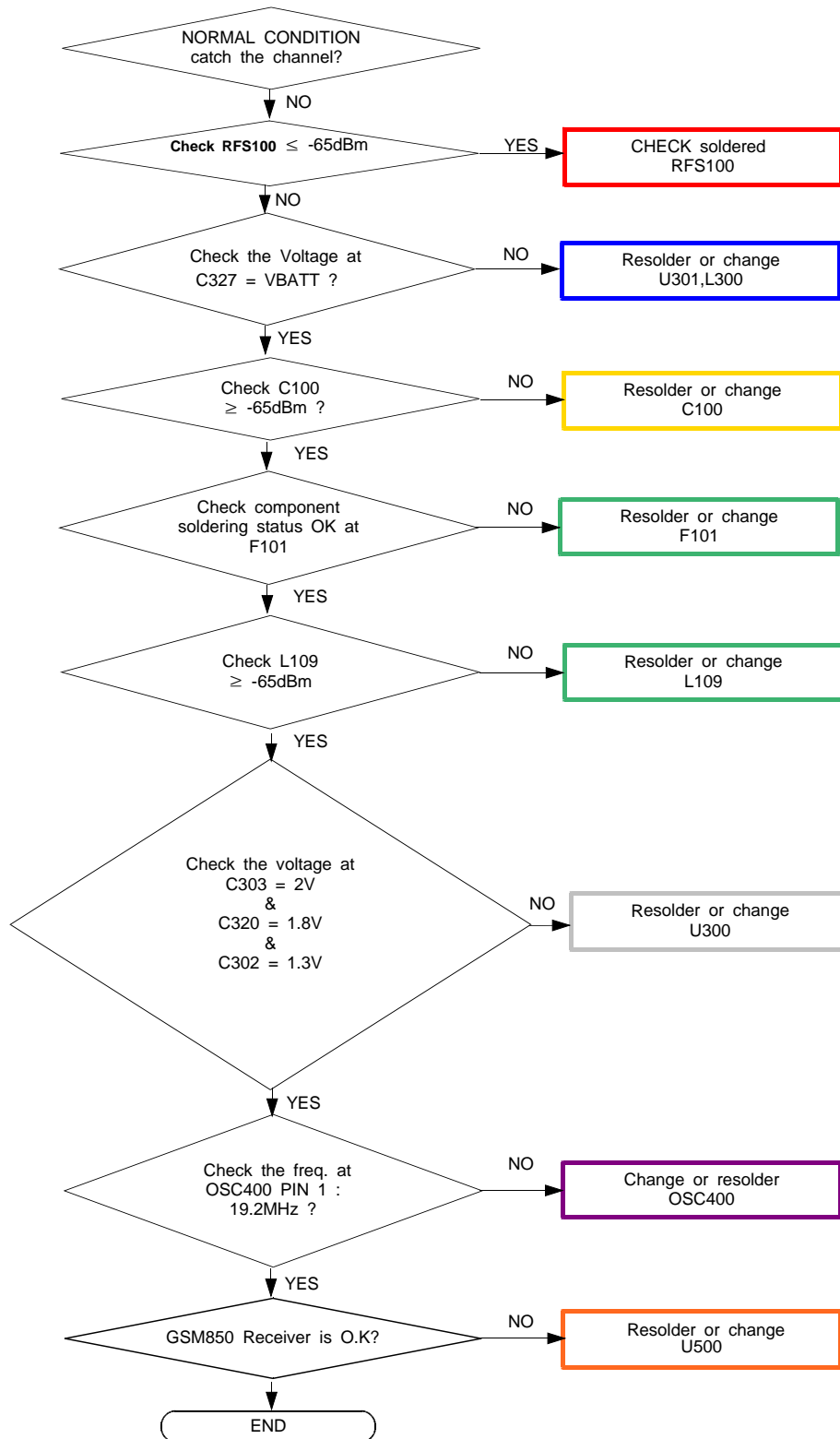

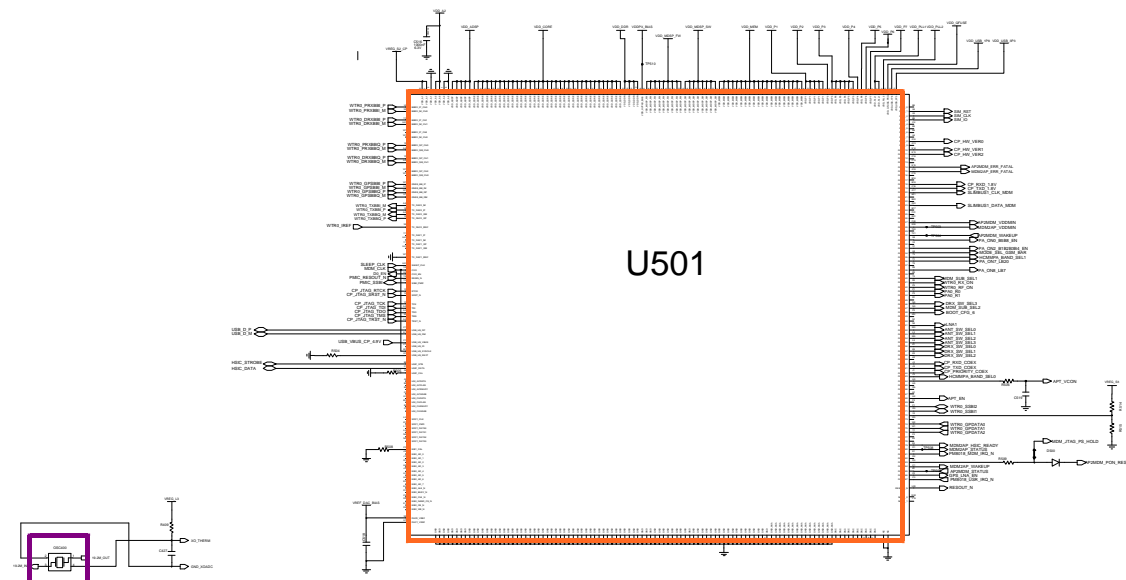
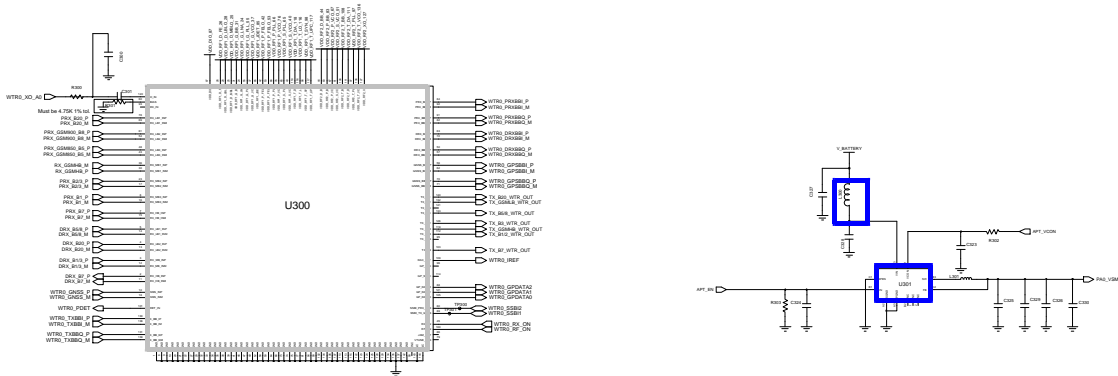
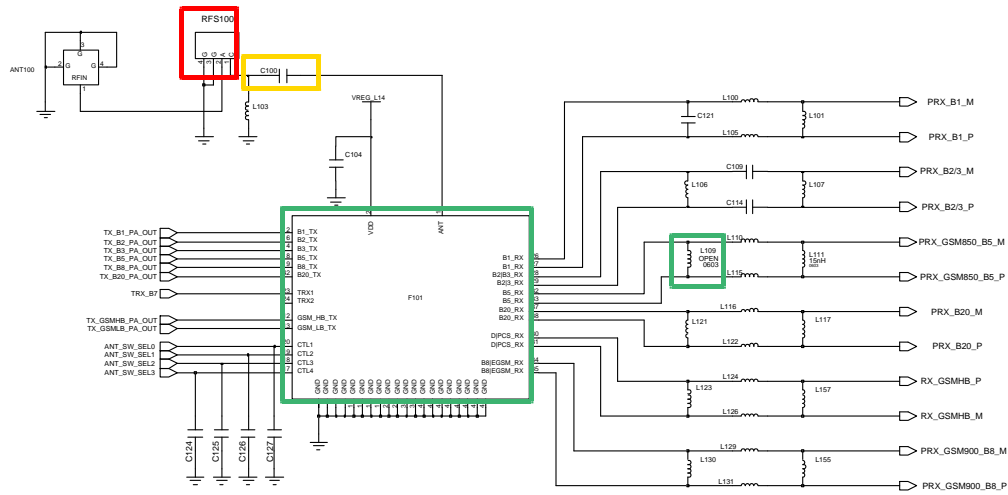

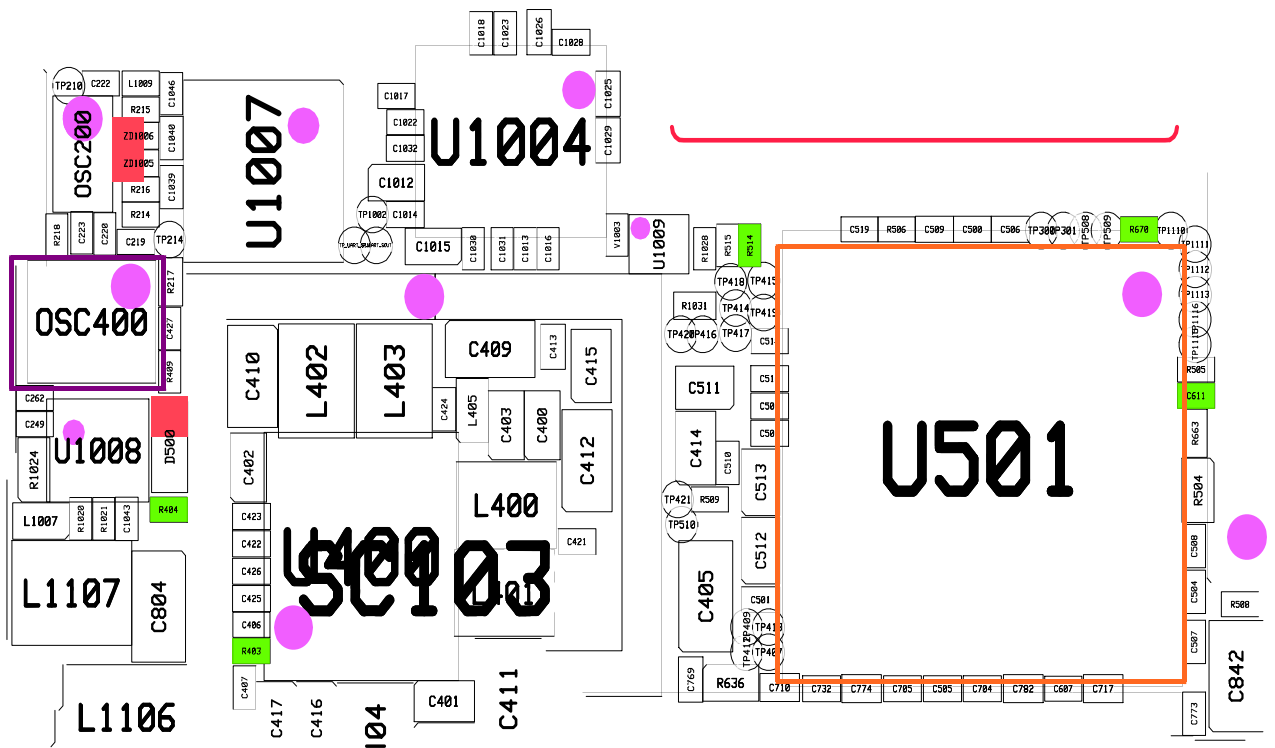
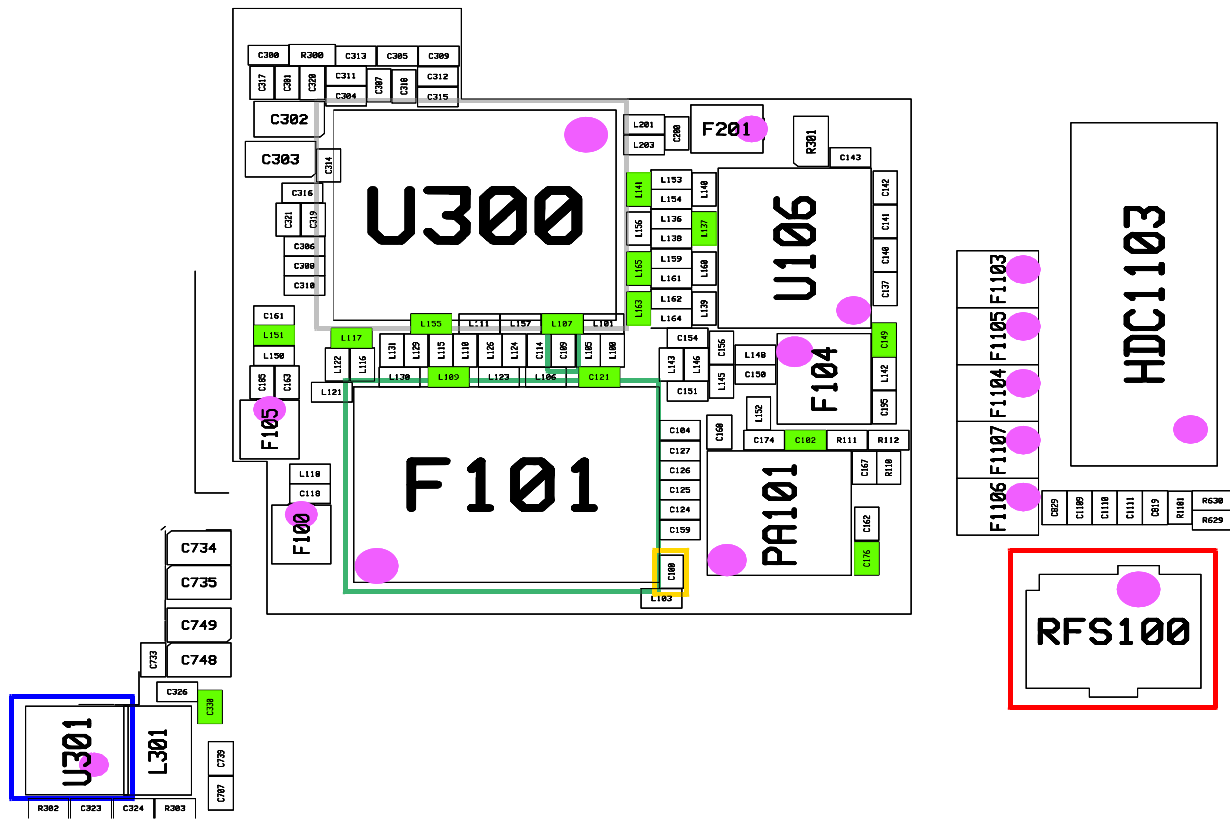

8-3-27. WCDMA900 RX

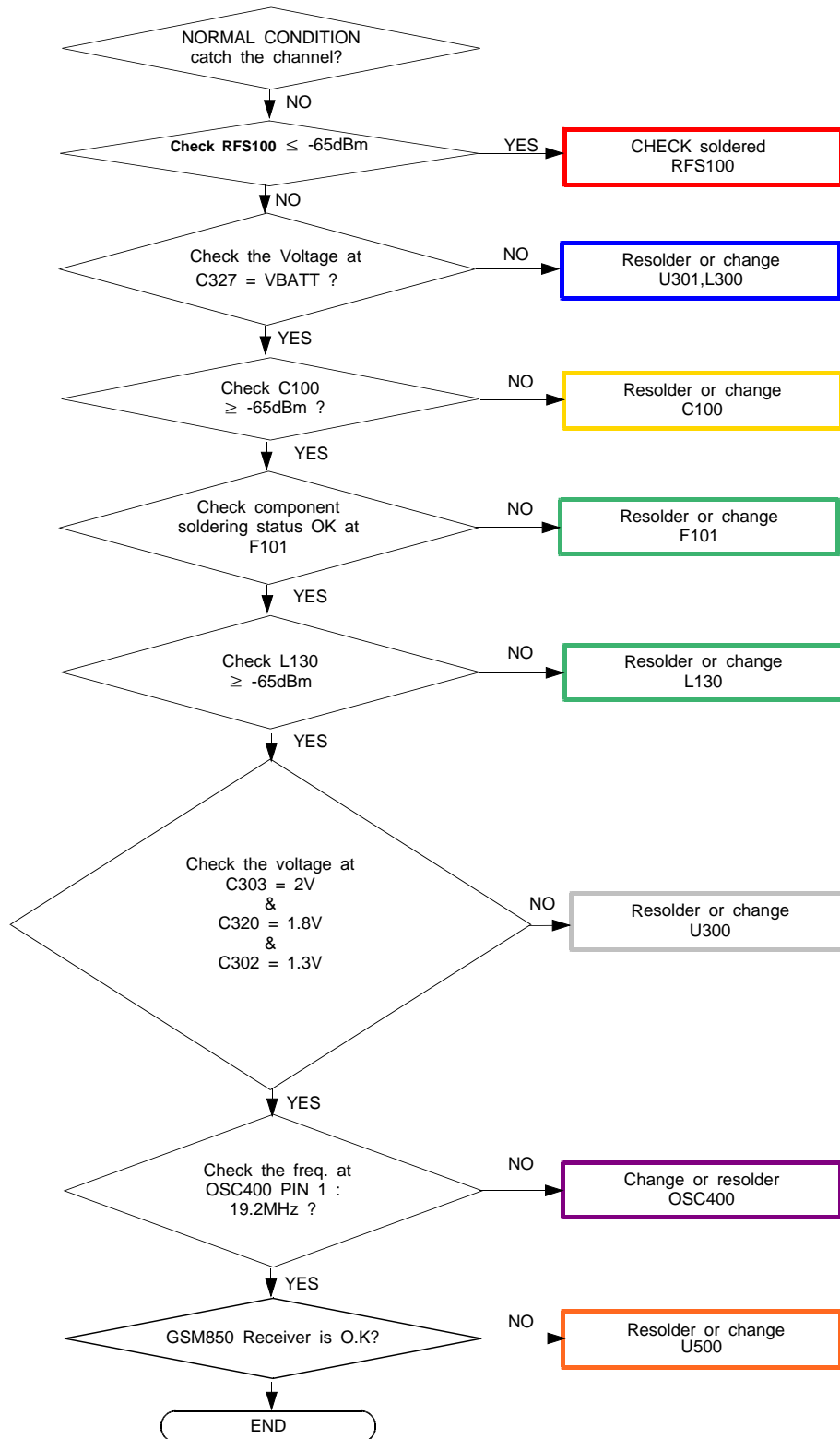

CONTINUOUS RX ON
RF INPUT : 3013CH
AMP : -50dBm

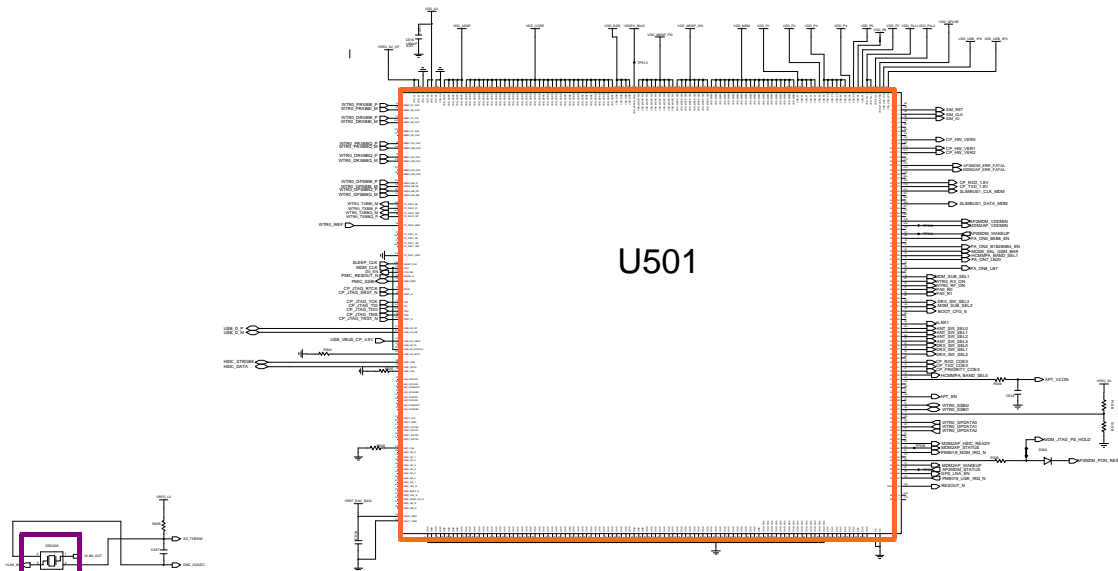
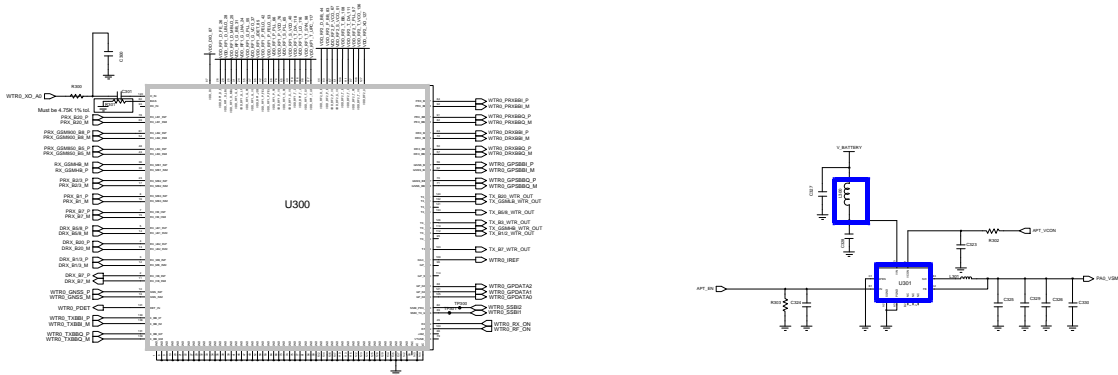
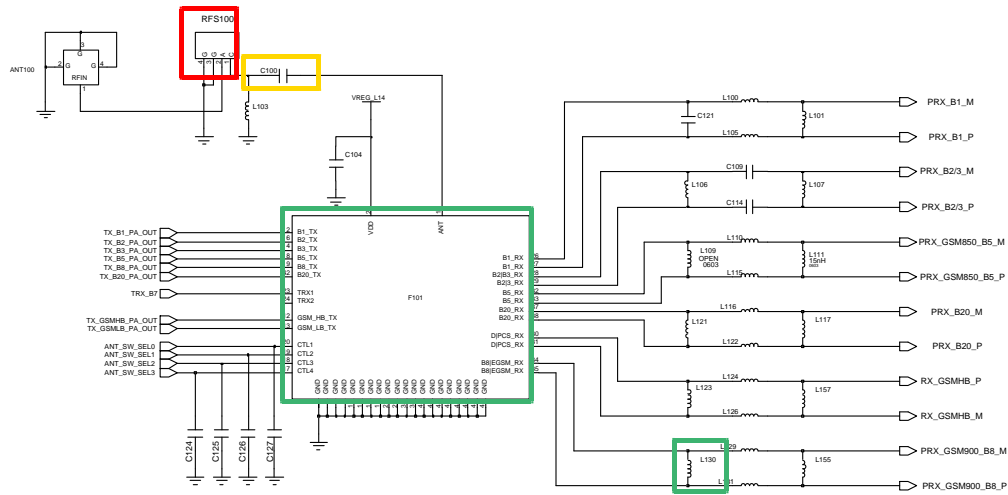

8-3-28. LTE B1 RX

CONTINUOUS RX ON
 RF INPUT : 300CH
 AMP : -50dBm

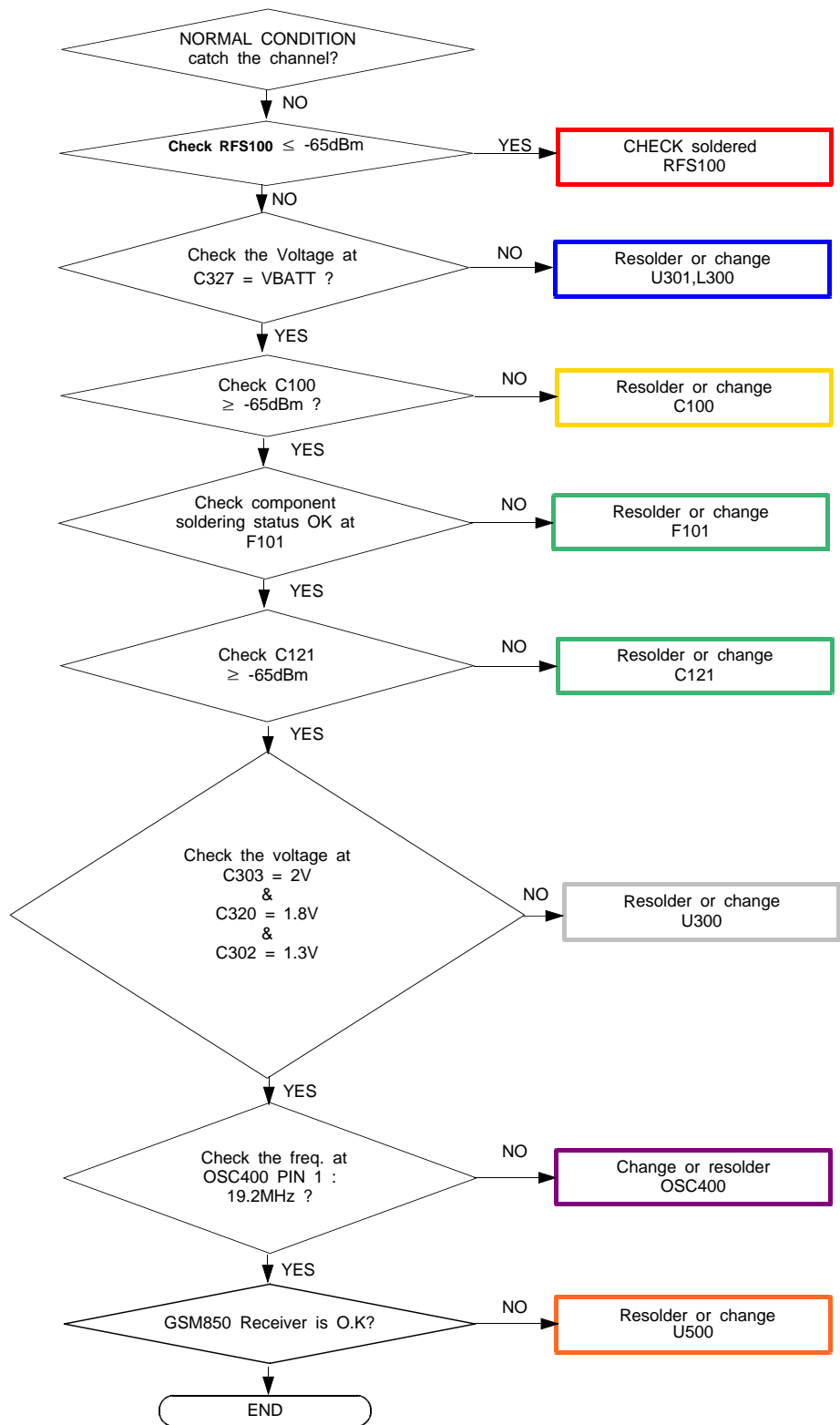

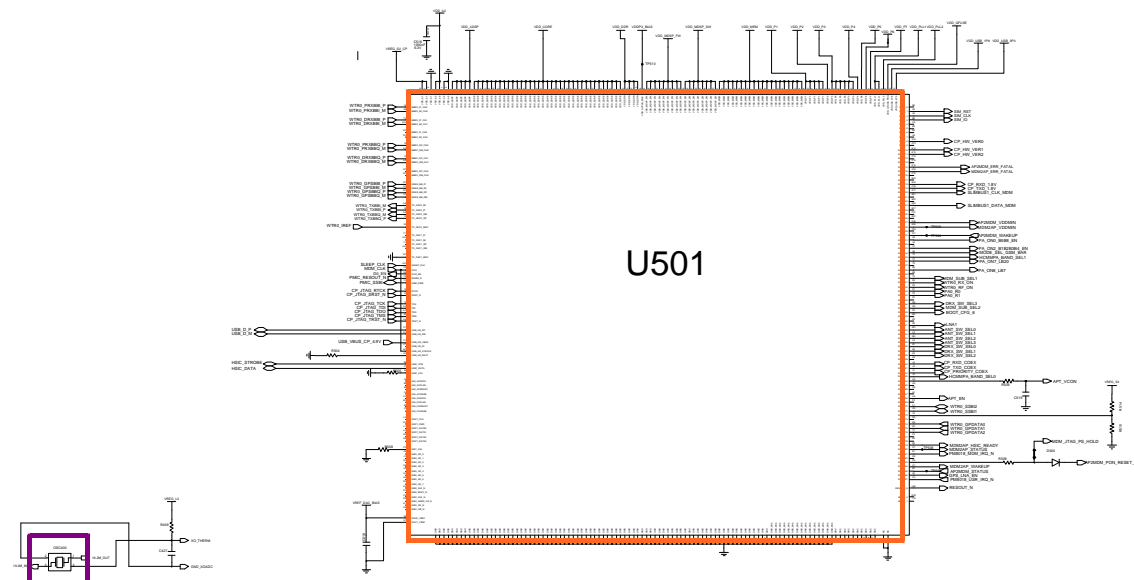
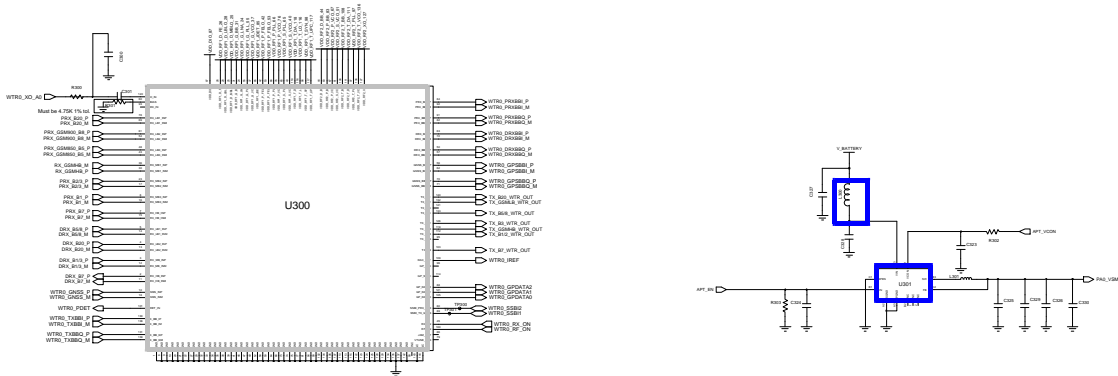
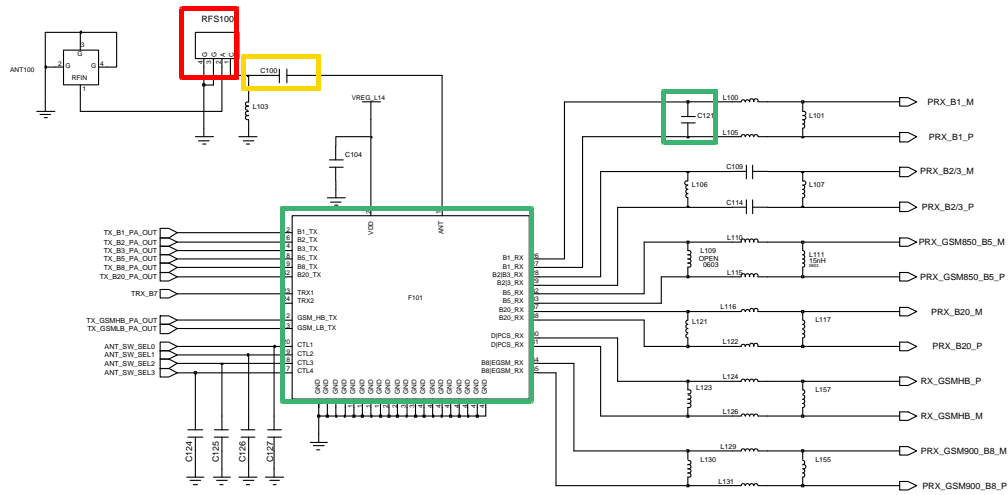

8-3-29. LTE B3 RX

CONTINUOUS RX ON
RF INPUT : 1575CH
AMP : -50dBm

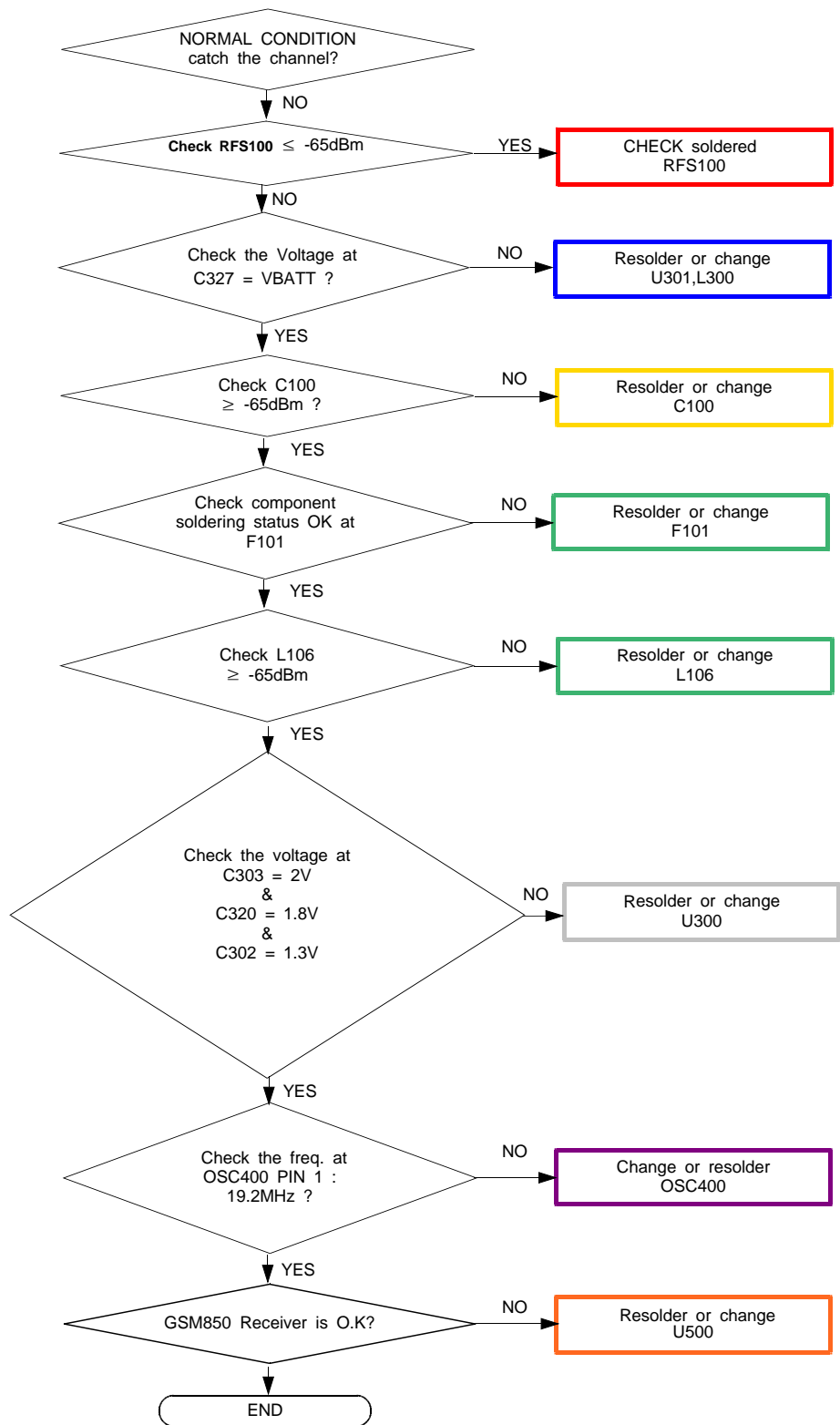

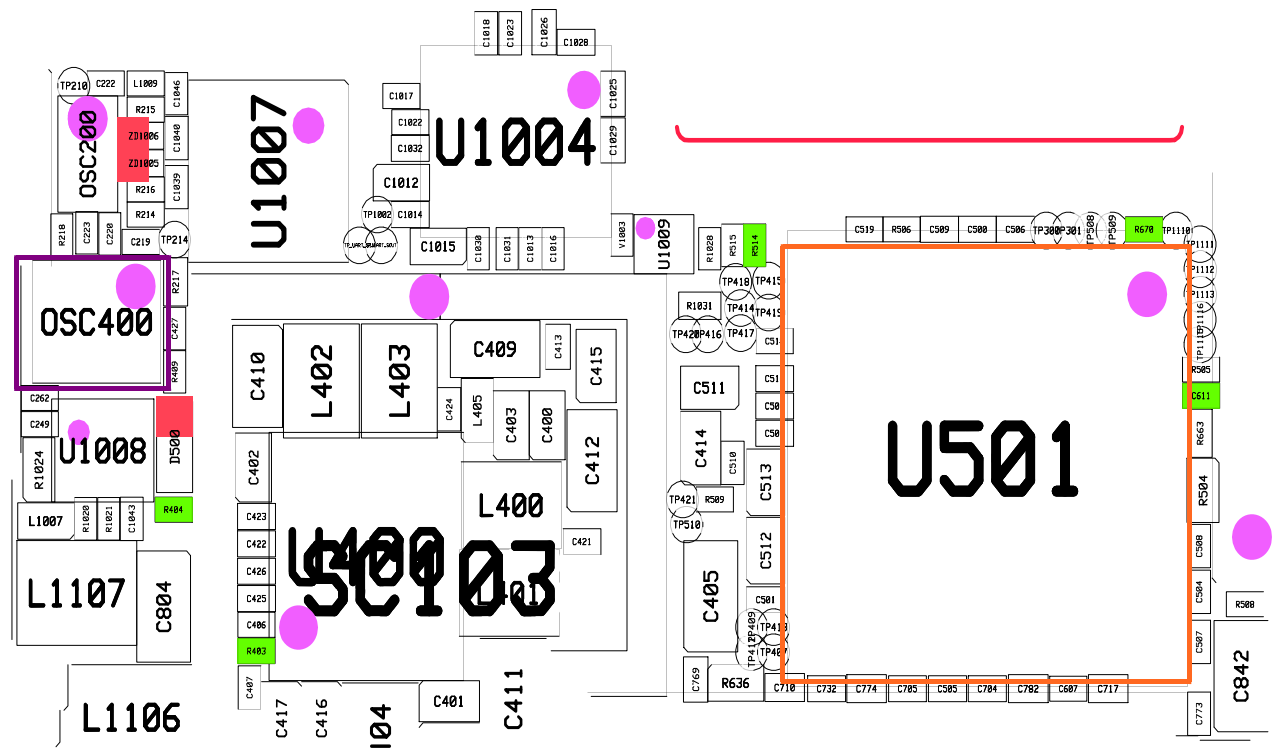
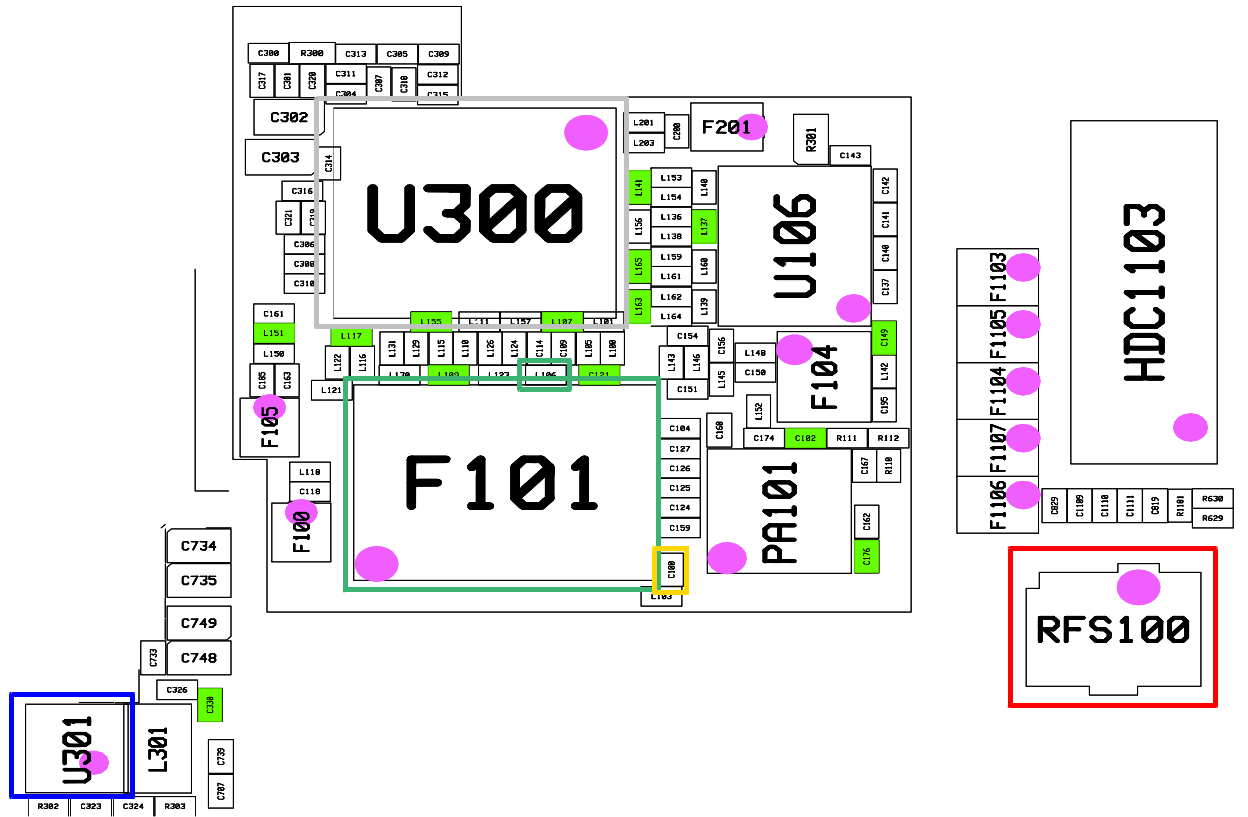

8-3-30. LTE B5 RX

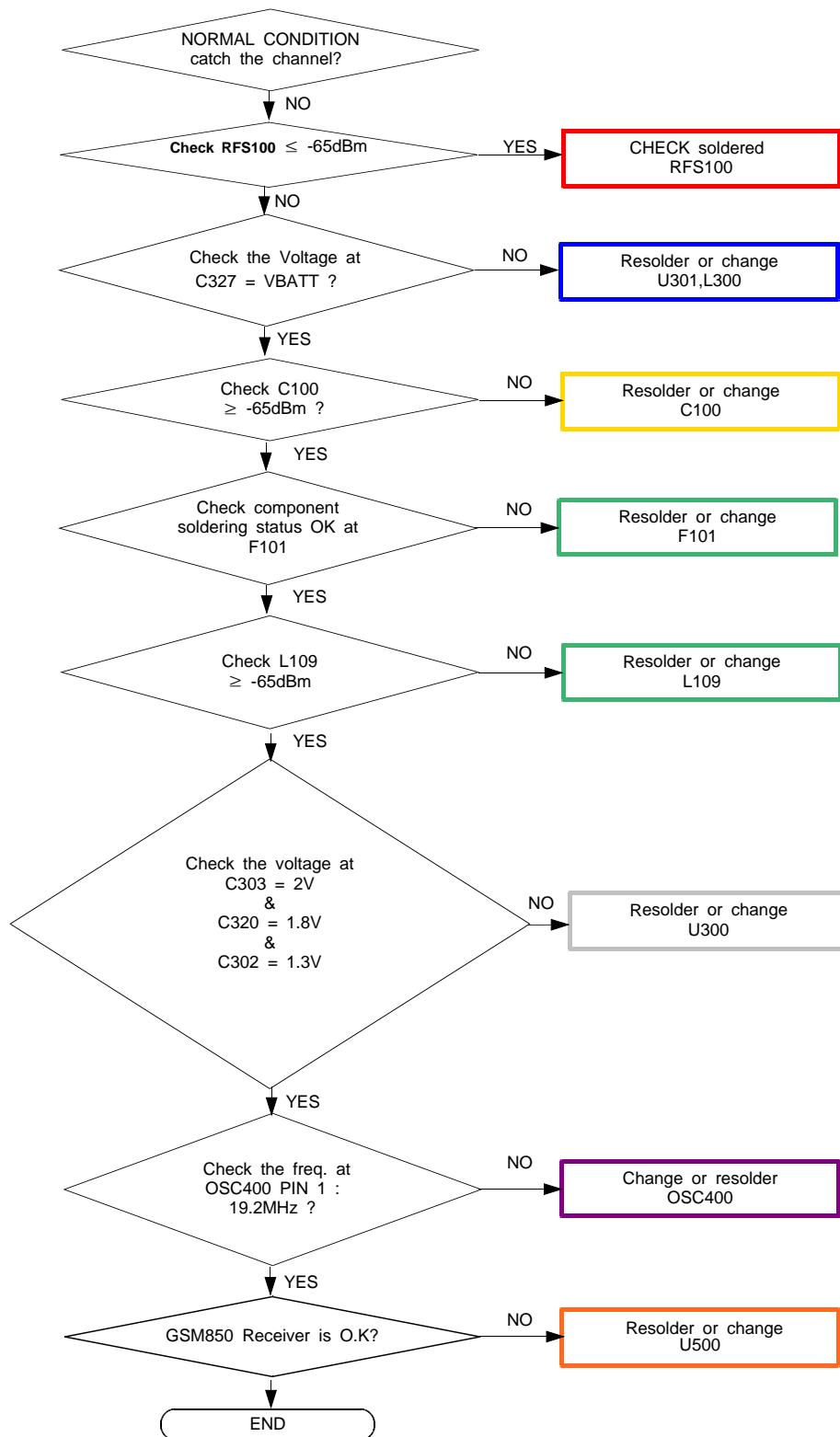

CONTINUOUS RX ON
RF INPUT : 2525CH
AMP : -50dBm

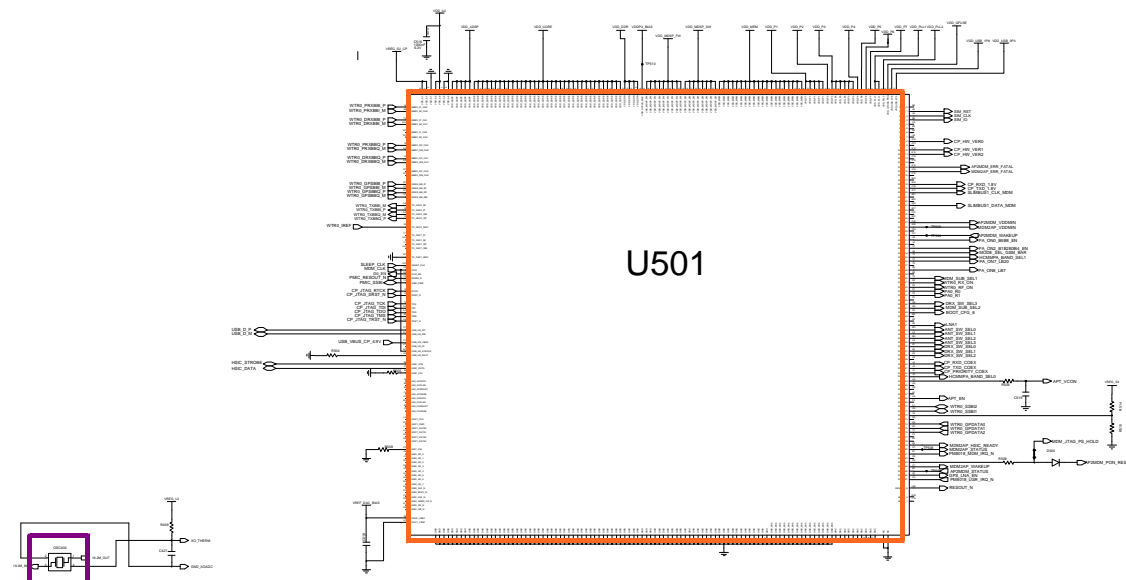
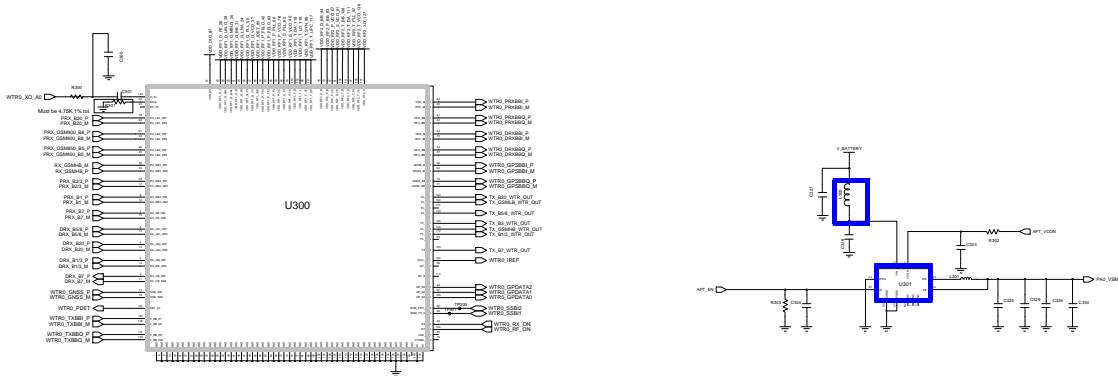
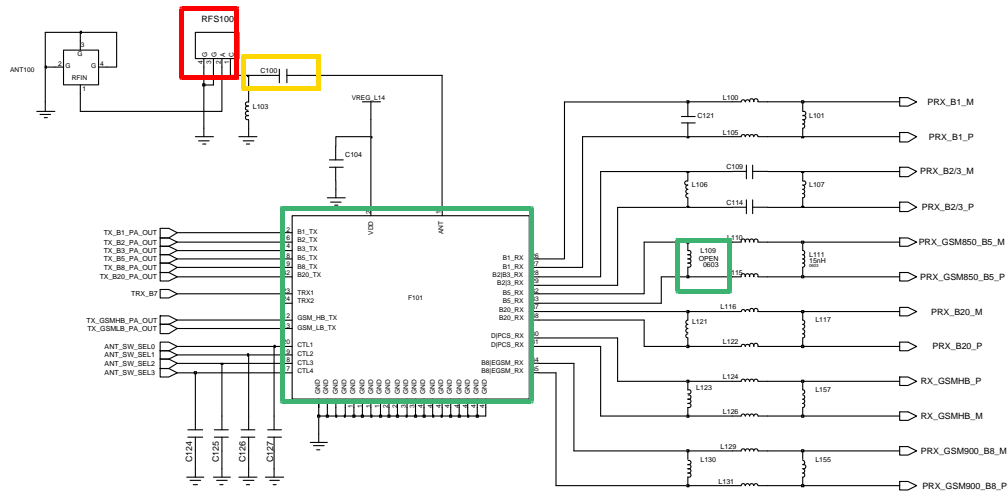

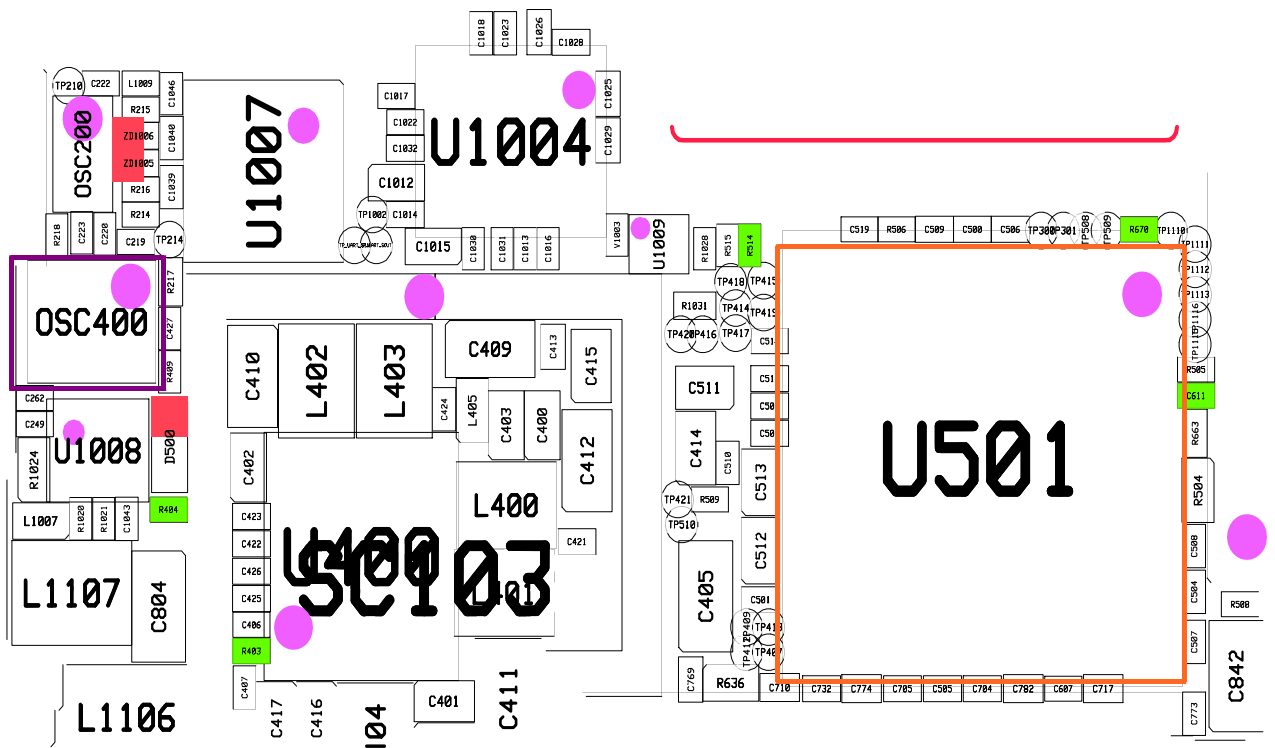
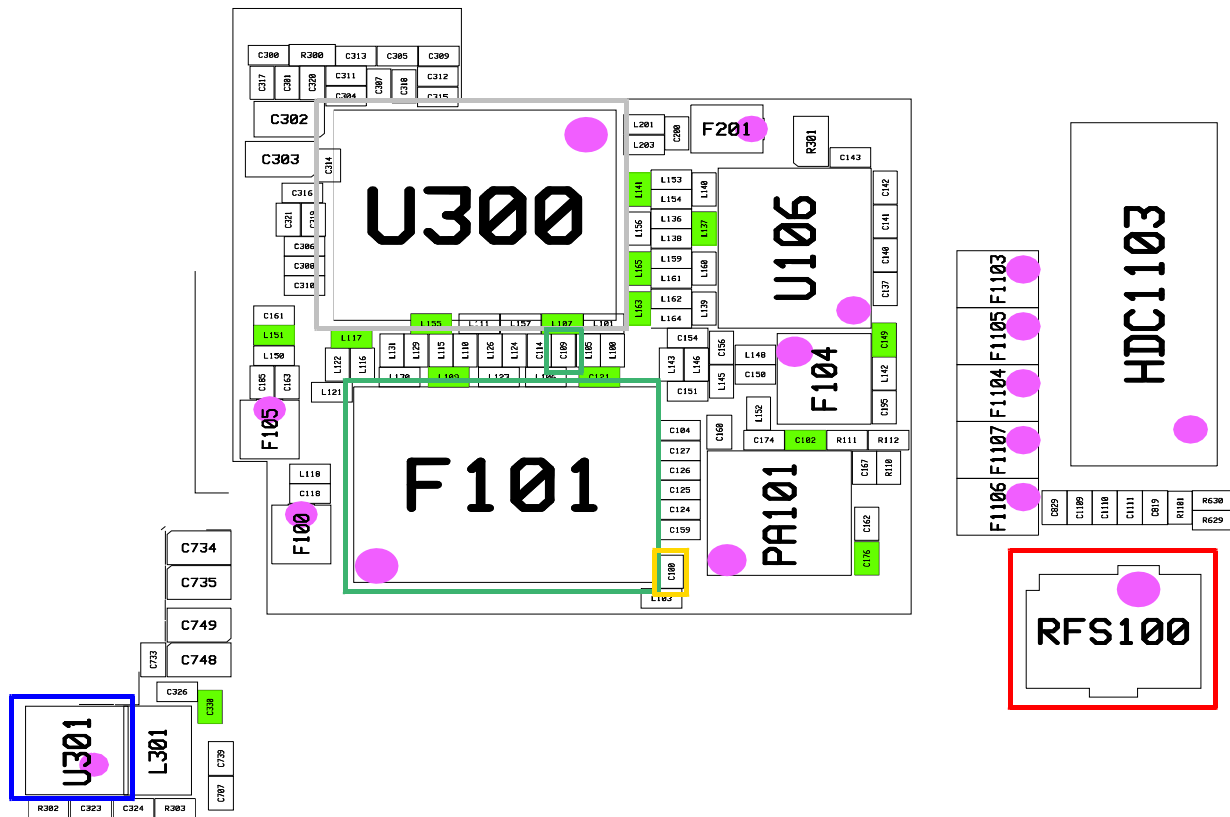

8-3-31. LTE B8 RX

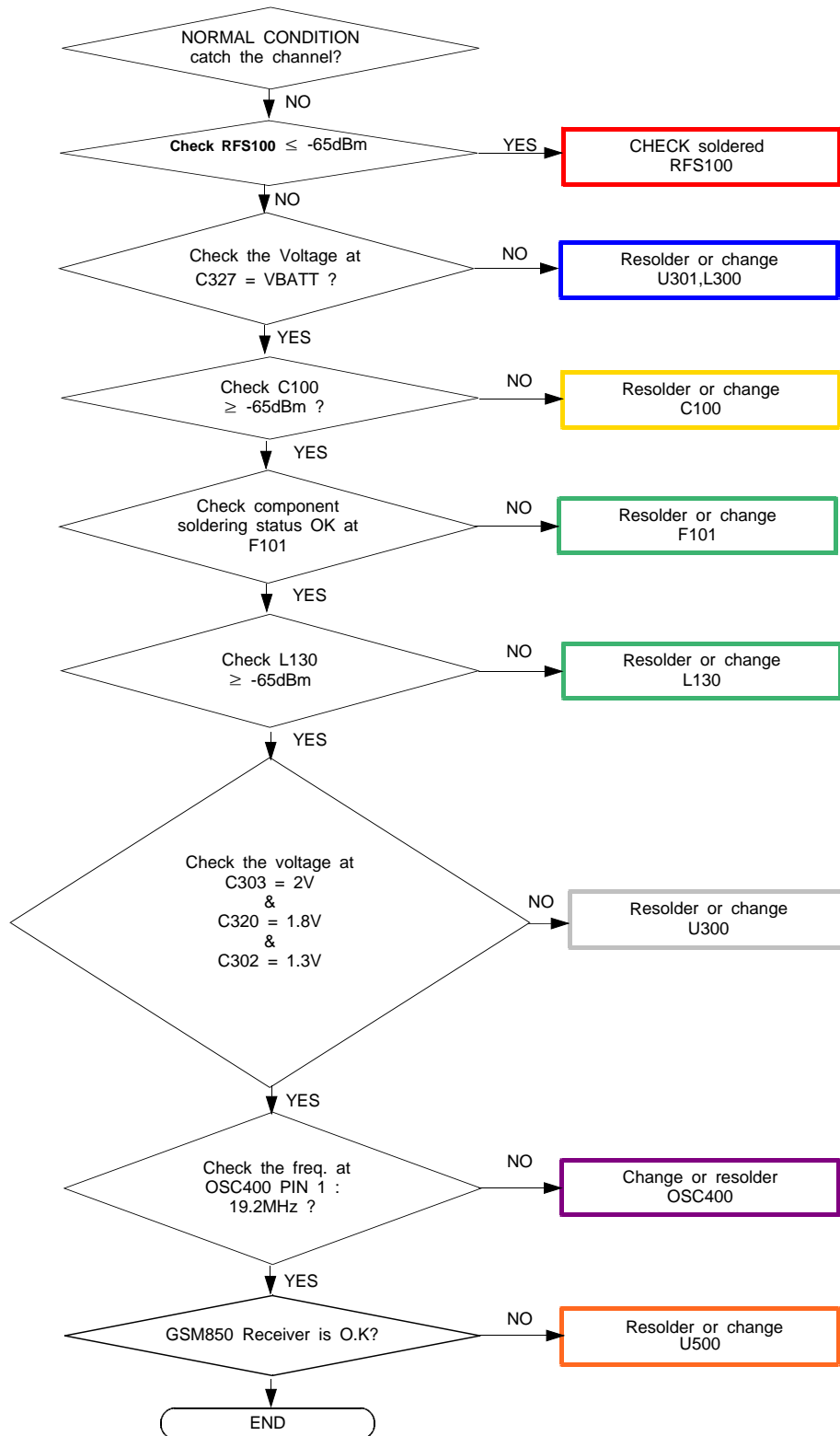

CONTINUOUS RX ON
RF INPUT : 3625CH
AMP : -50dBm

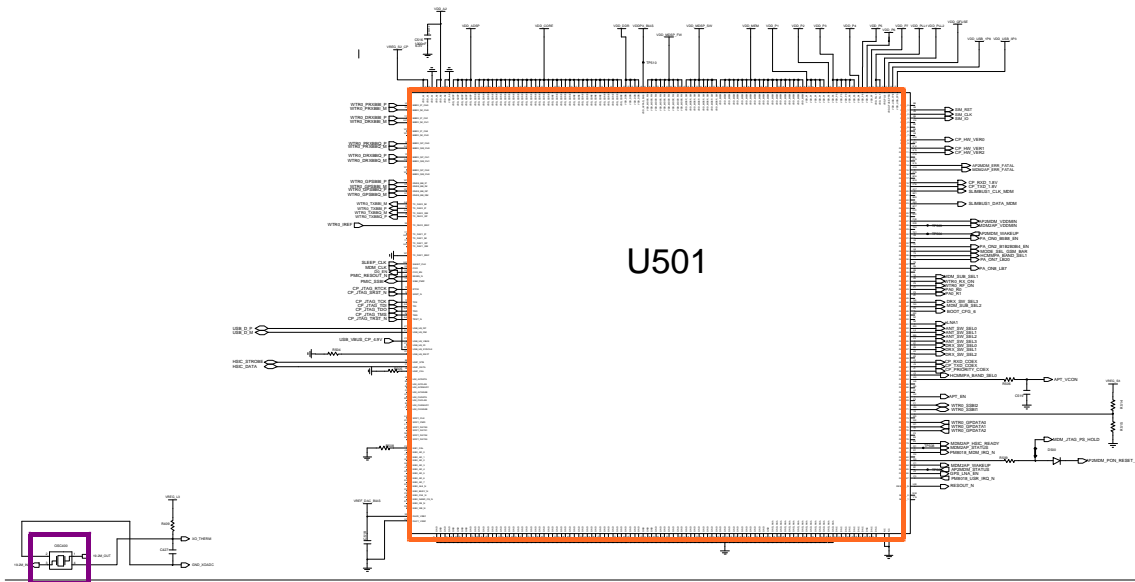
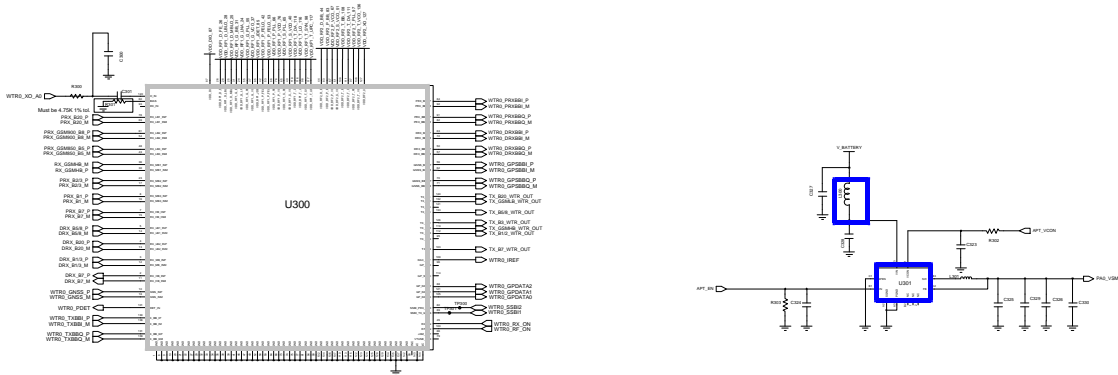
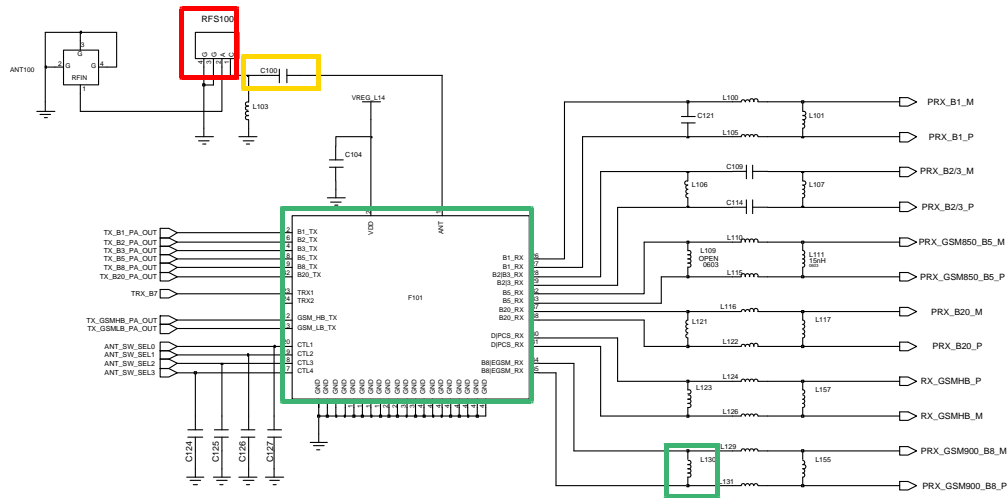

8-3-32. LTE B7 RX

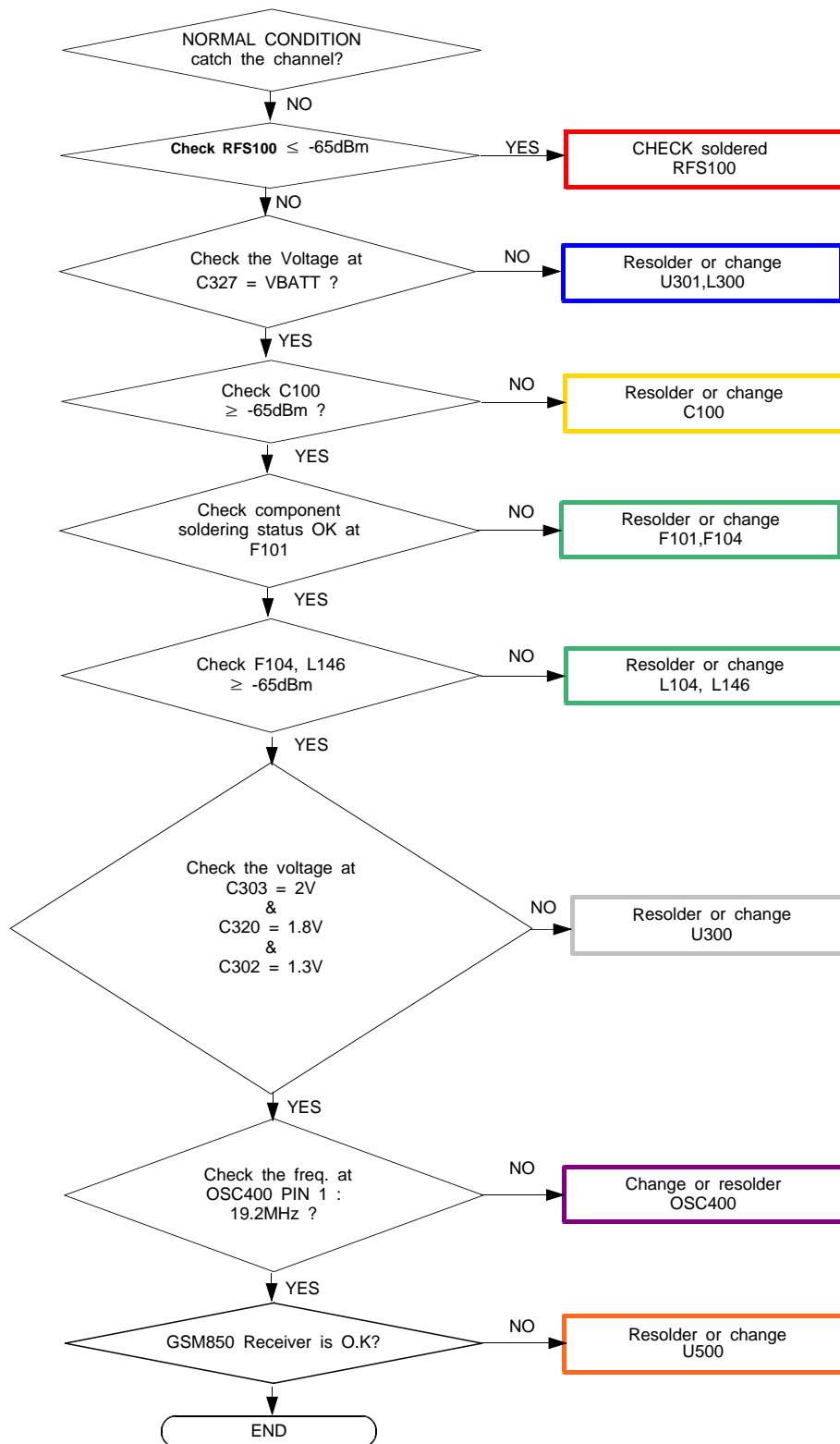

CONTINUOUS RX ON
RF INPUT : 3100CH
AMP : -50dBm

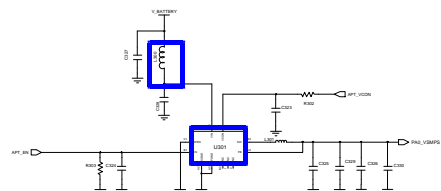
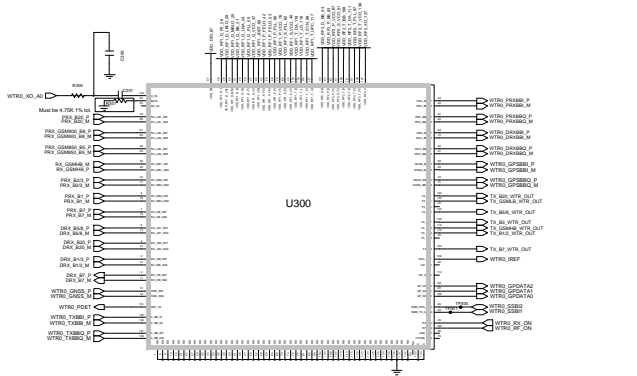
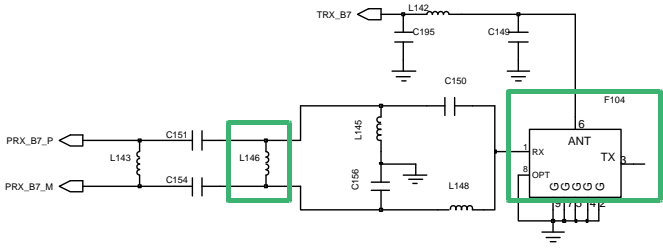
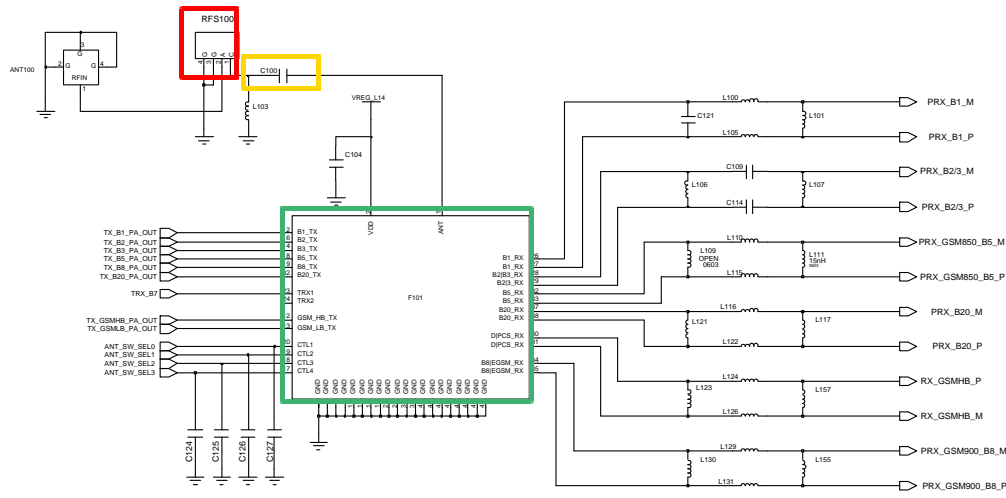

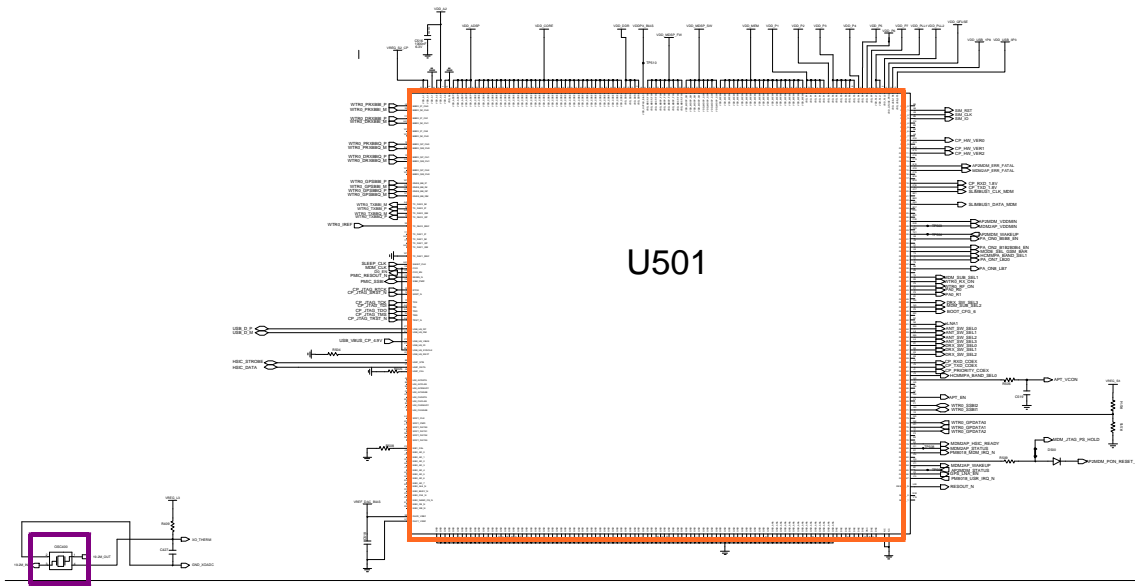

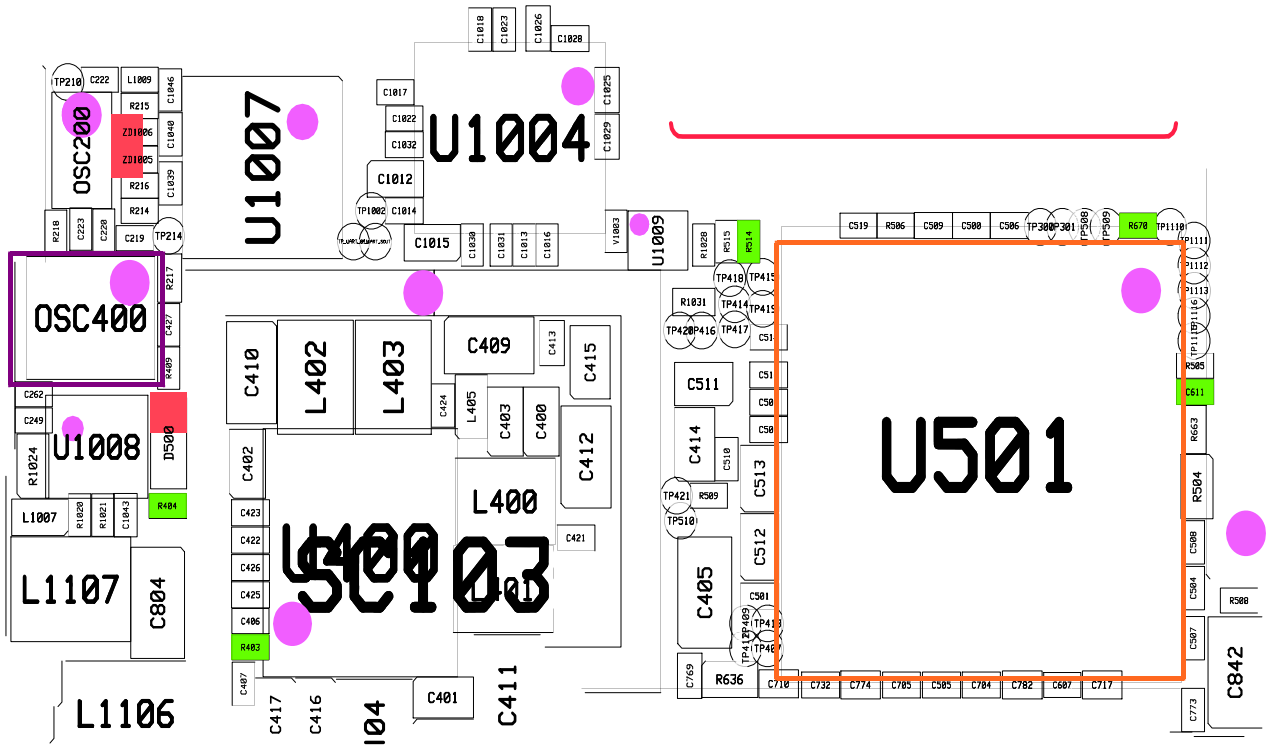
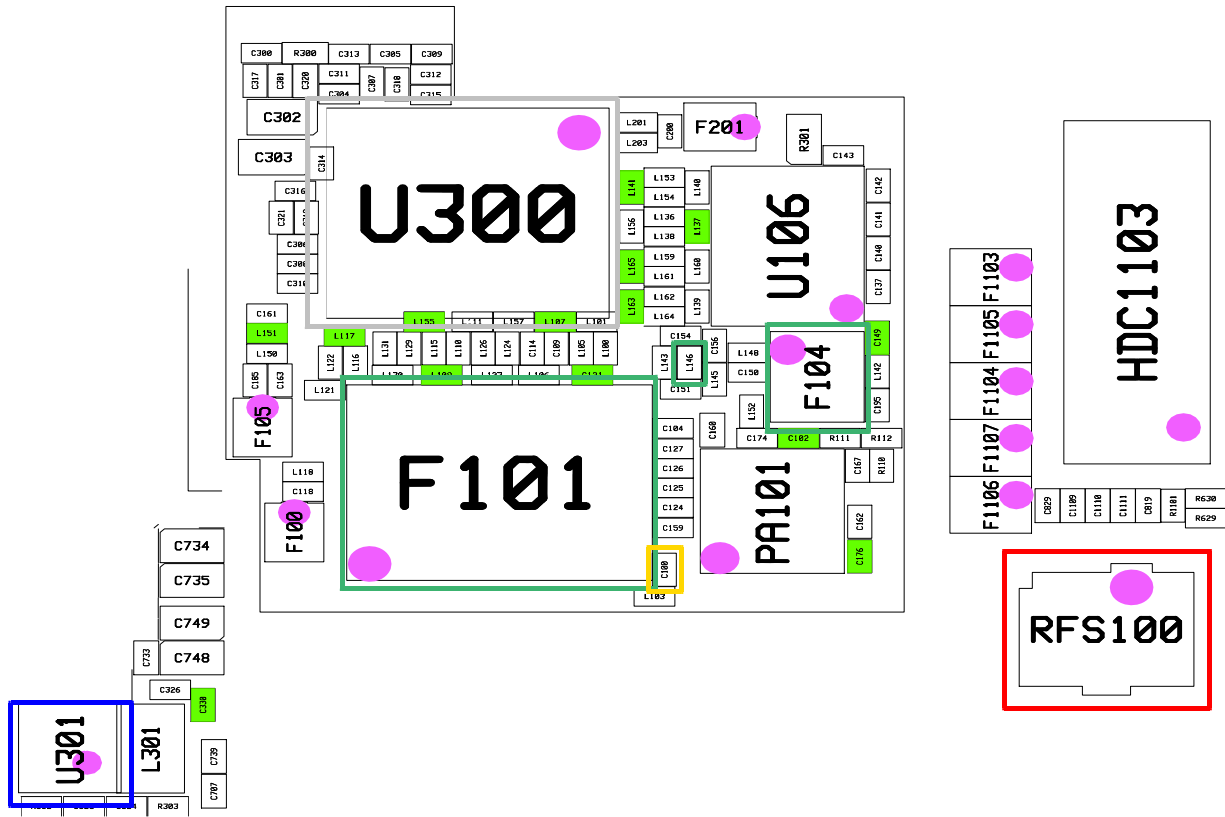

8-3-33. LTE B20 RX

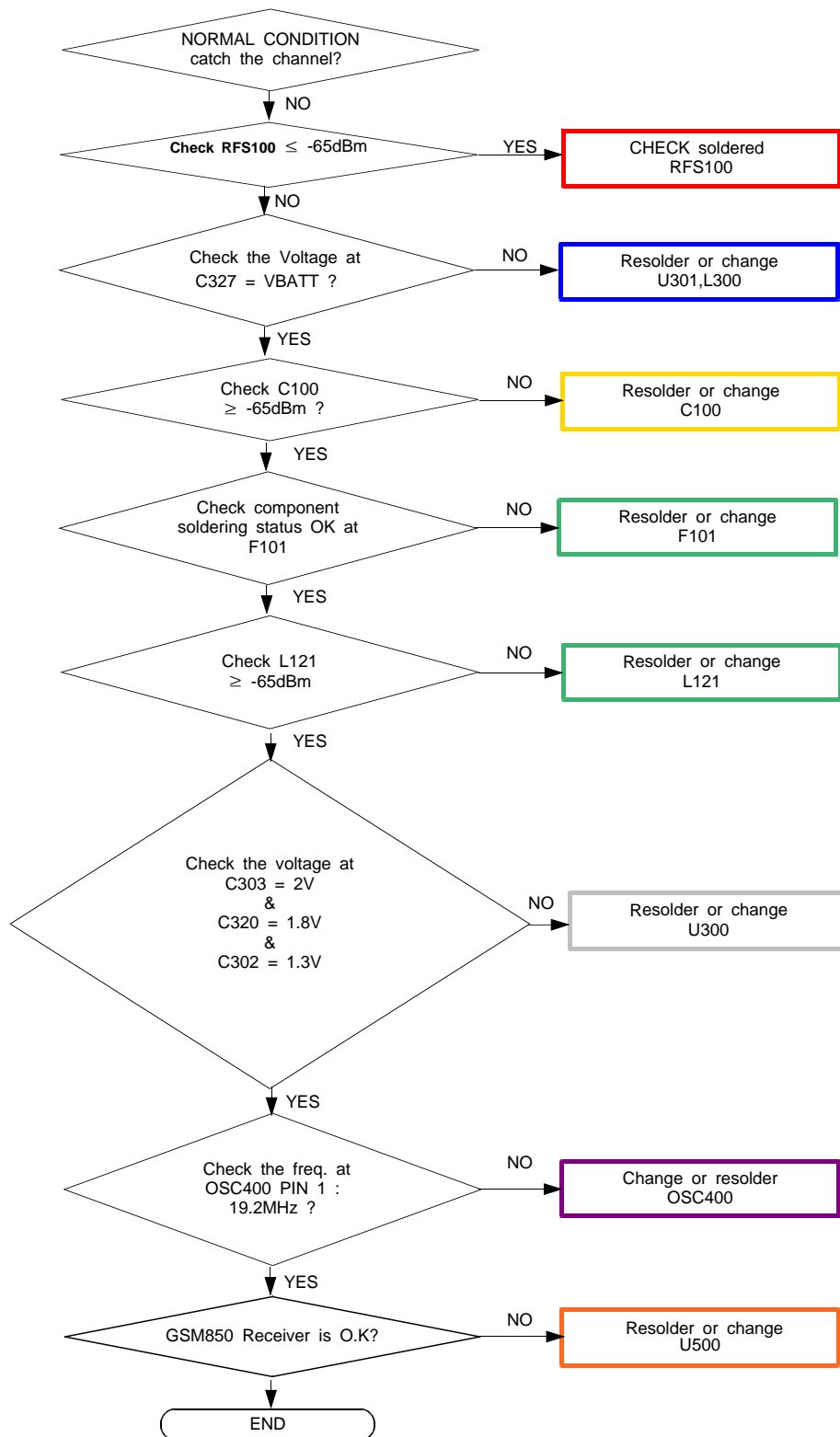

CONTINUOUS RX ON
RF INPUT : 6300CH
AMP : -50dBm

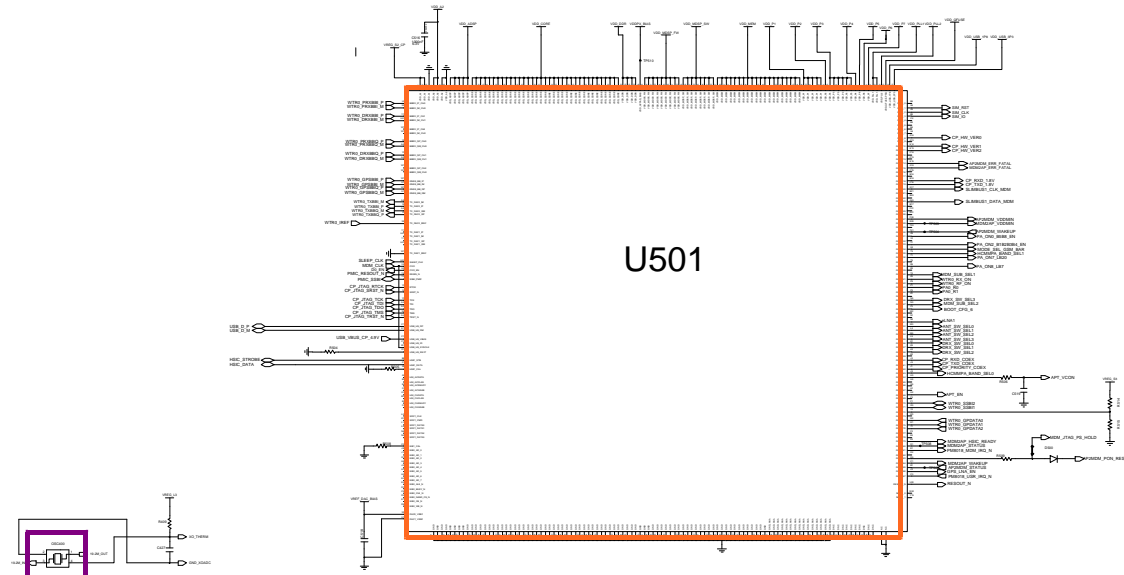
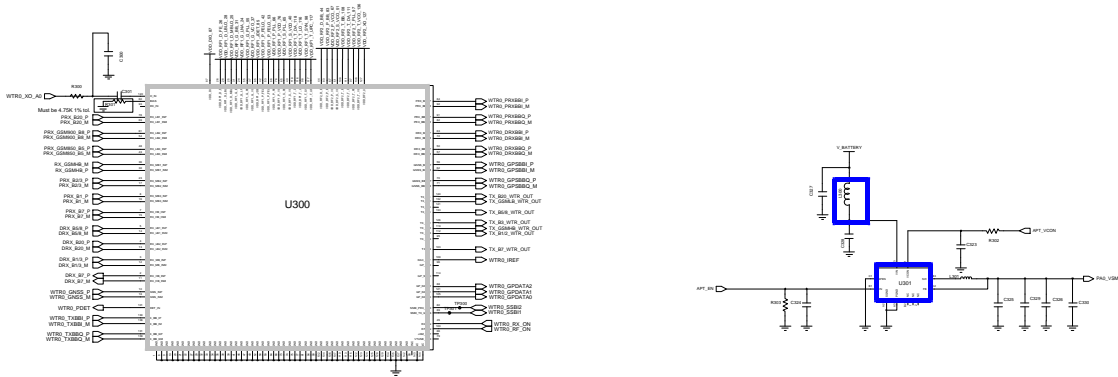
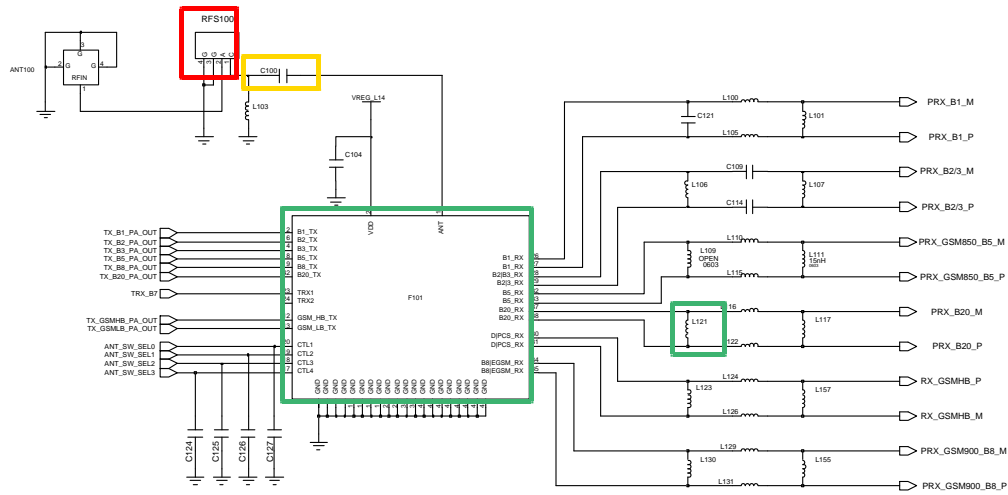

8-3-34. GSM850/GSM900 TX

CONTINUOUS TX ON CONDITION
 TX POWER IDX1 APPLIED
 GSM850 CH : 190
 GSM900 CH : 62
 RBW : 100KHz
 VBW : 100KHz
 SPAN : 10MHz
 REF LEV. : 10dBm
 ATT. : 20dB

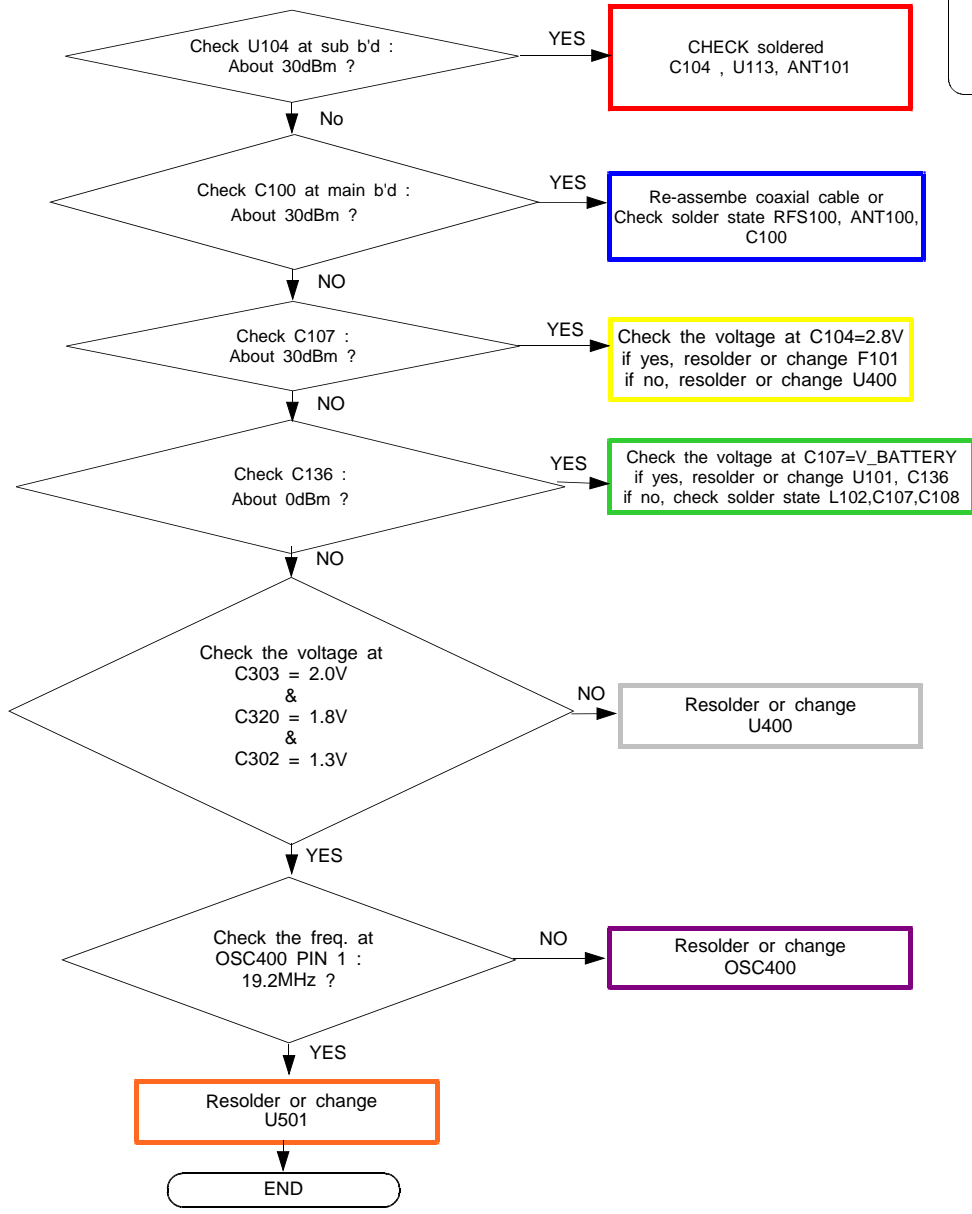

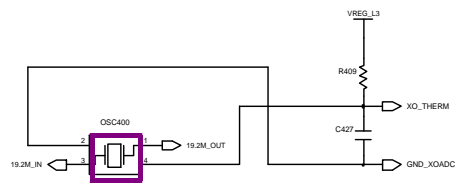
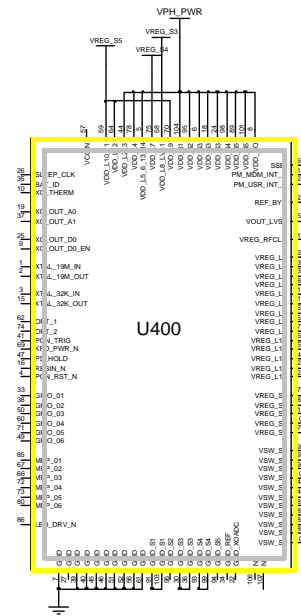
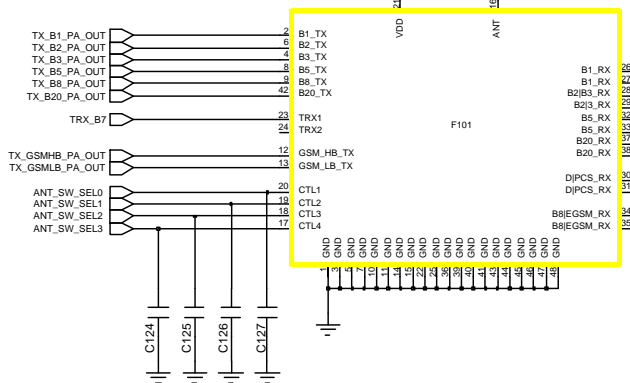
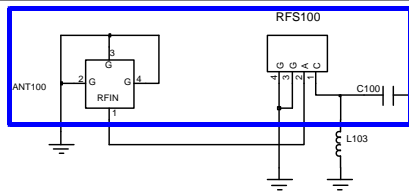
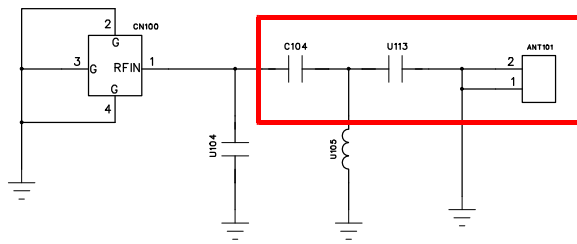

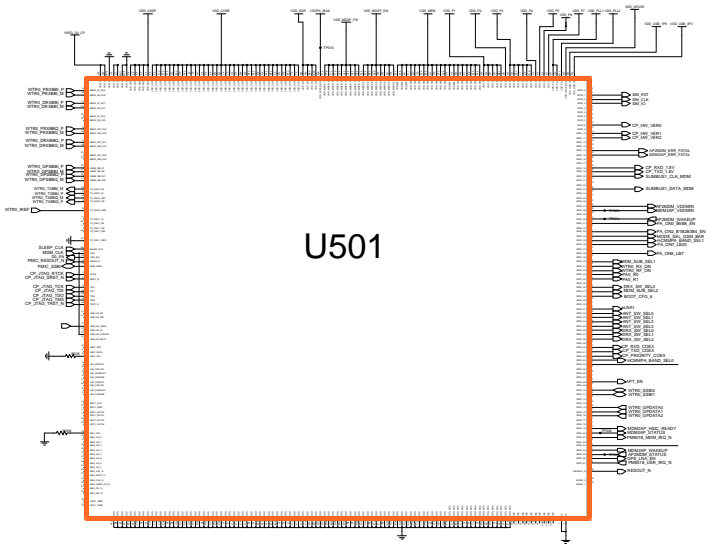
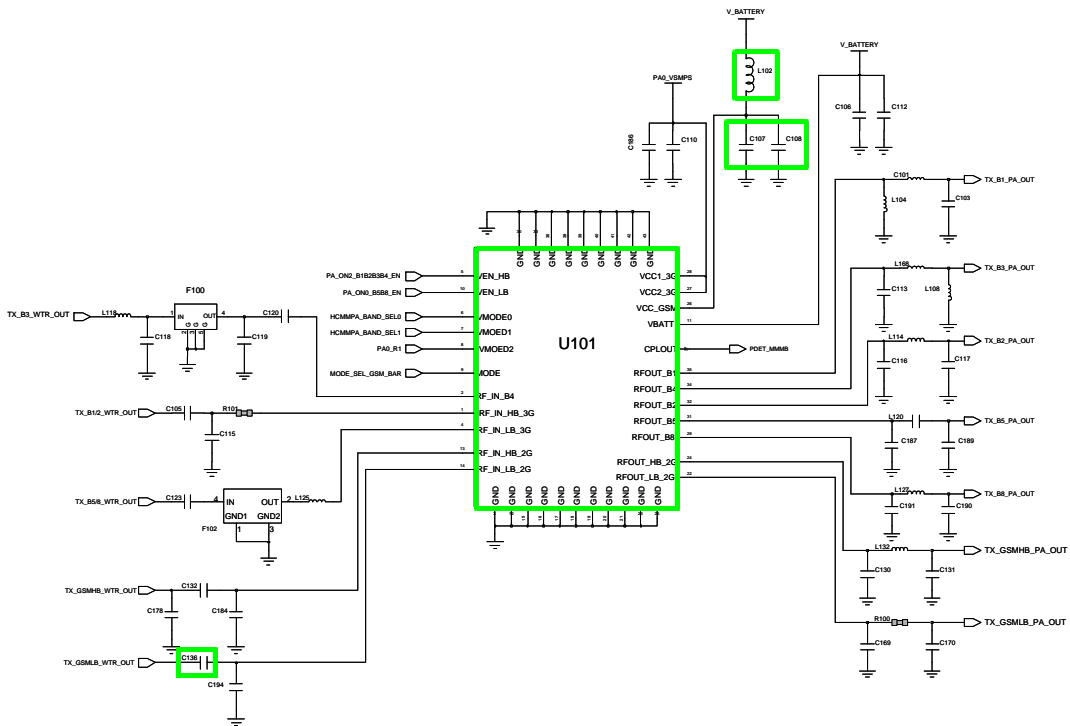

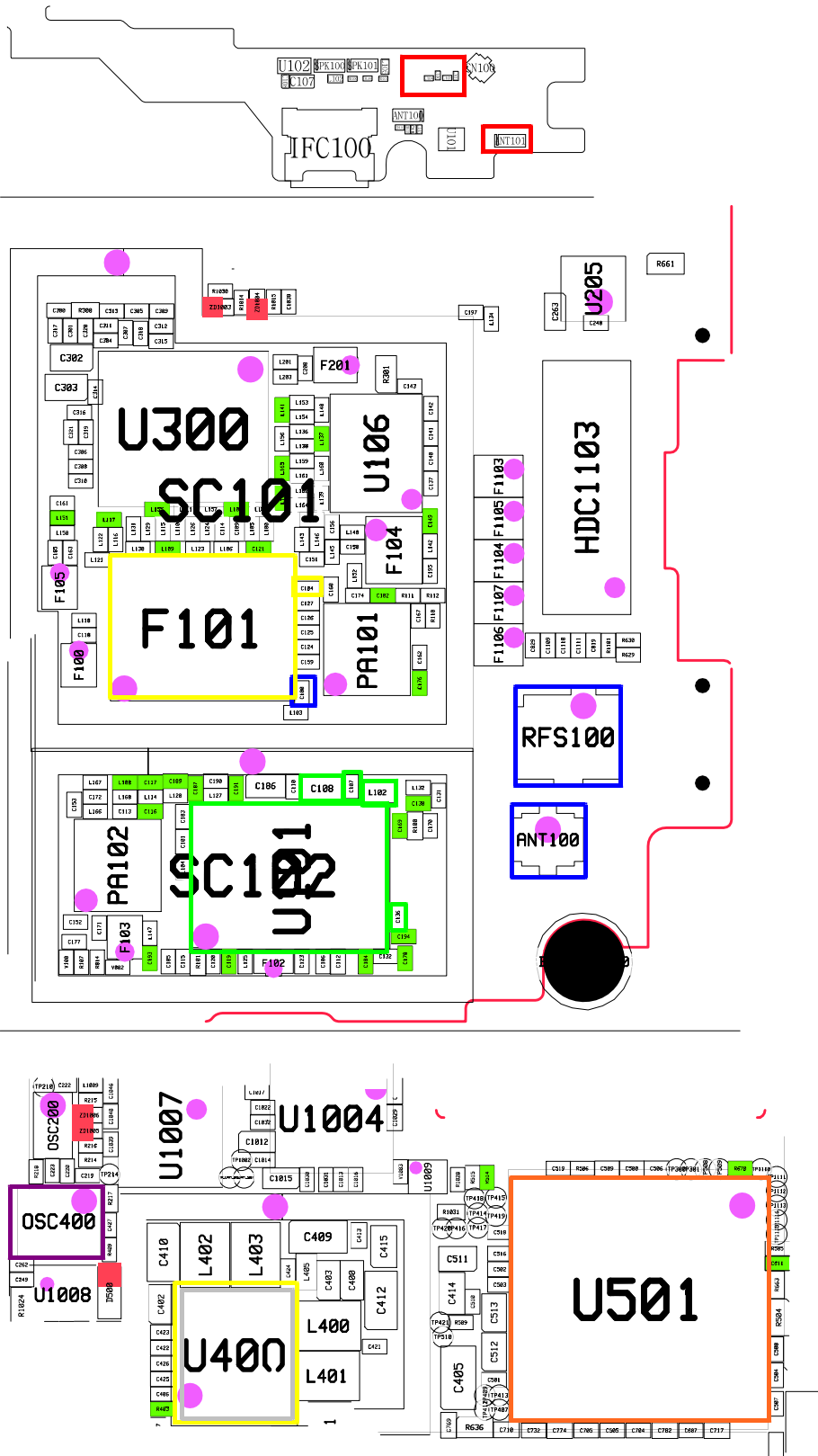

8-3-35. DCS/PCS TX

CONTINUOUS TX ON CONDITION
 TX POWER IDX1 APPLIED
 DCS CH : 698
 PCS CH : 661
 RBW : 100KHz
 VBW : 100KHz
 SPAN : 10MHz
 REF LEV. : 10dBm
 ATT. : 20dB

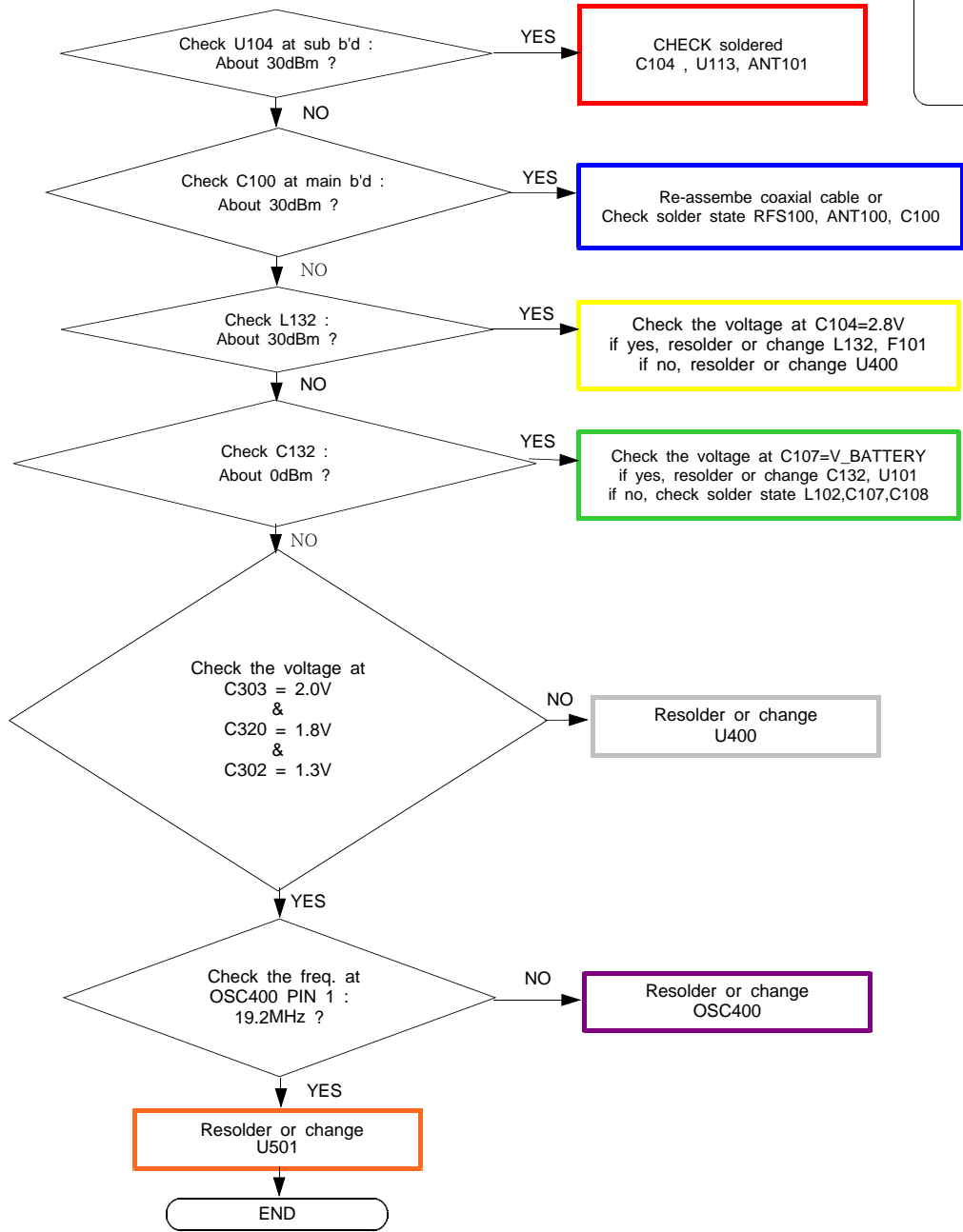

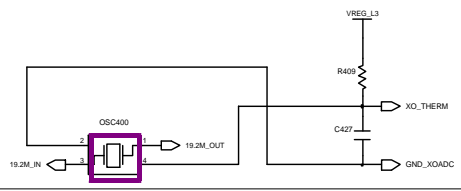
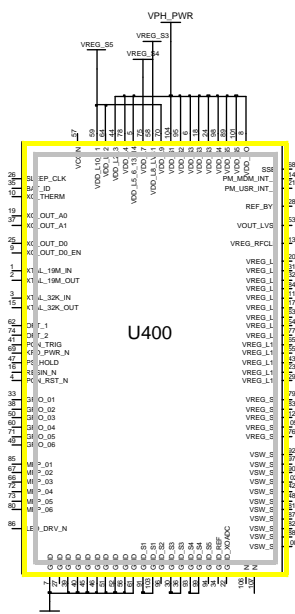
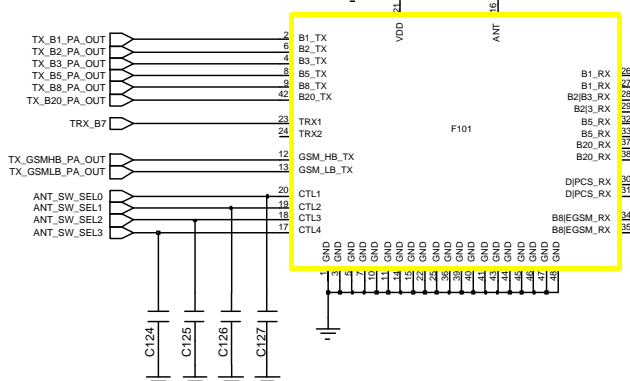
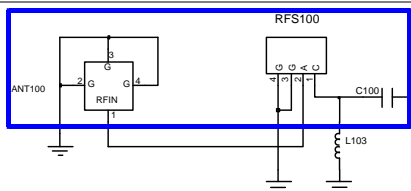
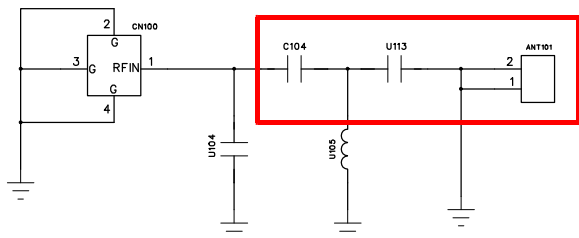

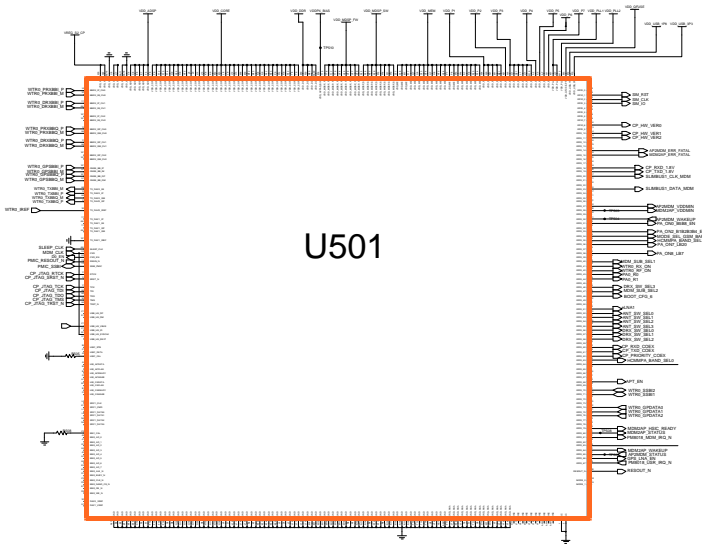
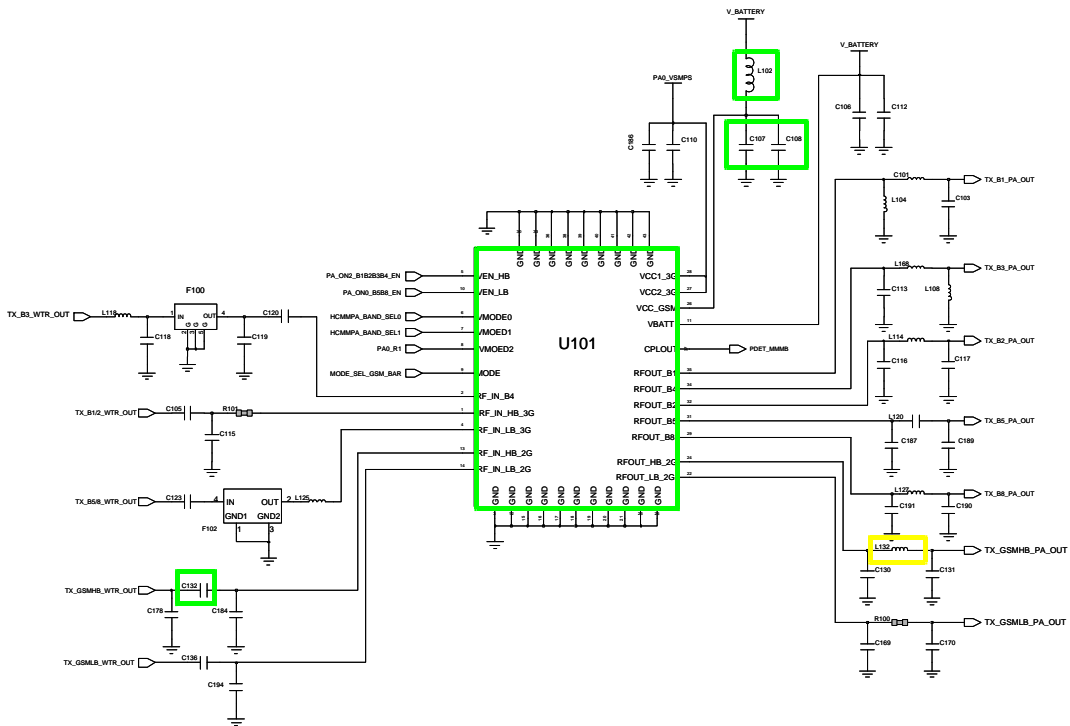

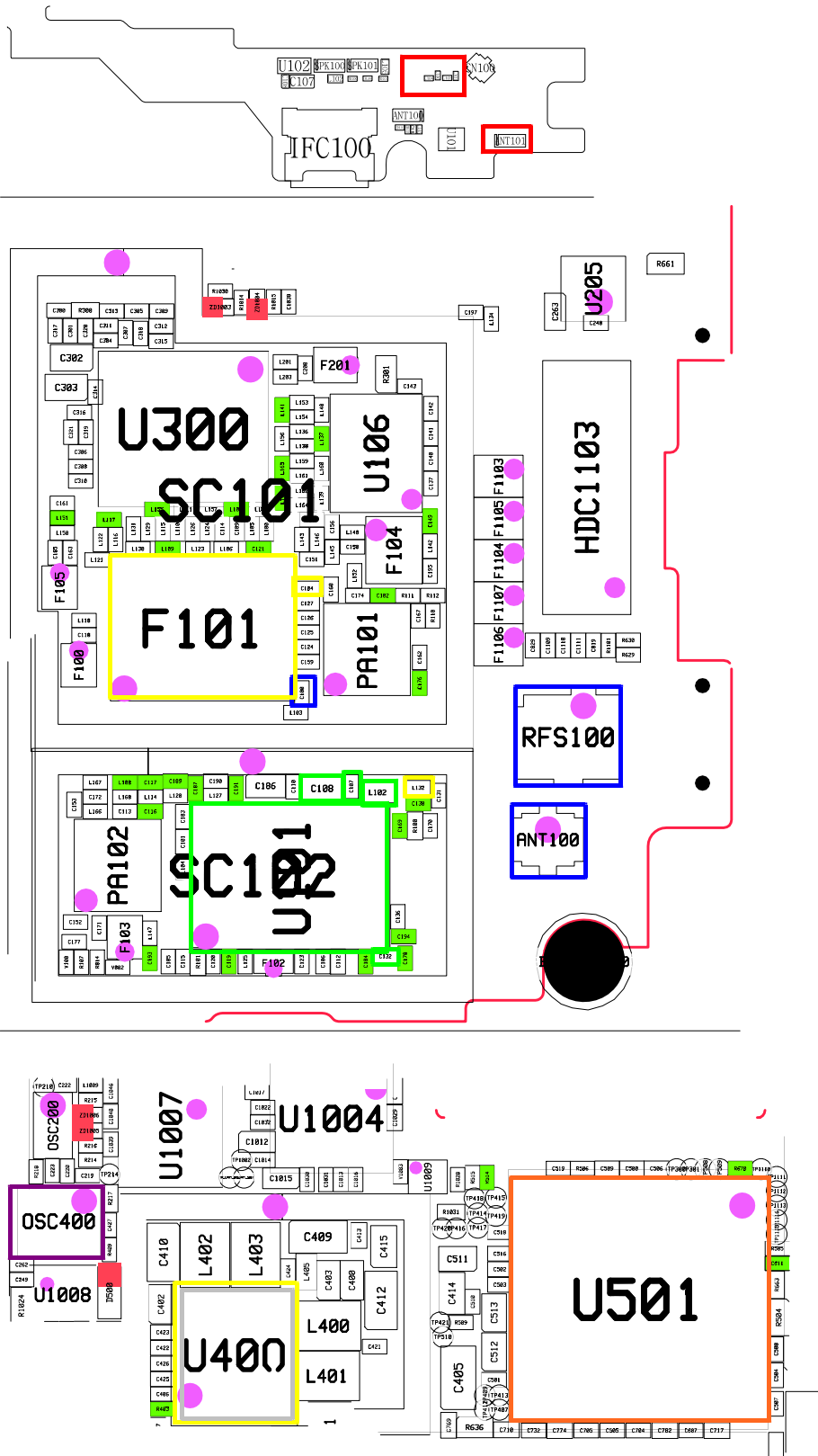

8-3-36. WCDMA2100 / LTE B1 TX

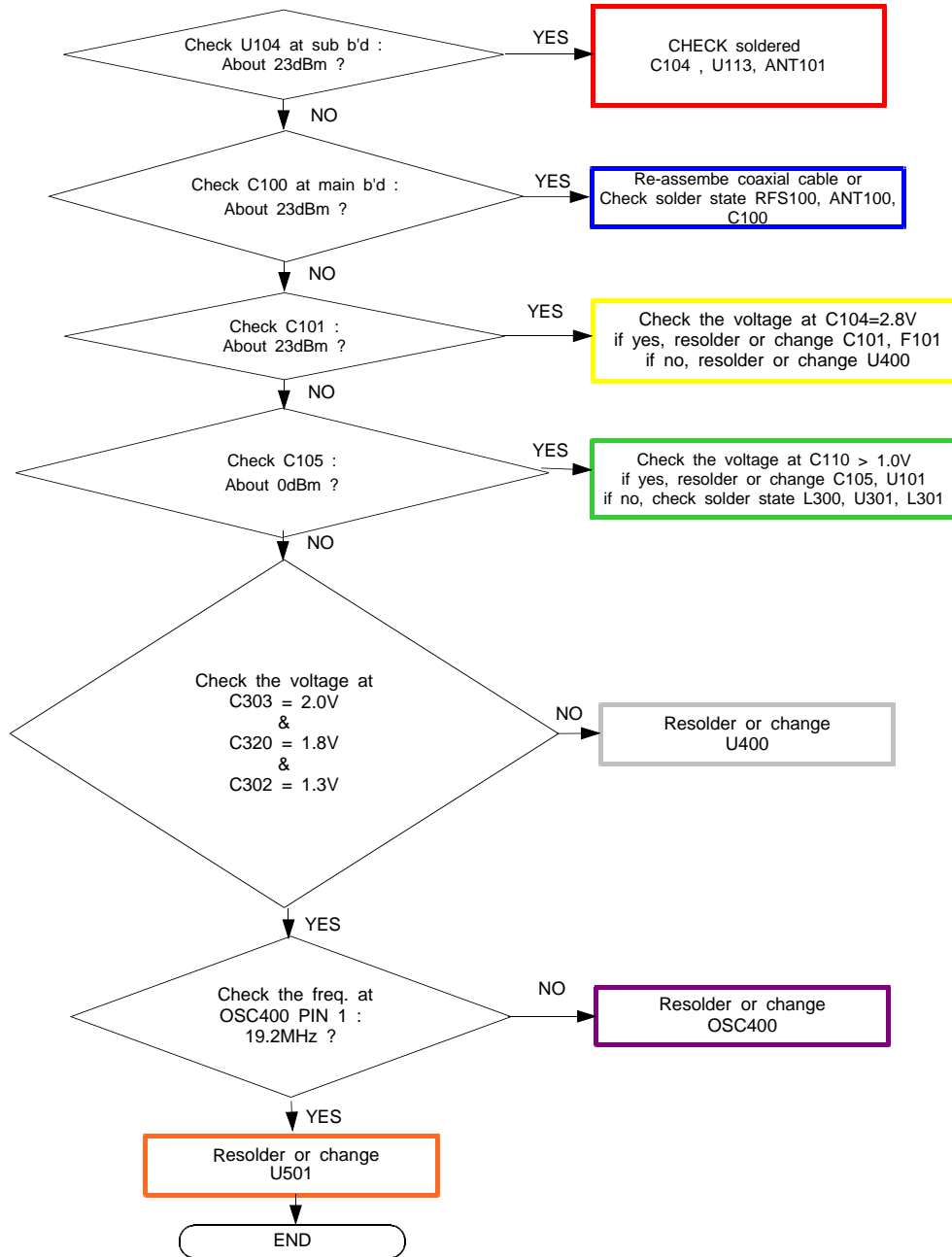

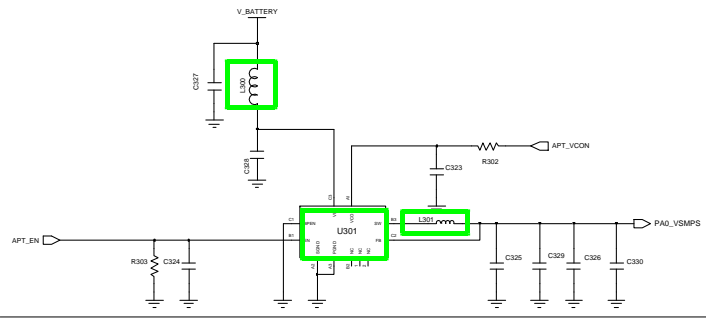
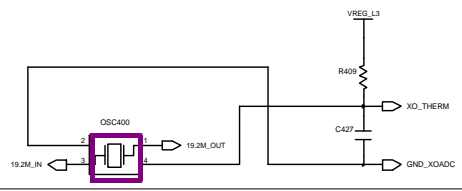
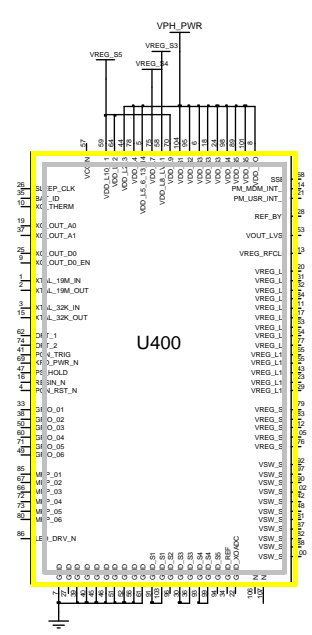
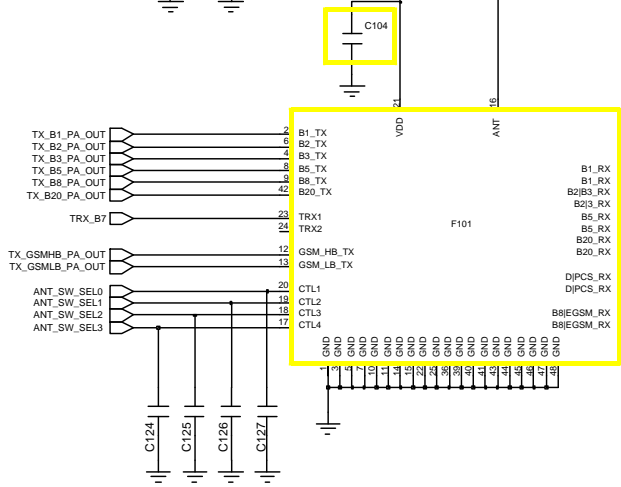
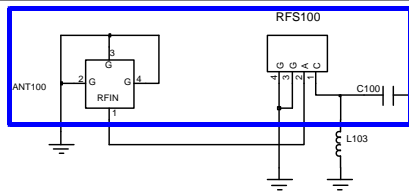
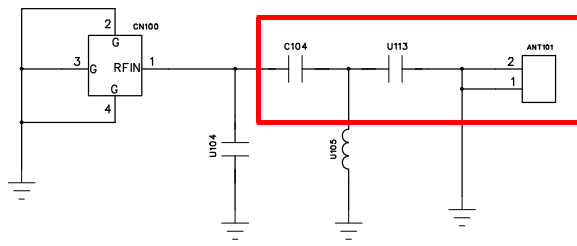

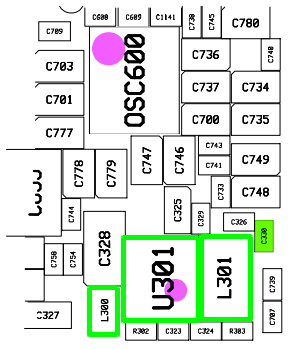
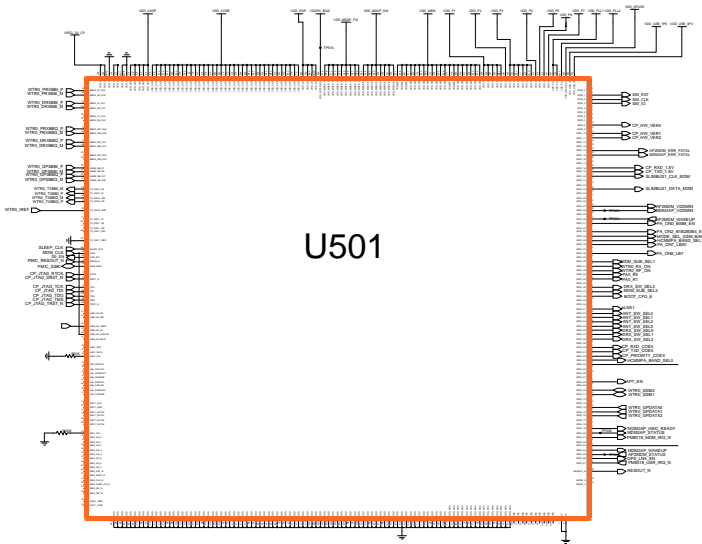
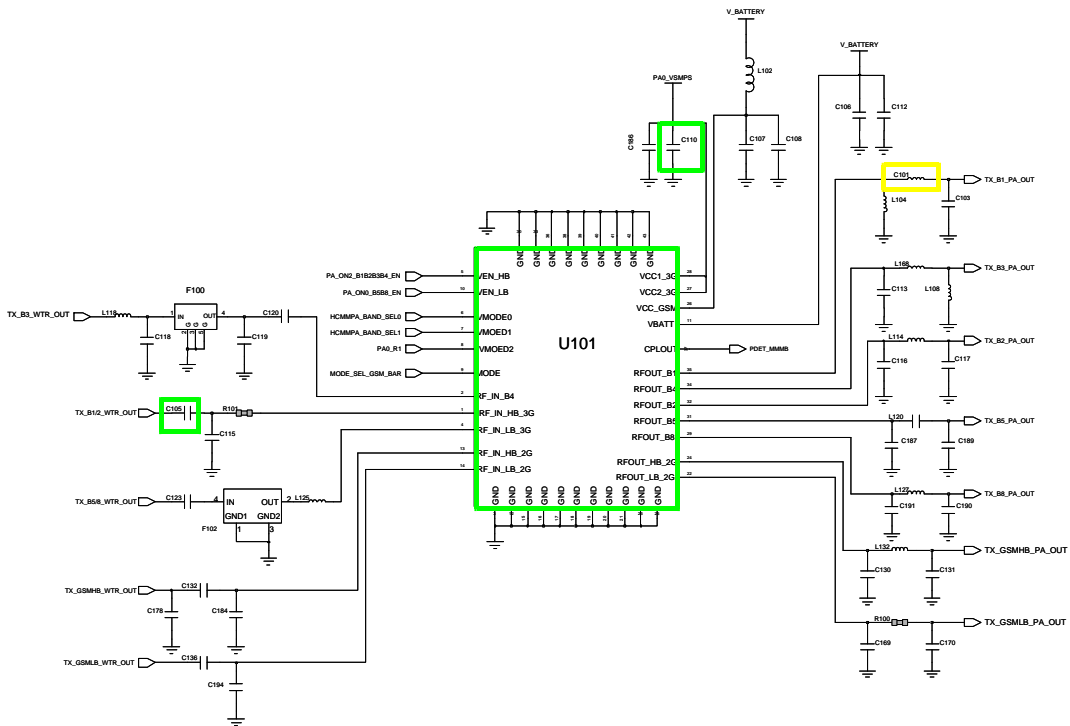

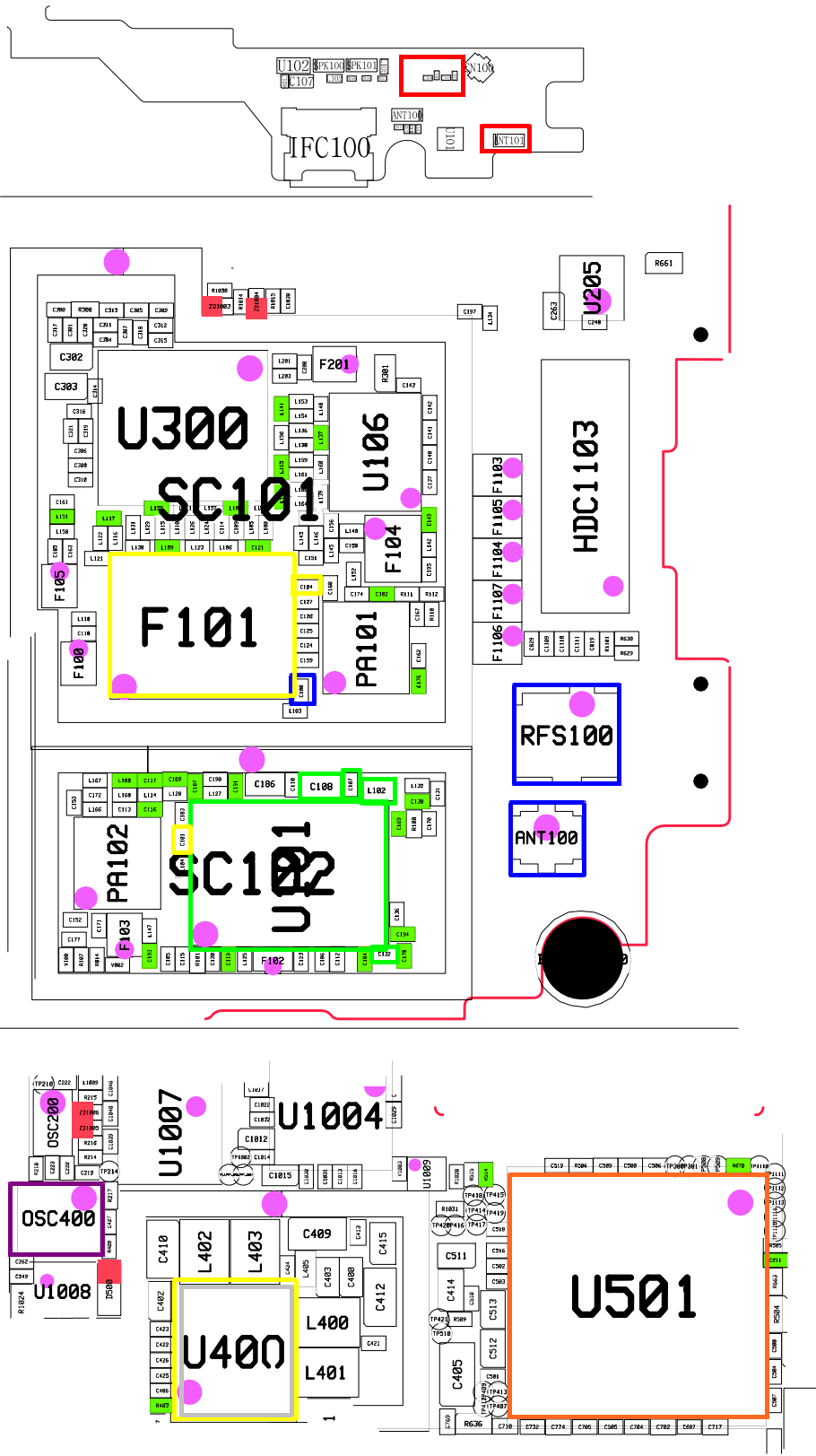

8-3-37. WCDMA850 / LTE B5 TX

CONTINUOUS TX ON CONDITION
 TX POWER IDX1 APPLIED
 WCDMA850 CH : 4182
 RBW : 100KHz
 VBW : 100KHz
 SPAN : 10MHz
 REF. LEV. : 10dBm
 ATT. : 20dB

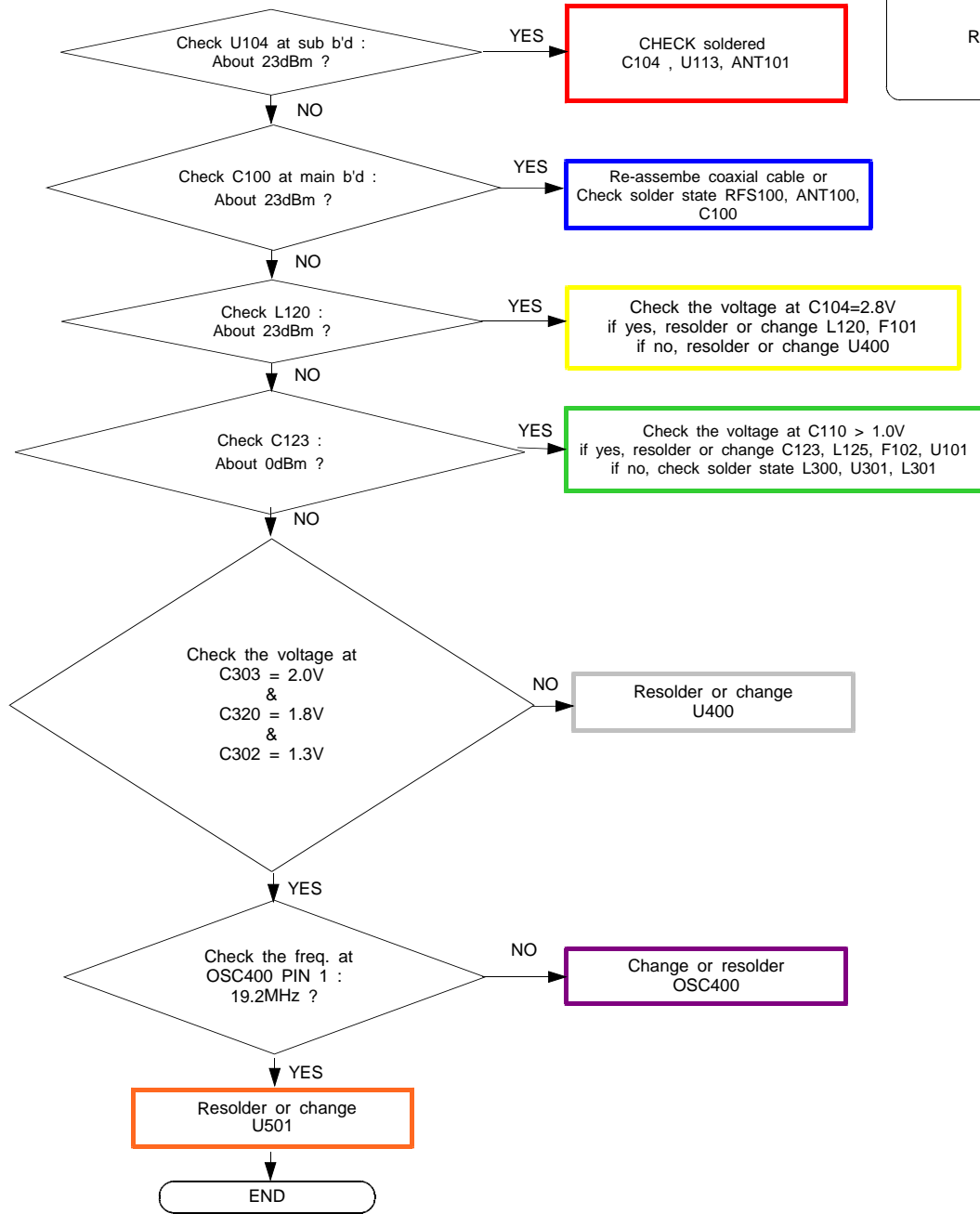

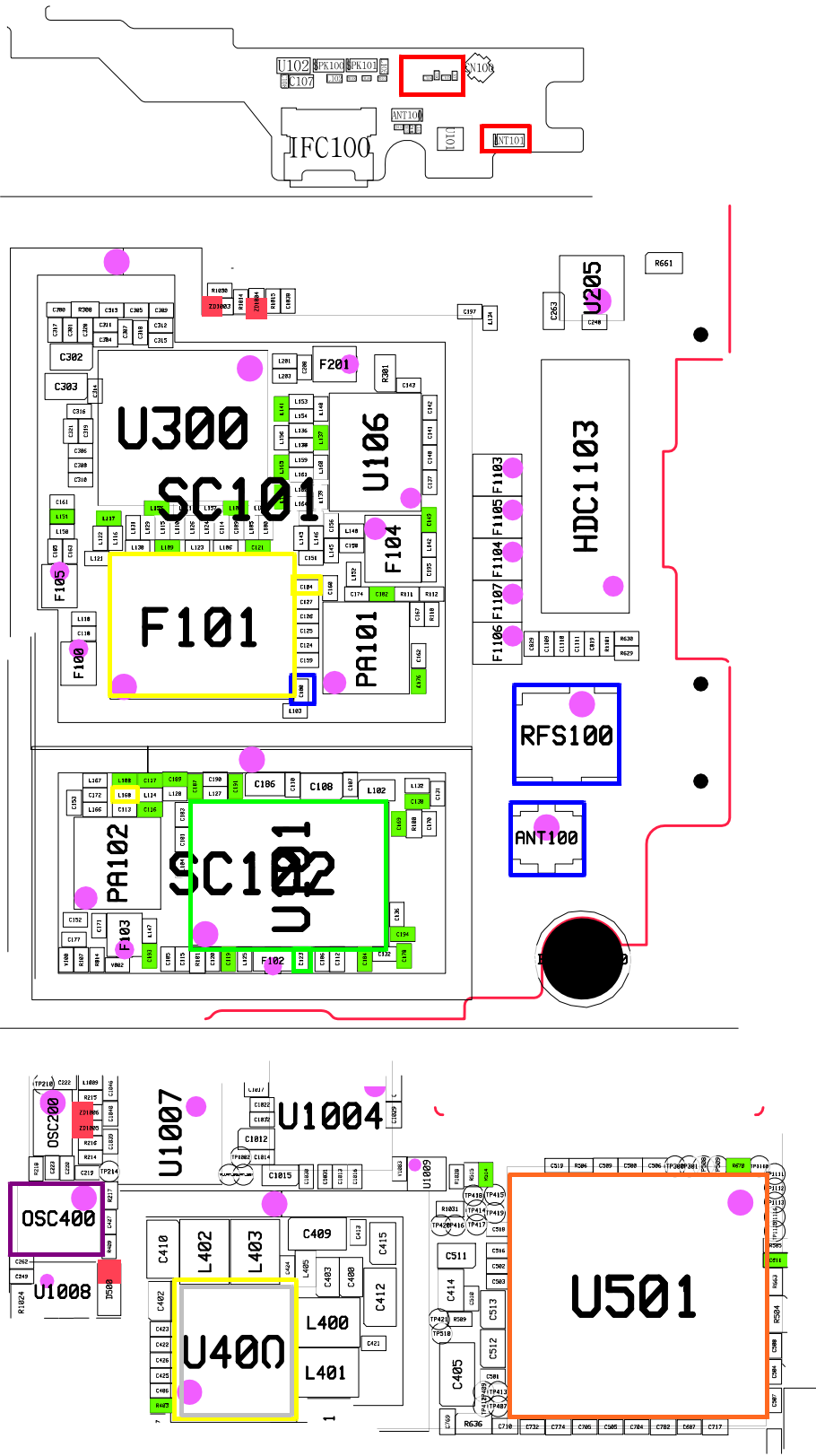

8-3-38. WCDMA900 / LTE B8 TX

CONTINUOUS TX ON CONDITION
 TX POWER IDX1 APPLIED
 WCDMA900 CH : 2788
 RBW : 100KHz
 VBW : 100KHz
 SPAN : 10MHz
 REF LEV. : 10dBm
 ATT. : 20dB

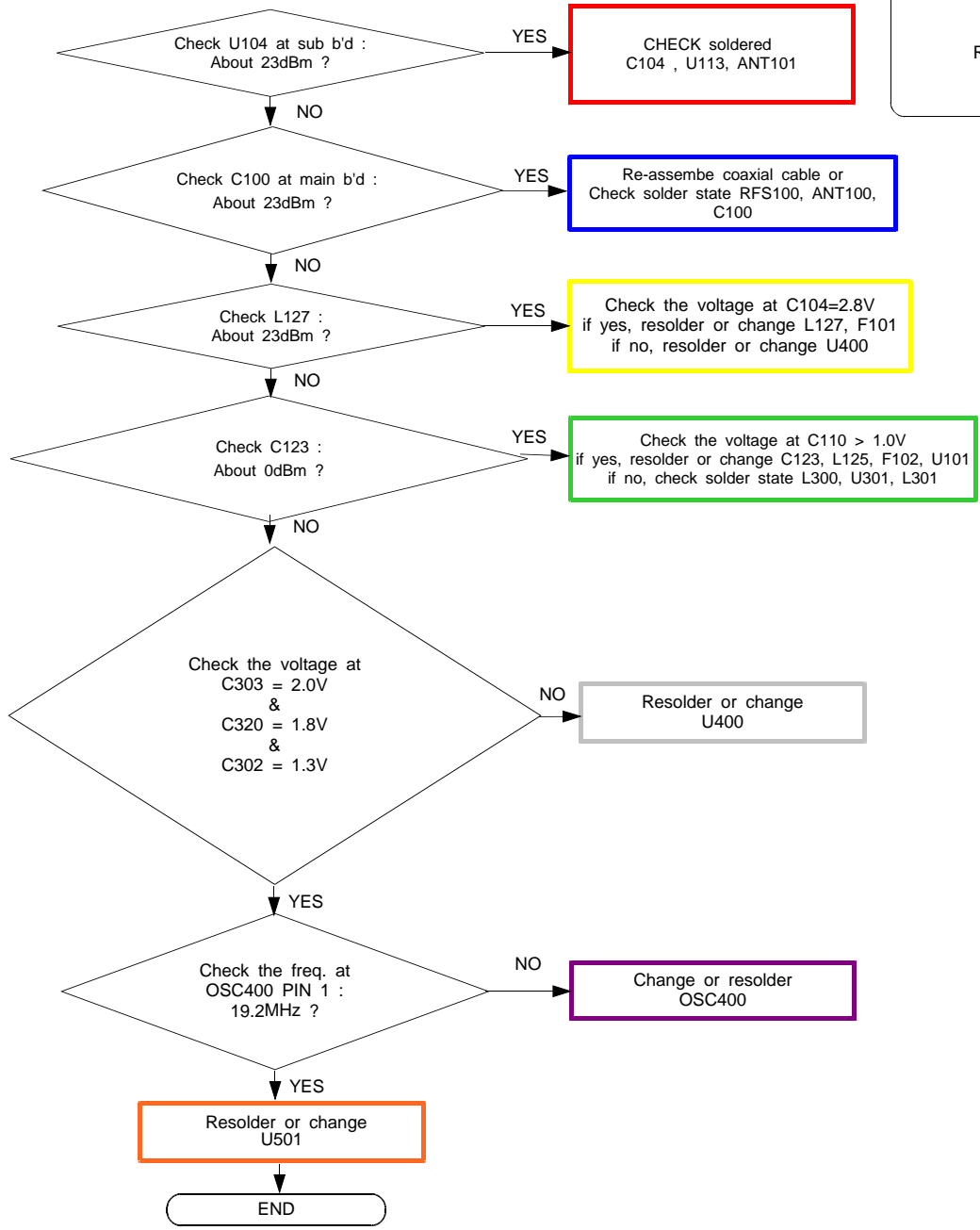

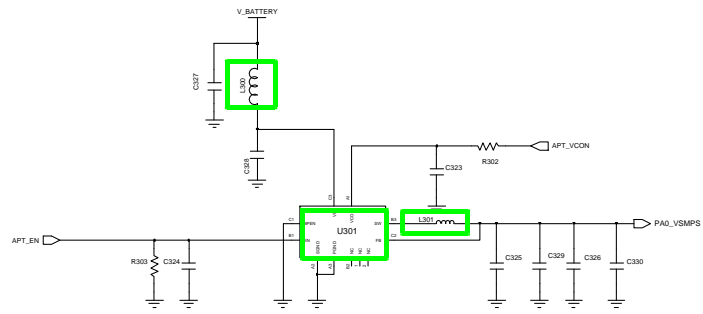
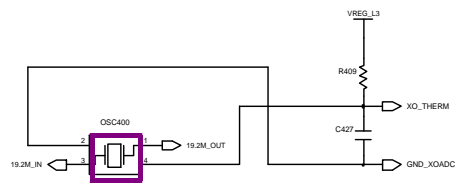
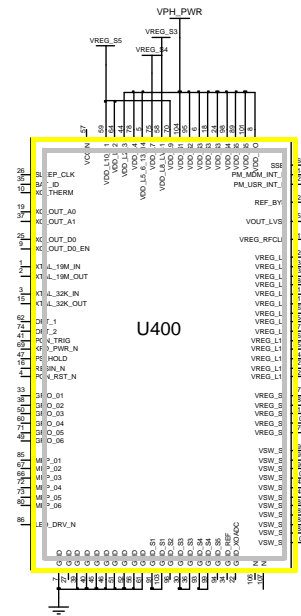
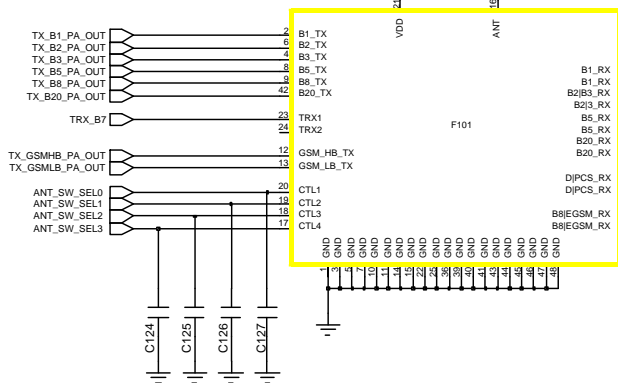
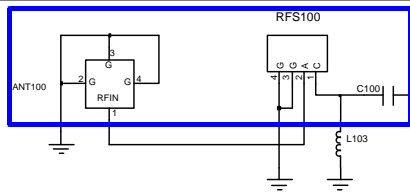
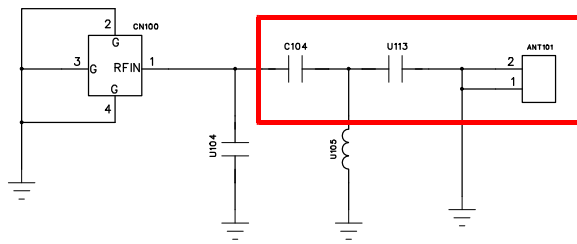

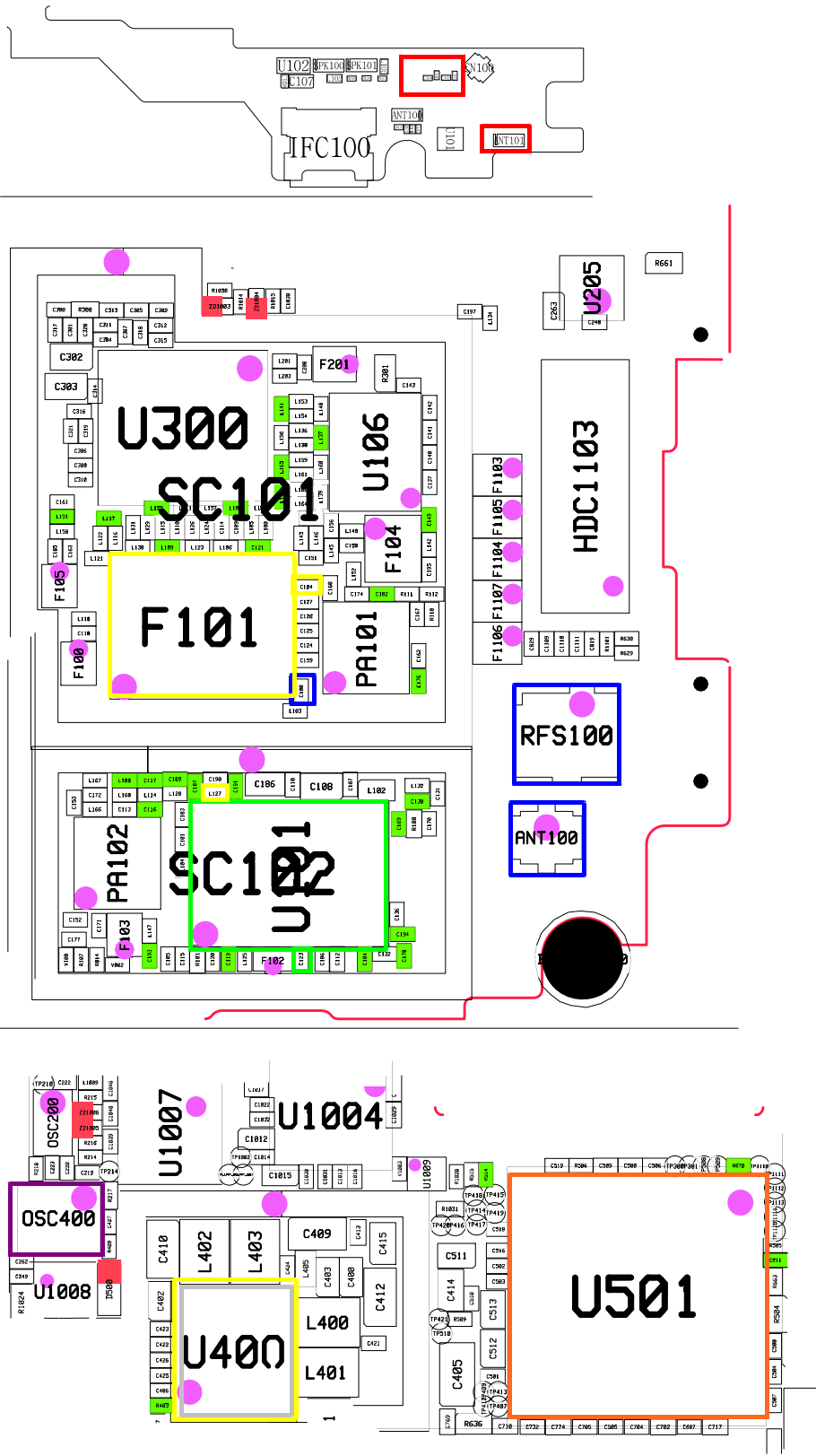

8-3-39. WCDMA1900 TX

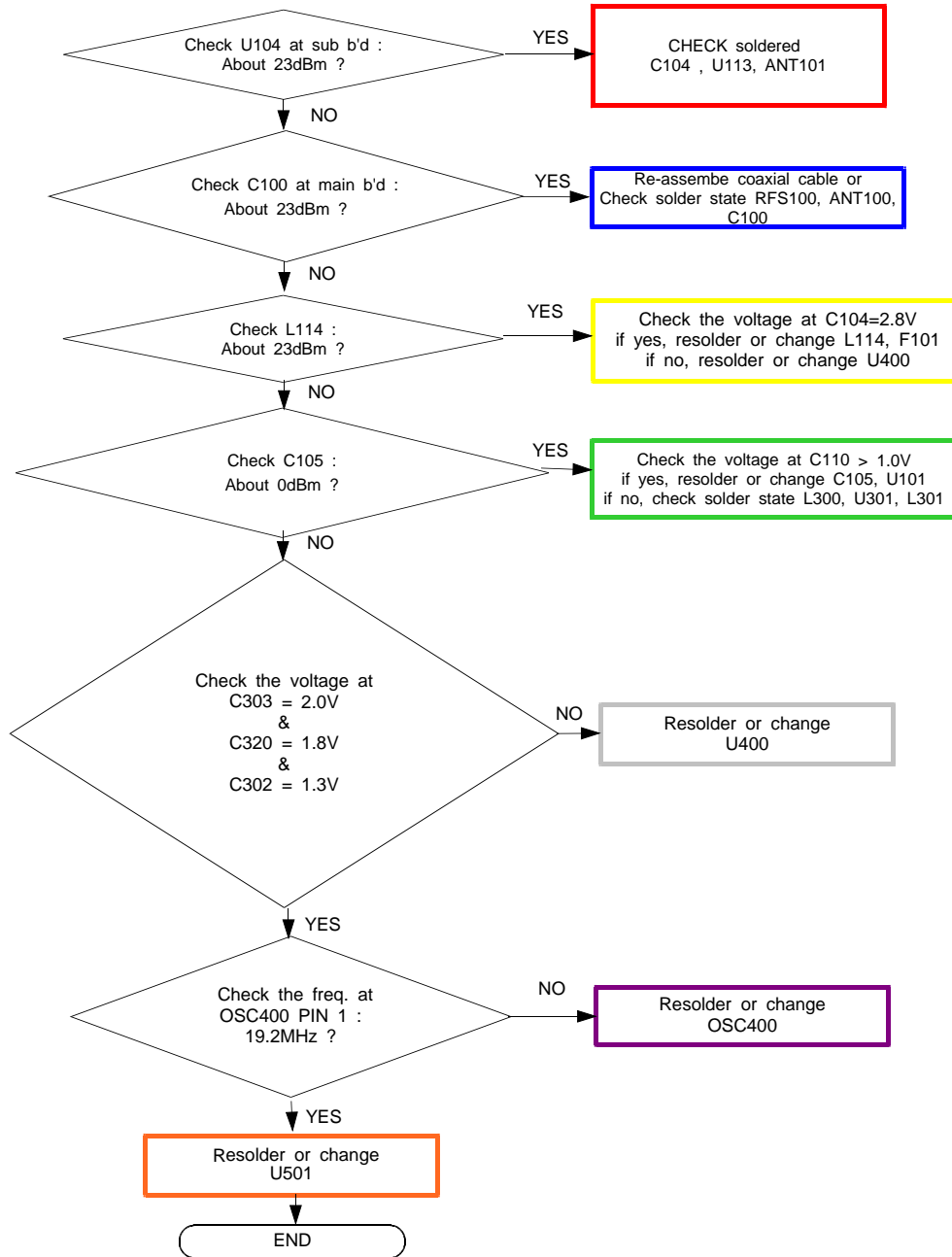

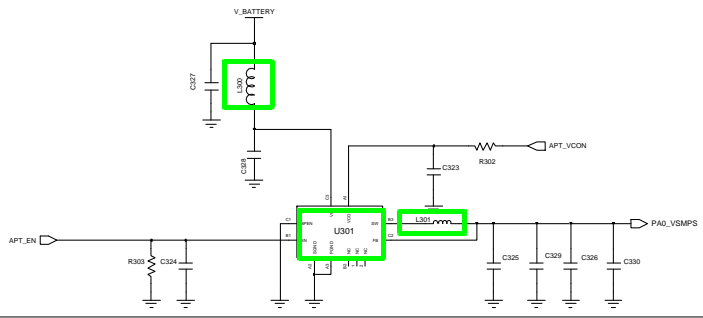
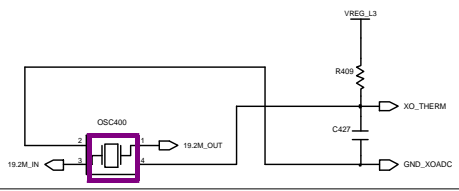
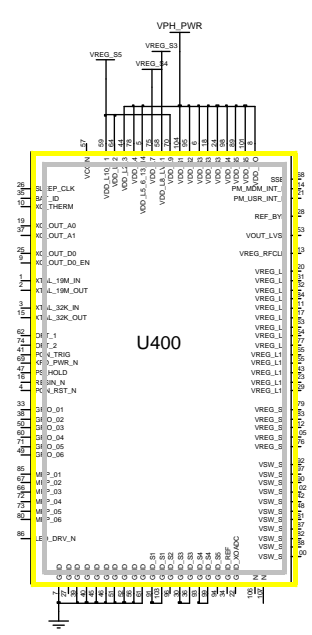
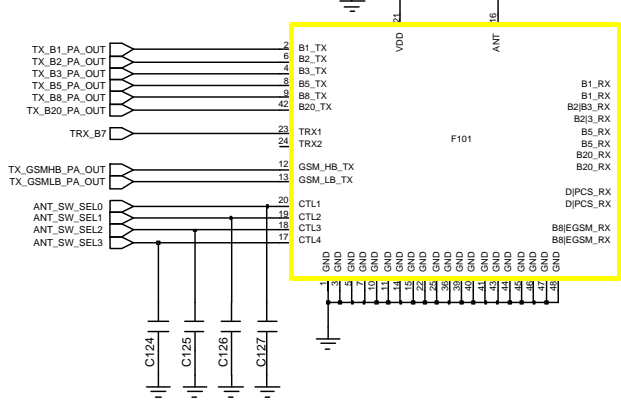
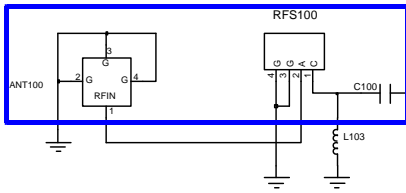
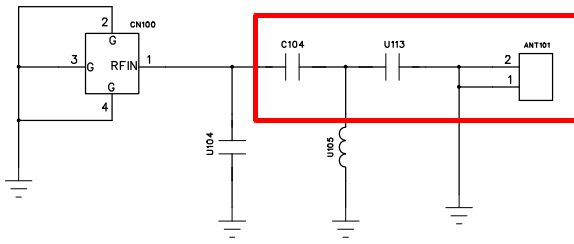

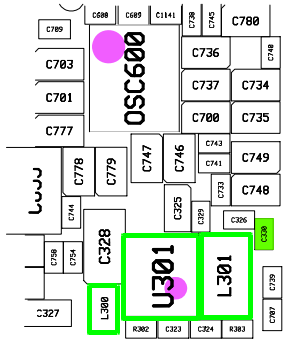
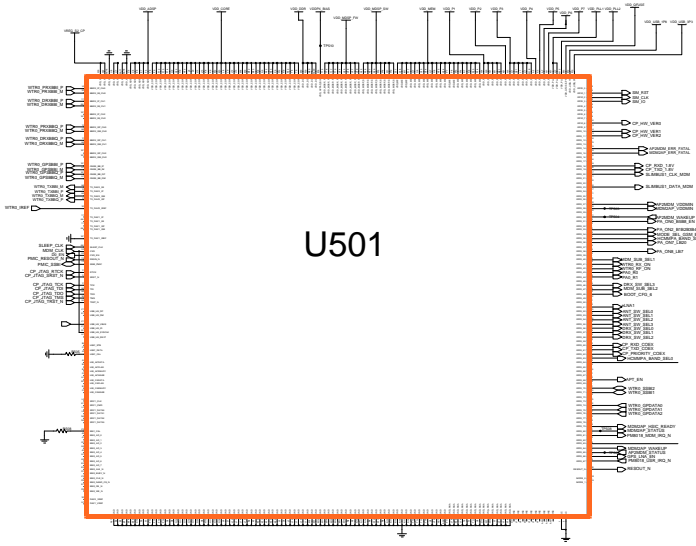
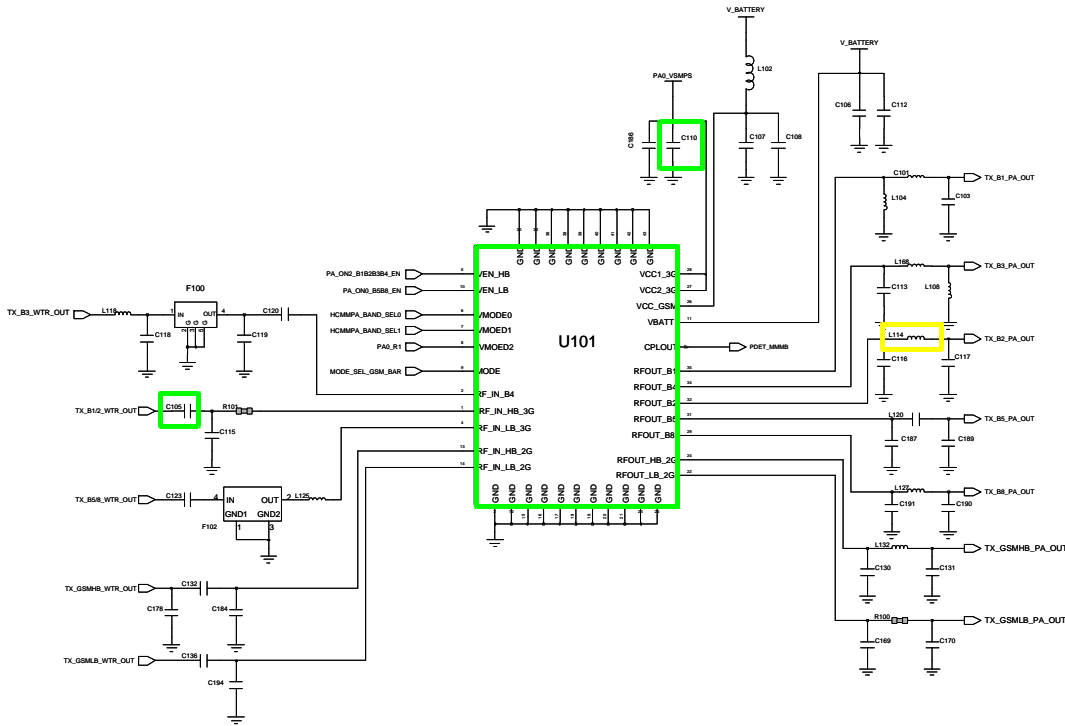

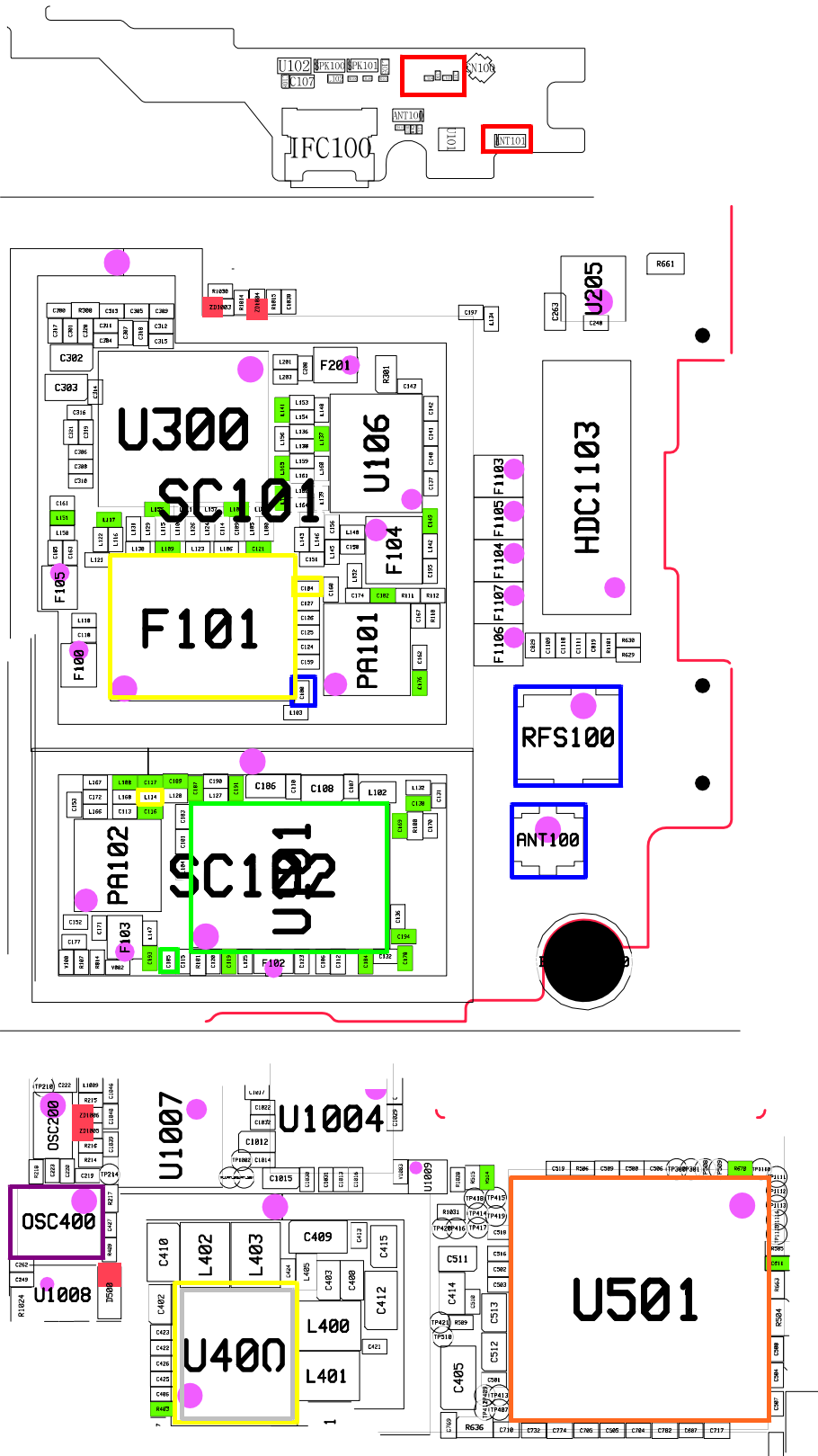

8-3-40. LTE B3 TX

CONTINUOUS TX ON CONDITION APPLIED
 LTE Band8 CH : 21600
 RBW : 100KHz
 VBW : 100KHz
 SPAN : 10MHz
 REF LEV. : 10dBm
 ATT. : 20dB

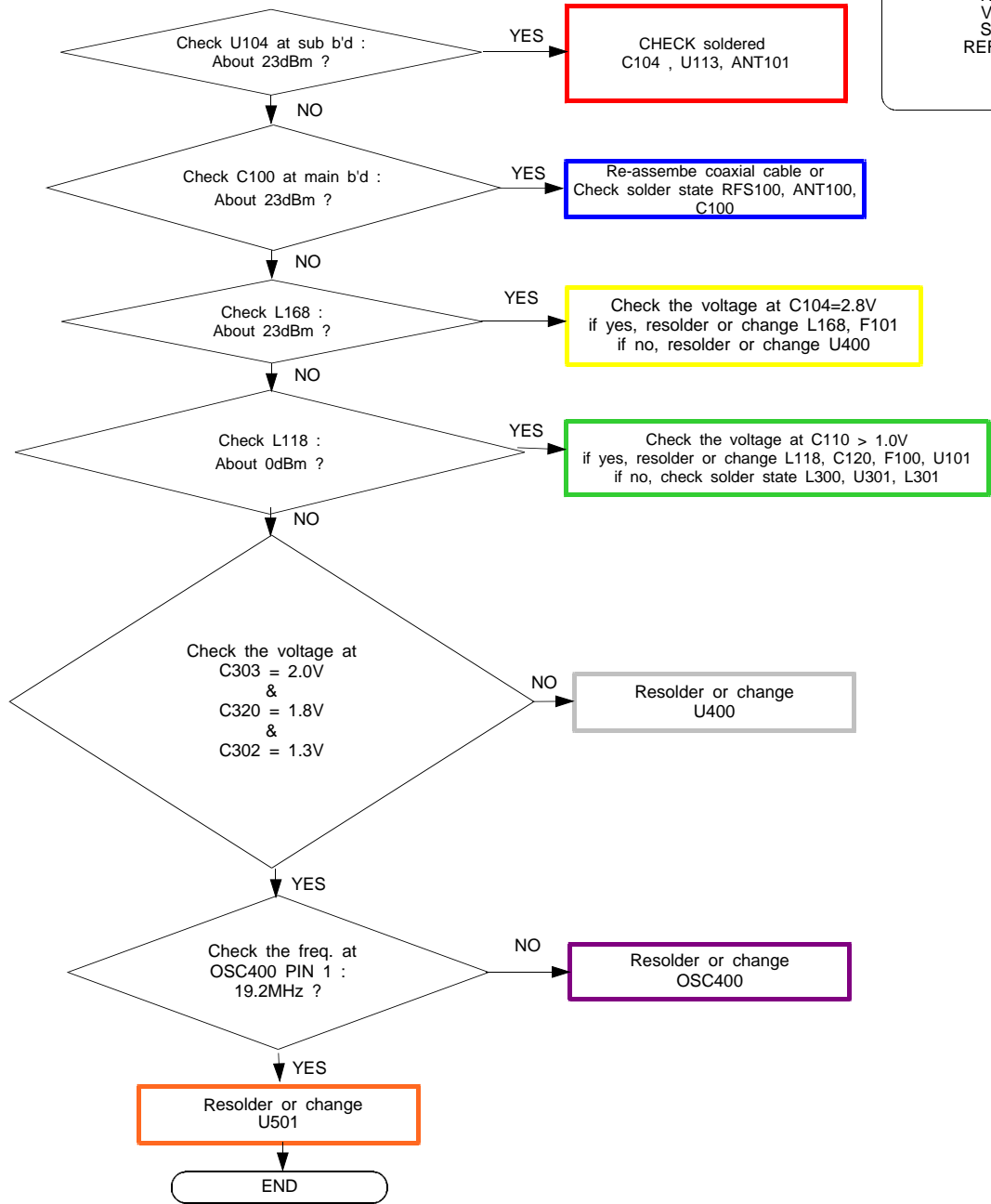

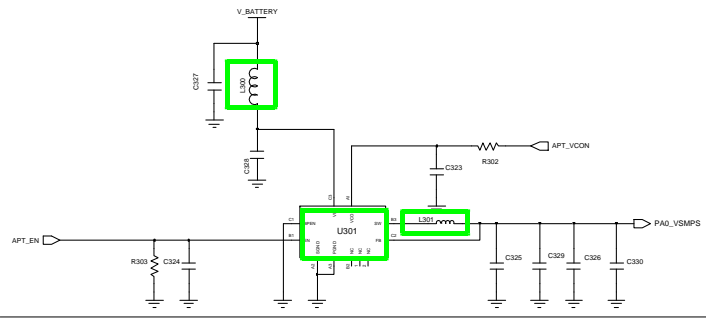
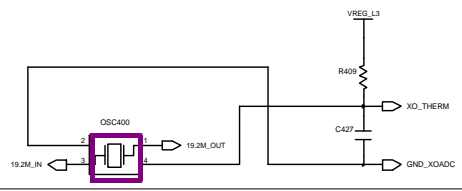
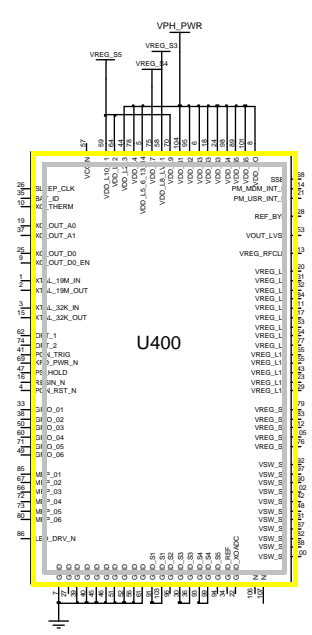
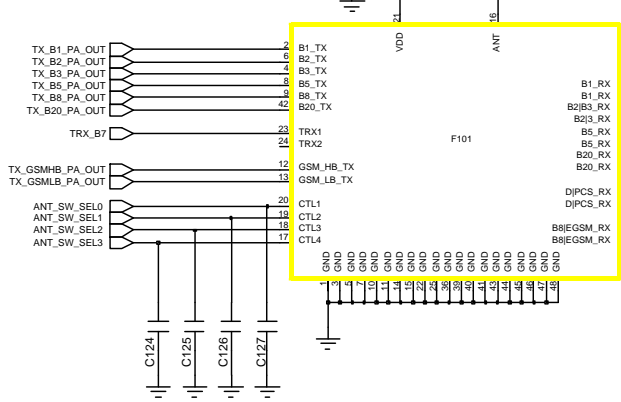
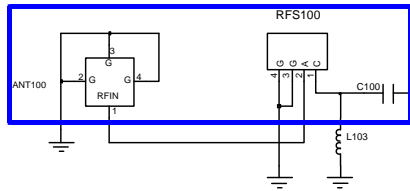
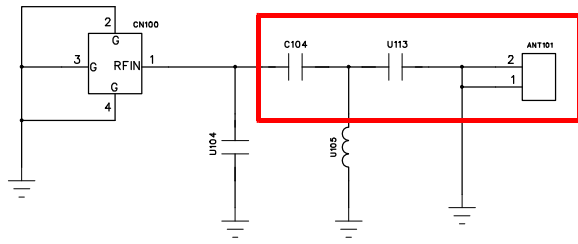

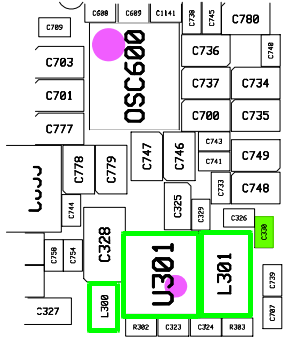
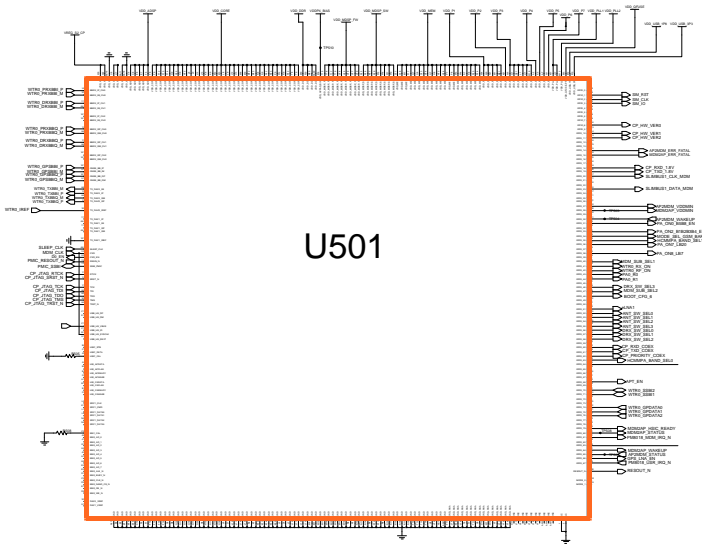
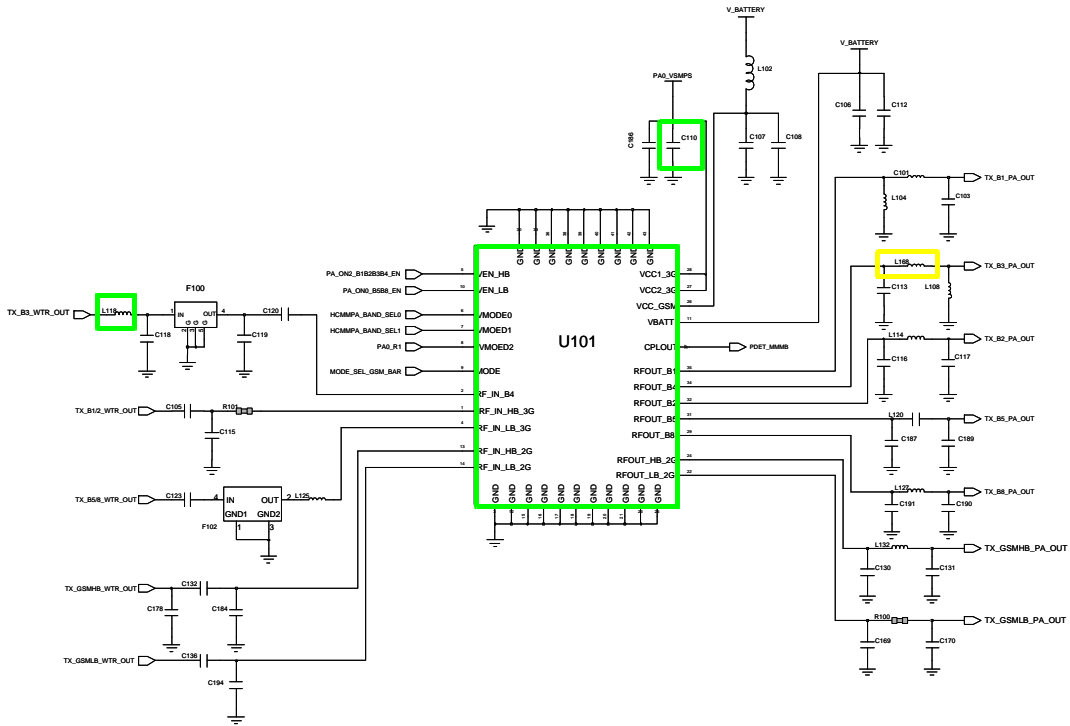

8-3-41. LTE Band7 TX

CONTINUOUS TX ON CONDITION APPLIED
 LTE Band7 CH : 20600
 RBW : 100KHz
 VBW : 100KHz
 SPAN : 10MHz
 REF LEV. : 10dBm
 ATT. : 20dB

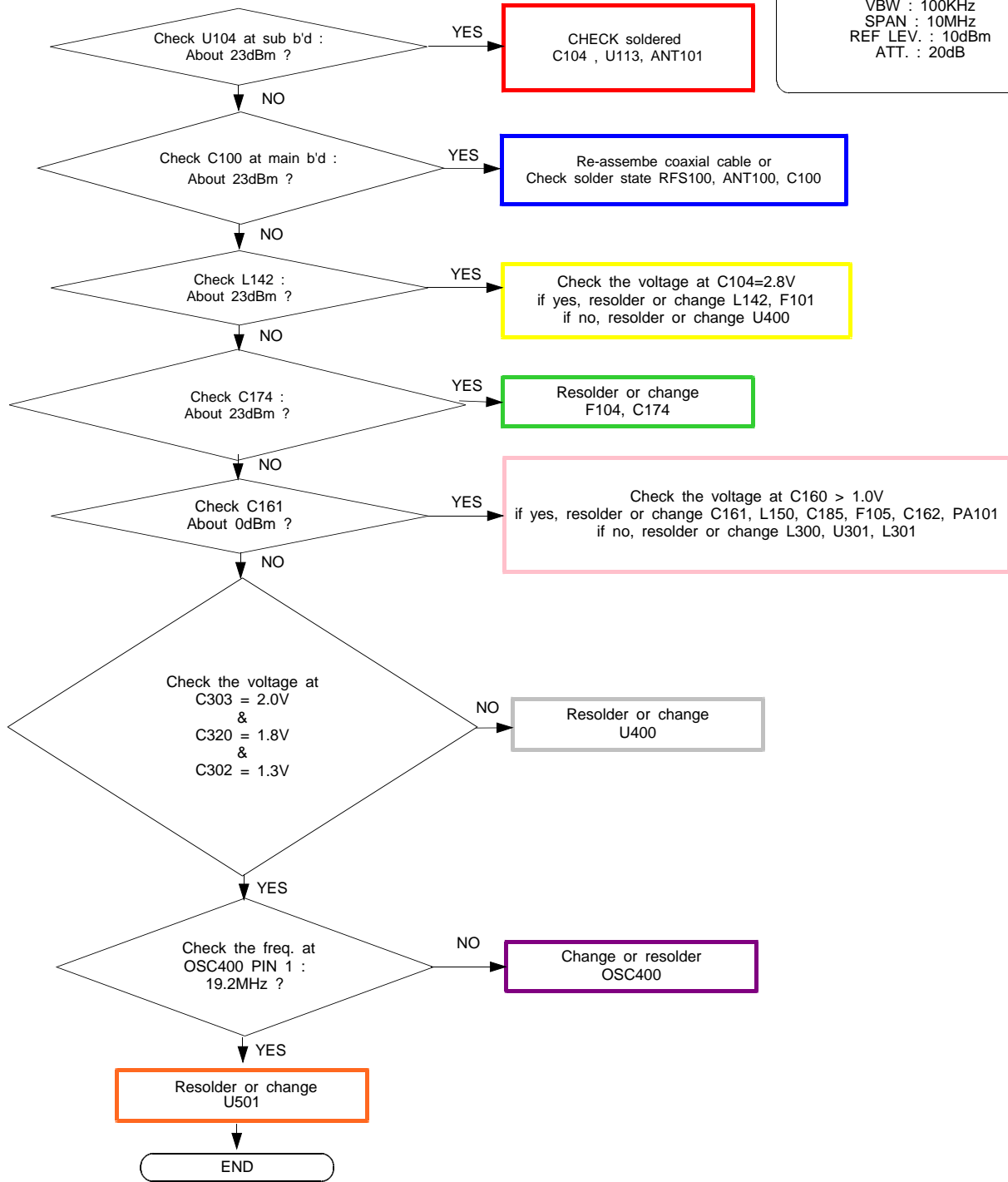

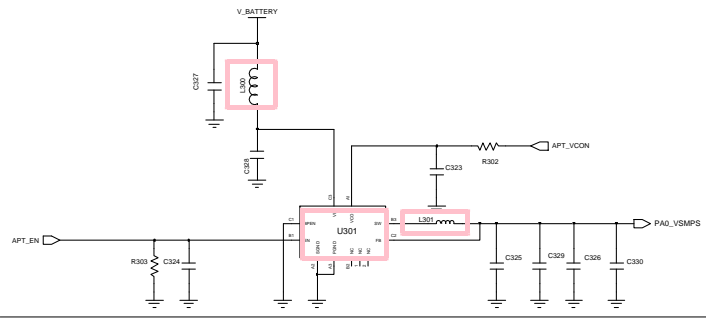
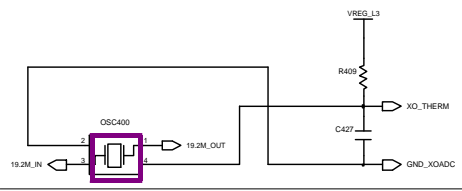
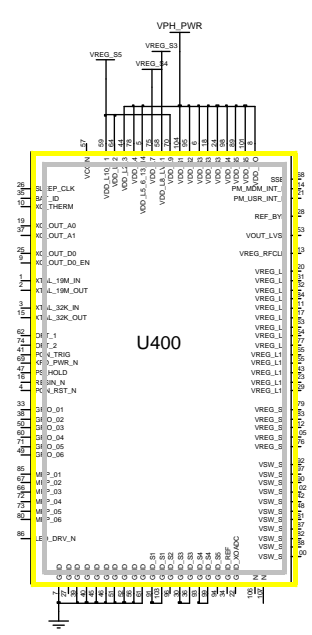
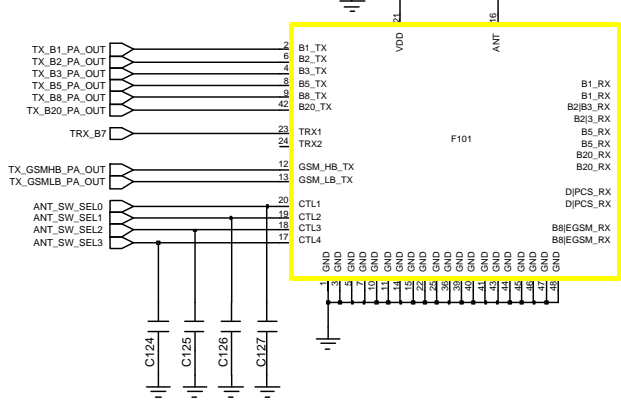
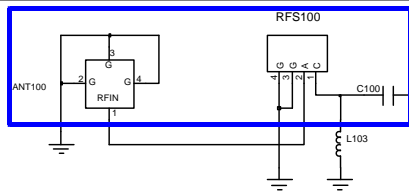
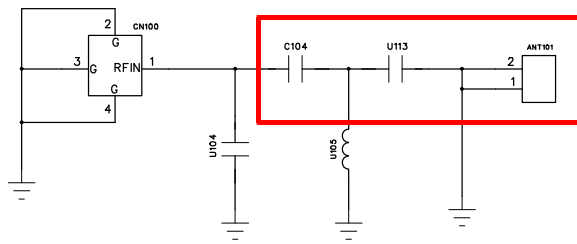

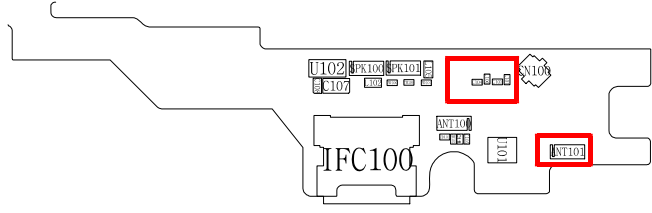
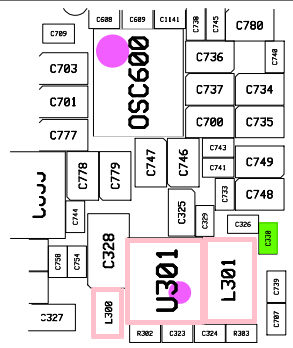
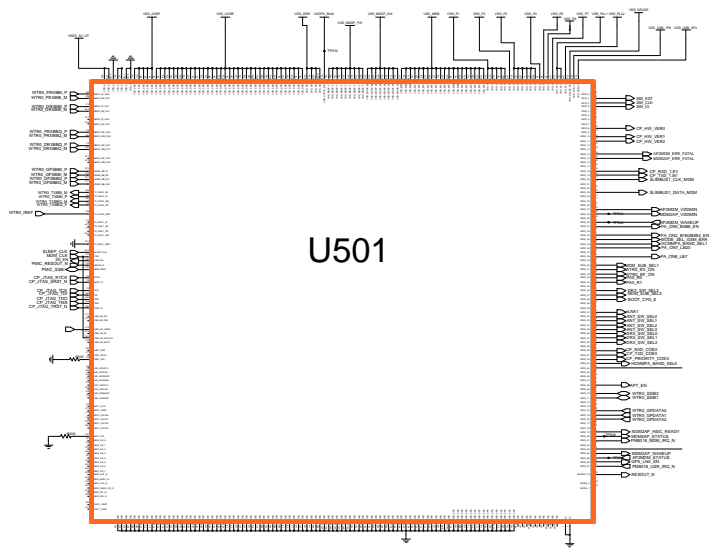
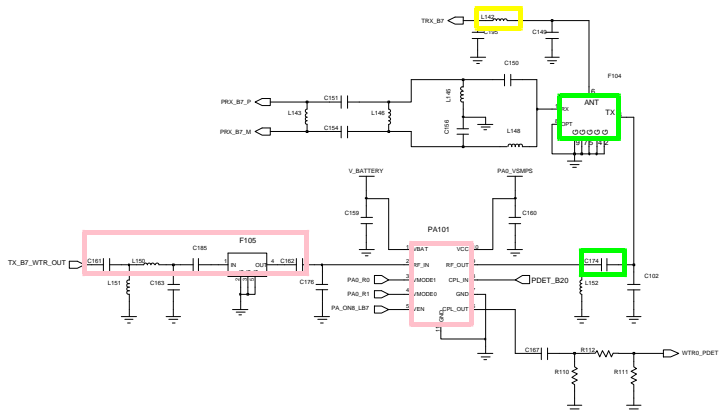

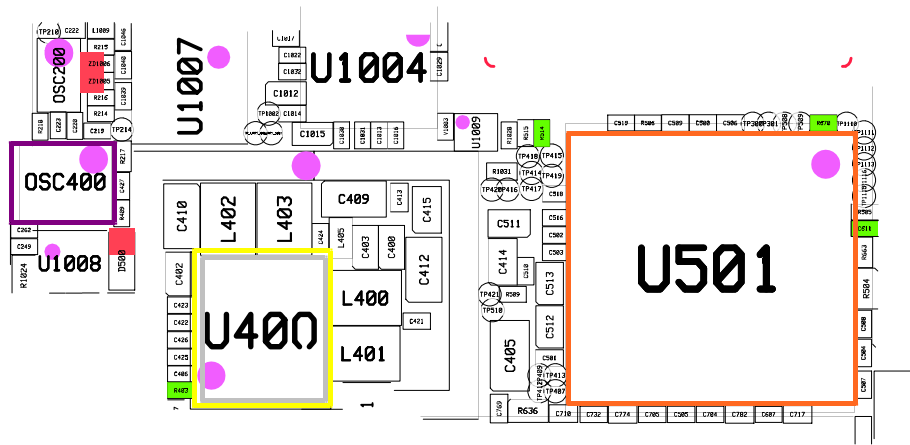
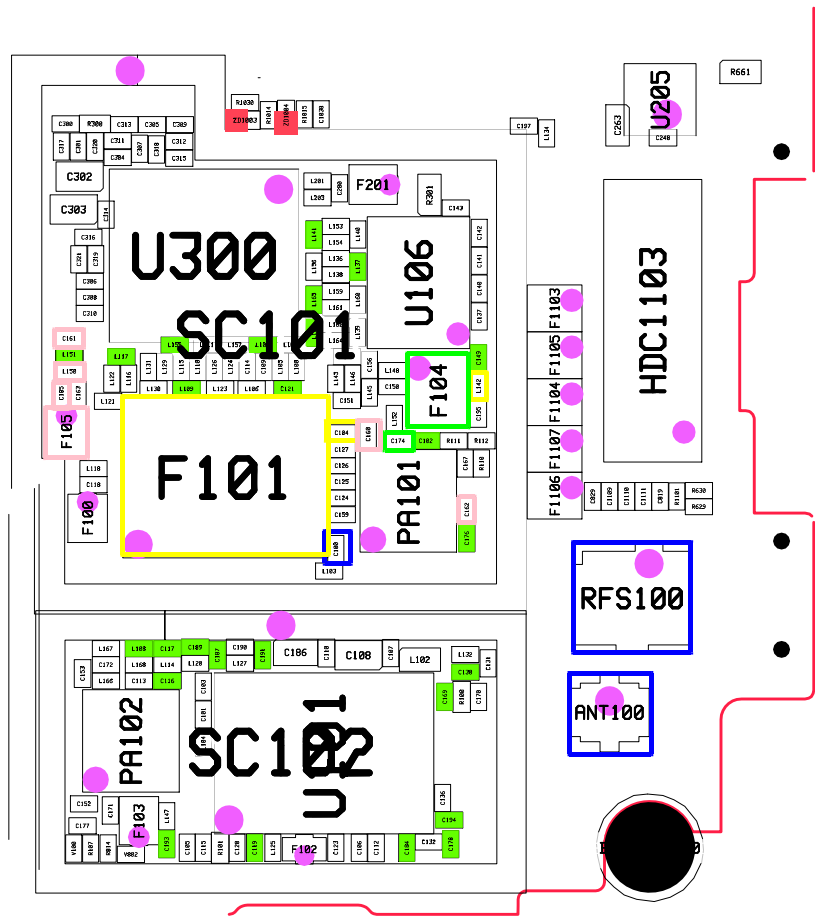

8-3-42. LTE Band20 TX

CONTINUOUS TX ON CONDITION APPLIED
 LTE Band7 CH : 20600
 RBW : 100KHz
 VBW : 100KHz
 SPAN : 10MHz
 REF LEV. : 10dBm
 ATT. : 20dB

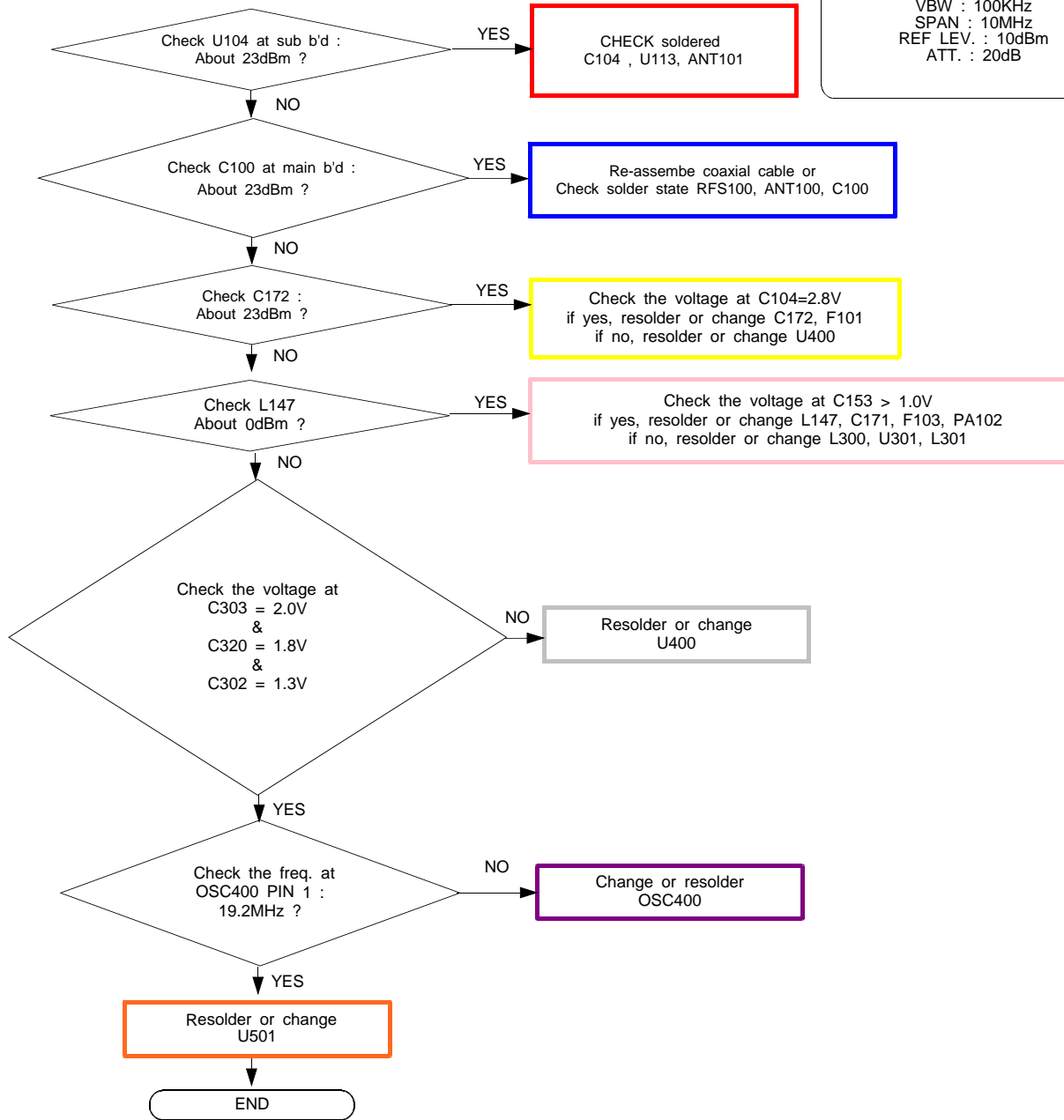

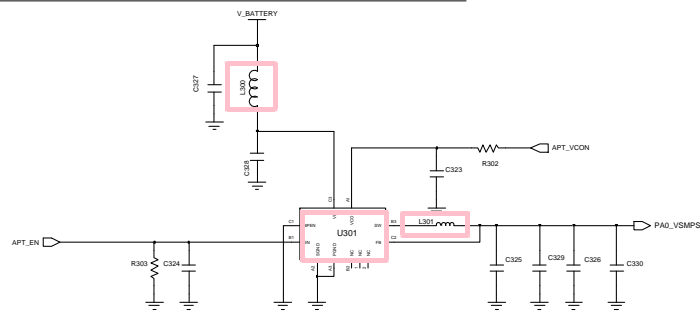
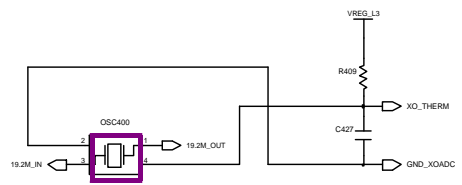
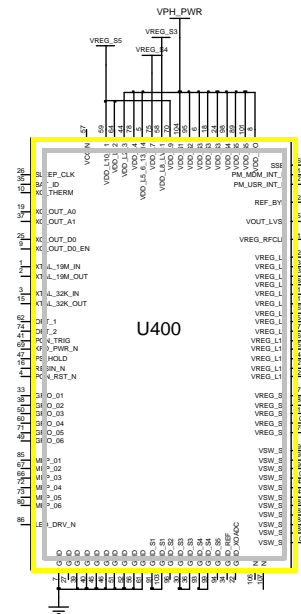
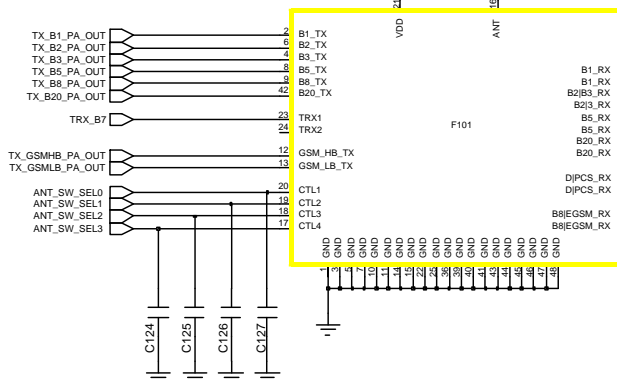
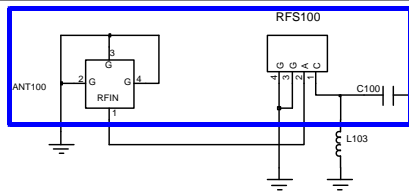
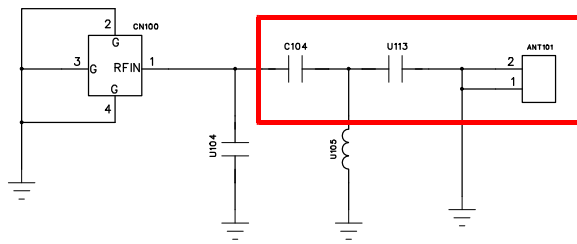

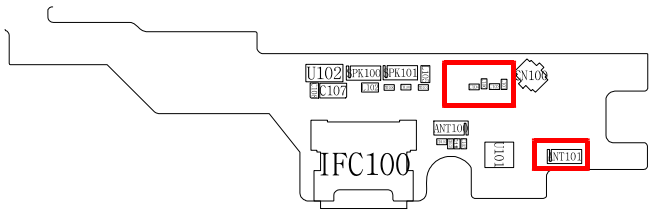
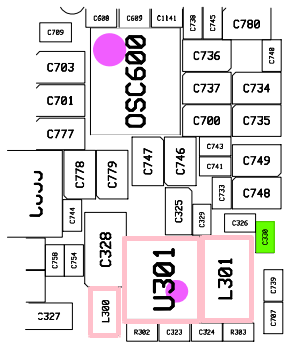
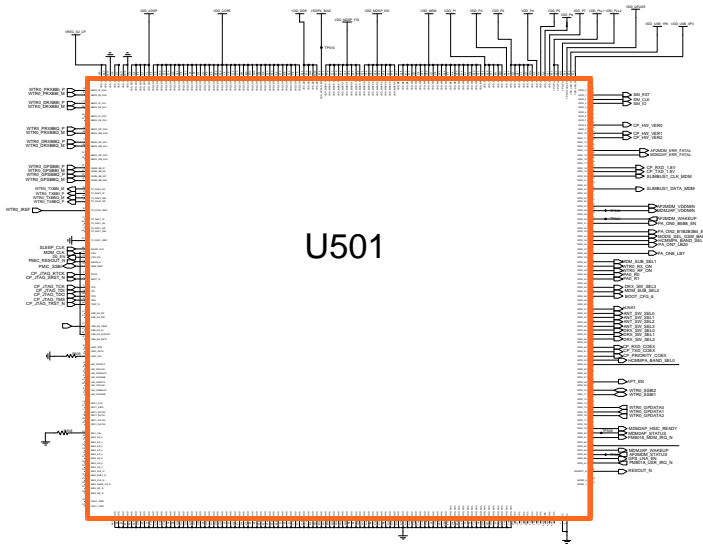
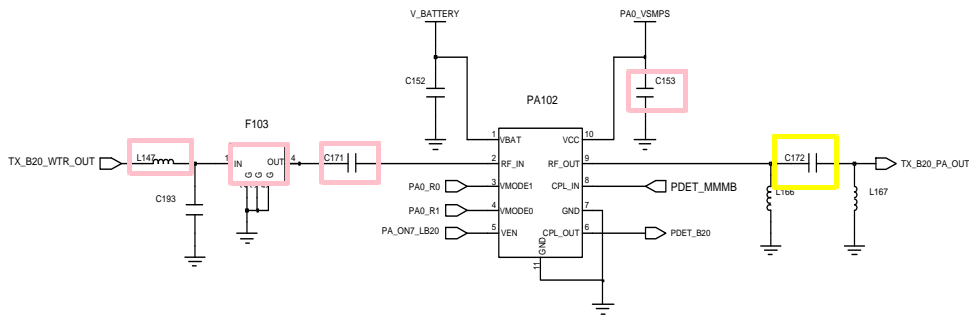

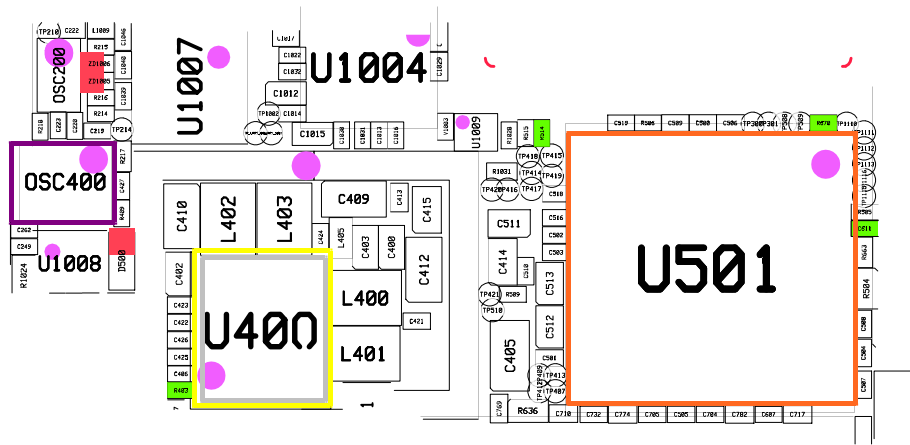
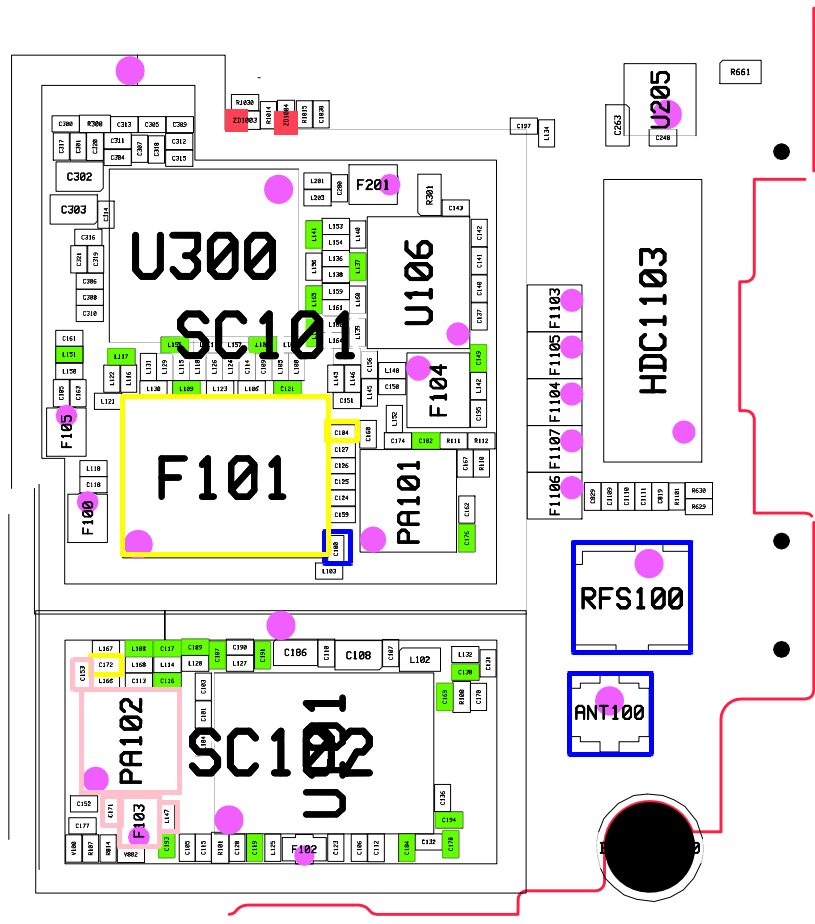

8-4. Service Schematics

- NC Point(Top View)

●: NC

	1	2	3	4	5	6	7
A	○	○	○	○	○	○	○
B	○	○	○	○	○	○	○
C	○	○	○	○	○	○	○
D	○	○	○	○	○	○	○
E	○	○	○	○	○	○	○
F	○	○	○	○	○	○	○
G	○	●	○	○	○	○	○

U202

	1	2	3	4	5	6	7	8	9	10	11	12	13	14	15	16	17
A	○		○		○		○		○		○		○		○		○
B		○		○		○		○		○		○		○		○	
C	○		○		○				○						○		○
D		○				○		○		○		○		○		○	
E	○		○		○		○		○								○
F		○		○		○		○		○				○		○	
G					○				○				○		○		○
H		○		○				○		○				○		○	
J	○		○		○				○		○		○				○
K		○		○		○		○		○		○		○		○	
L	○		○		○		○		○		○		○		○		○
M		○		○		○		○		○		○		○		○	●
N	○		○		○		○		○		○		○		○		○
P		○		○		○		○		○		○		○		○	
R	○		○		○		○		○		○		○		○		○
T		○		○				○		○		○		○		○	
U	○		○				○		○				○		○		○
V		○		○				○		○			○		○		○
W	○		○		○		○		○		○		○		○		○

U301

	1	2	3	4	5	6	7	8	9	10	11	12	13	14
A	●	●	○	○	○	○	○	●	●	●	●	●	●	●
B	●	○	○	○	○	○	●	●	●	●	●	●	●	●
C	●	○	●	○	○	○	●	●	●	●	●	●	●	●
D	●	●	●	●								●	●	●
E	●	●	●		○	○	○	○	○	○		●	●	●
F	●	●	●		○					○		●	●	●
G	●	●	○		○					○		●	●	●
H	●	●	●		○					○		●	●	●
J	●	●	●		○					○		●	●	●
K	●	●	●		○	○	○	○	○	○		●	●	●
L	●	●	●									●	●	●
M	●	●	●	○	○	○	●	●	●	●	●	●	●	●
N	●	○	●	○	○	●	●	●	●	●	●	●	●	●
P	●	●	○	○	○	○	○	●	●	○	●	●	●	●

UME600

	1	2	3	4	5	6	7	8	9	10
A	●	○	○	○	○	○	○	○	○	○
B	○	○	○	○	○	○	○	○	○	○
C	○	○	○	○	○	○	○	○	○	○
D	○	○	○	○	○	○	○	○	○	○
E	○	○	○	○	○	○	○	○	○	○
F	○	○	○	○	○	○	○	○	○	○
G	○	○	●	○	○	○	○	○	○	○
H	○	○	○	○	○	○	○	○	○	○
J	●	○	○	○	○	○	○	○	○	○

U903

	1	2	3	4	5	6
A	○	○	○	○	○	○
B	○	○	○	○	○	○
C	○	○	●	●	○	○
D	○	○	●	●	○	○
E	○	○	○	○	○	○
F	○	○	○	○	○	○

U1007

	1	2	3	4	5	6	7
A	○	○	○	○	●	●	○
B	○	○	○	○	○	○	○
C	○	○	○	○	○	○	○
D	○	○	○	○	○	○	○
E	○	○	○	○	○	○	○
F	○	○	○	○	○	○	○
G	○	○	○	○	○	○	○

U1109

	1	2	3	4	5	6	7	8	9	10	11	12	13	14	15	
A	●	○	○	○	○	○	○	○	○	○	○	○	○	○	○	●
B	○	○	○	○	○	○	○	○	○	○	○	○	○	○	○	○
C	○	○	○	○	○	○	○	○	○	○	○	○	○	○	○	○
D	○	○	○				○		○				○	○	○	
E	○	○	○										○	○	○	
F	○	○	○				○	○	○	○			○	○	○	
G	○	○	○				○		○	○			○	○	○	
H	○	○	○	○			○	○	○	○			○	○	○	
J	○	○	○	○			○	○	○	○			○	○	○	
K	○	○	○	○			○	○	○	○			○	○	○	
L	○	○	○				○	○	○	○			○	○	○	
M	○	○	○				○	○	○	○			○	○	○	
N	○	○	○										○	○	○	
P	○	○	○				○		○				○	○	○	
R	○	○	○	○	○	○	○	○	○	○	○	○	○	○	○	
Y	○	○	○	○	○	○	○	○	○	○	○	○	○	○	○	
U	●	○	○	○	○	○	○	○	○	○	○	○	○	○	○	●

U1110