

8. Level 3 Repair

8-1. Block Diagram

GT-N5110 BLOCK DIAGRAM

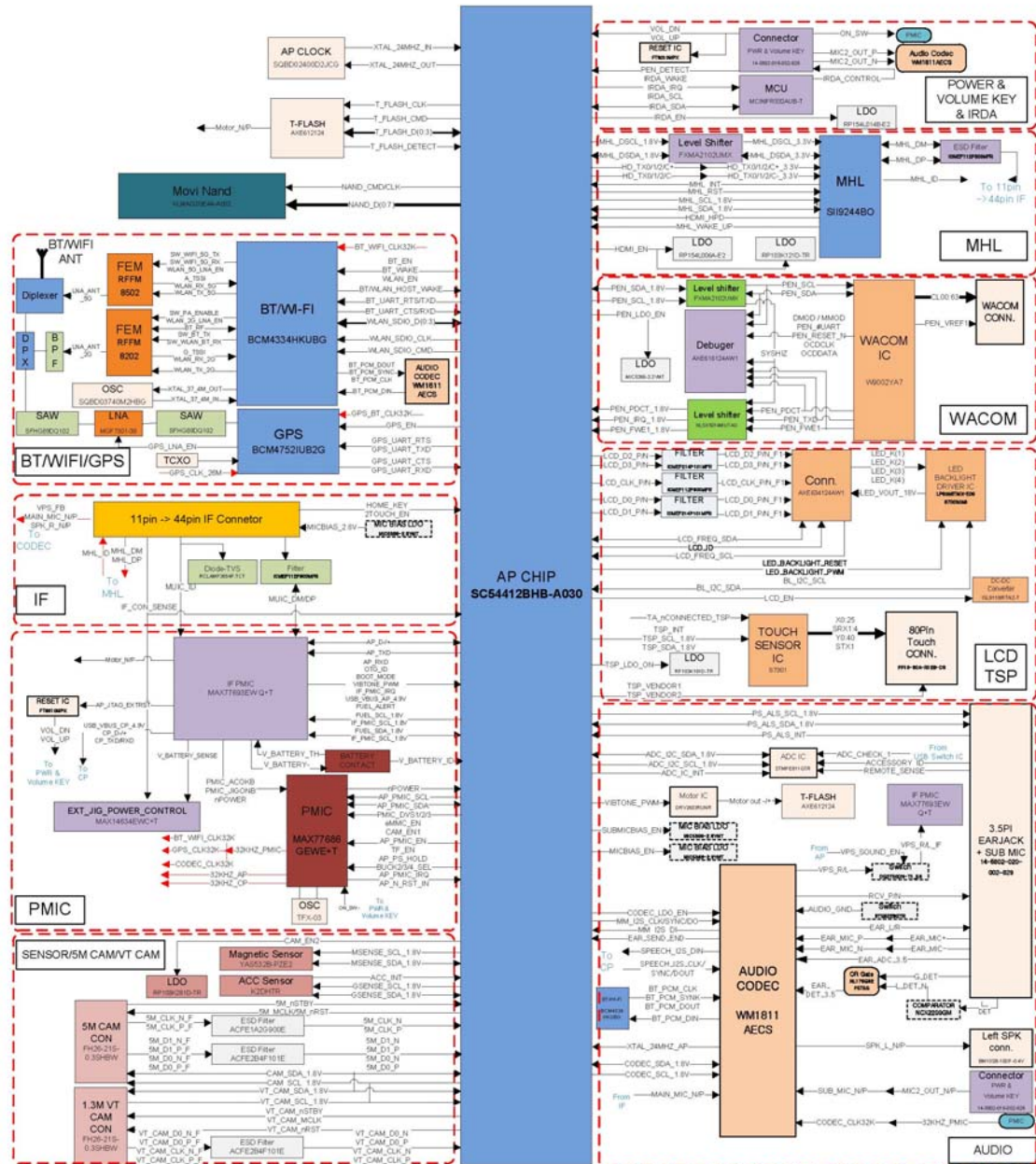

8-2. PCB Diagrams

8-2-1. Top

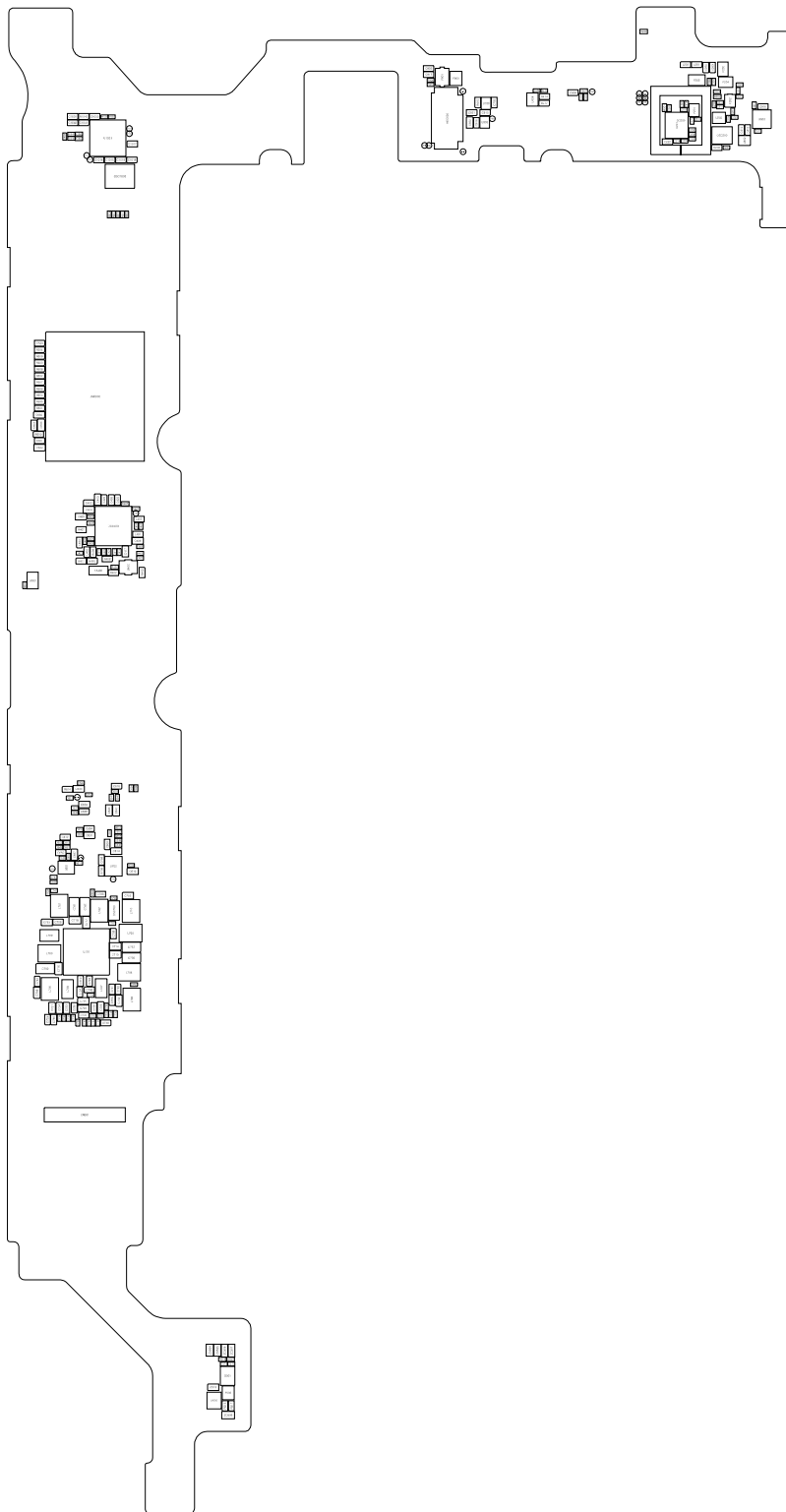

8-2-2. Bottom

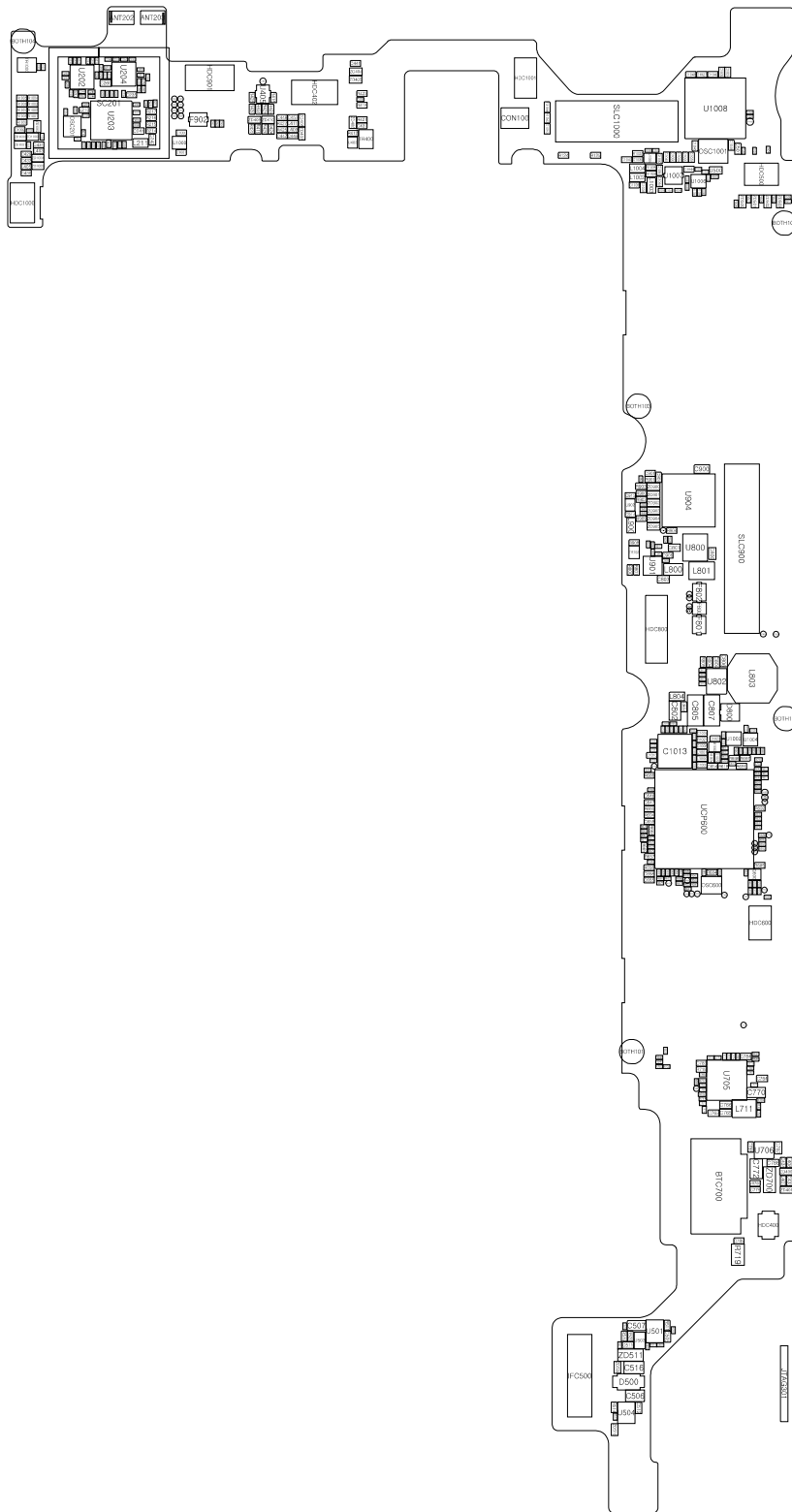

8-3. Flow Chart of Troubleshooting

Equipments

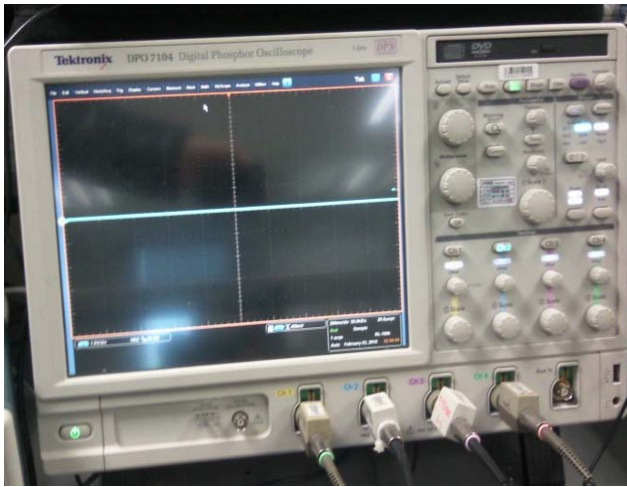

↑ Oscilloscope



↑ Digital Multimeter



↑ Power Supply



↑ + driver, ESD Safe Tweezer

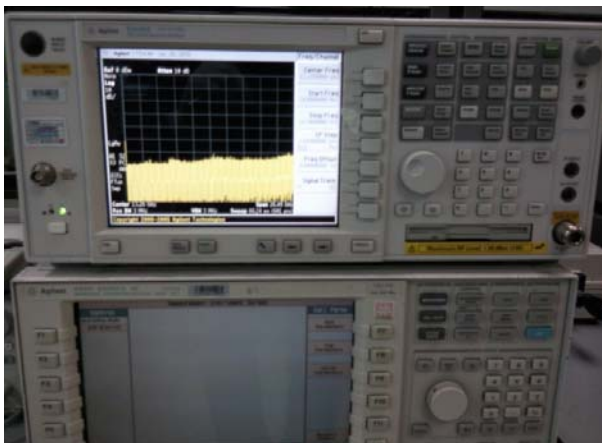

↑ 8960 & Spectrum Analyzer



↑ Soldering iron

8-3-1. Power On

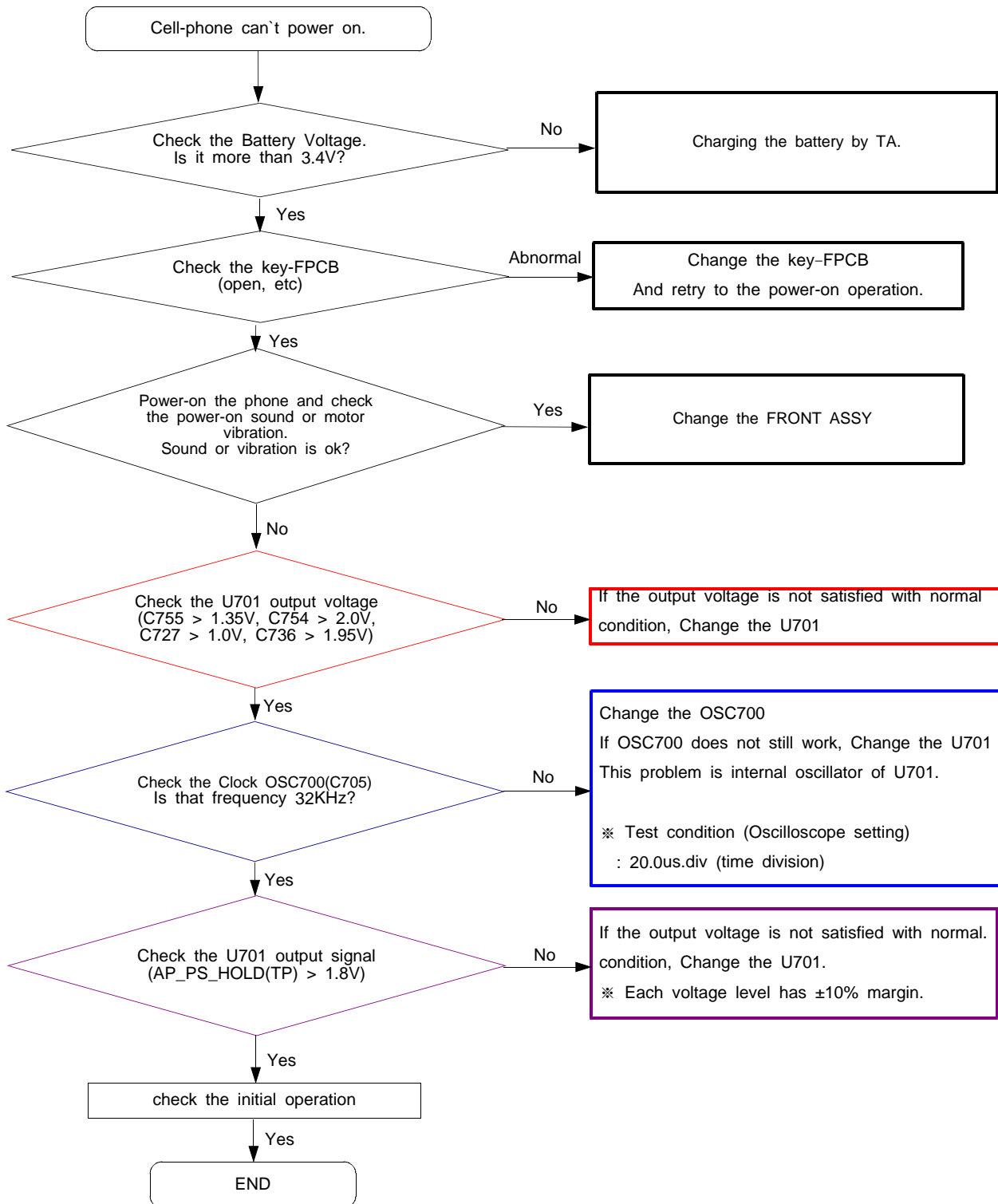

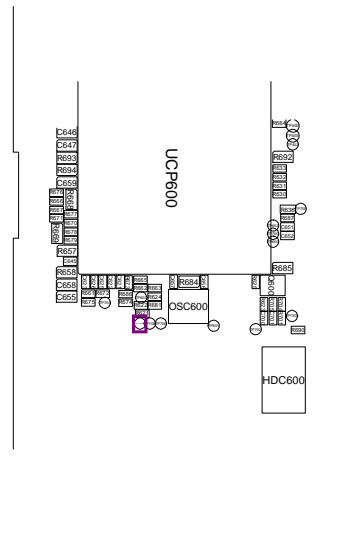
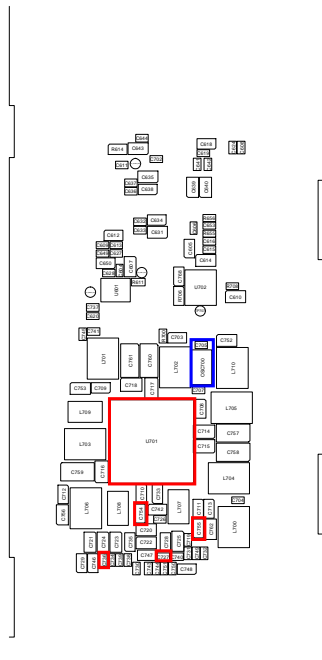
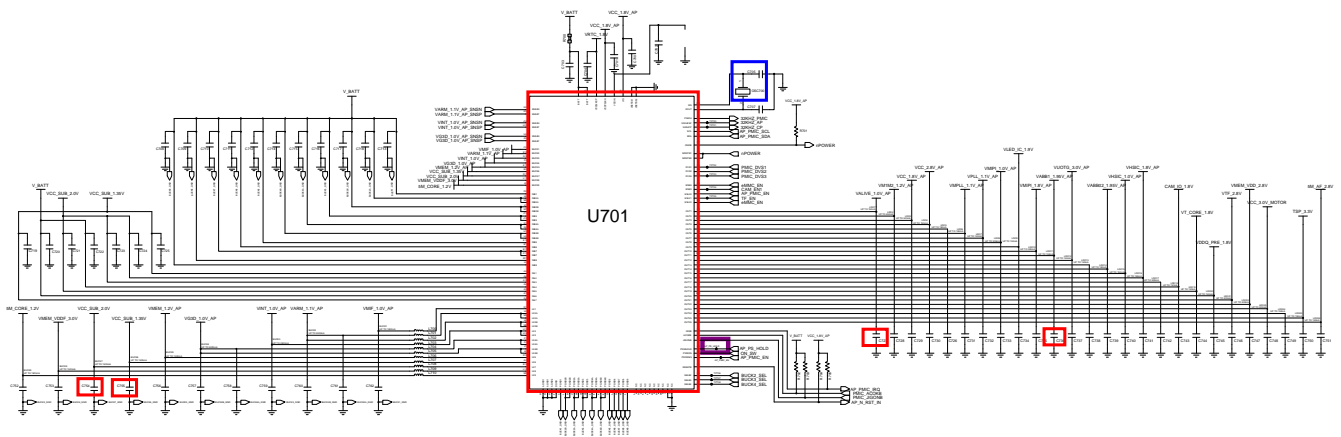

8-3-2. Initial

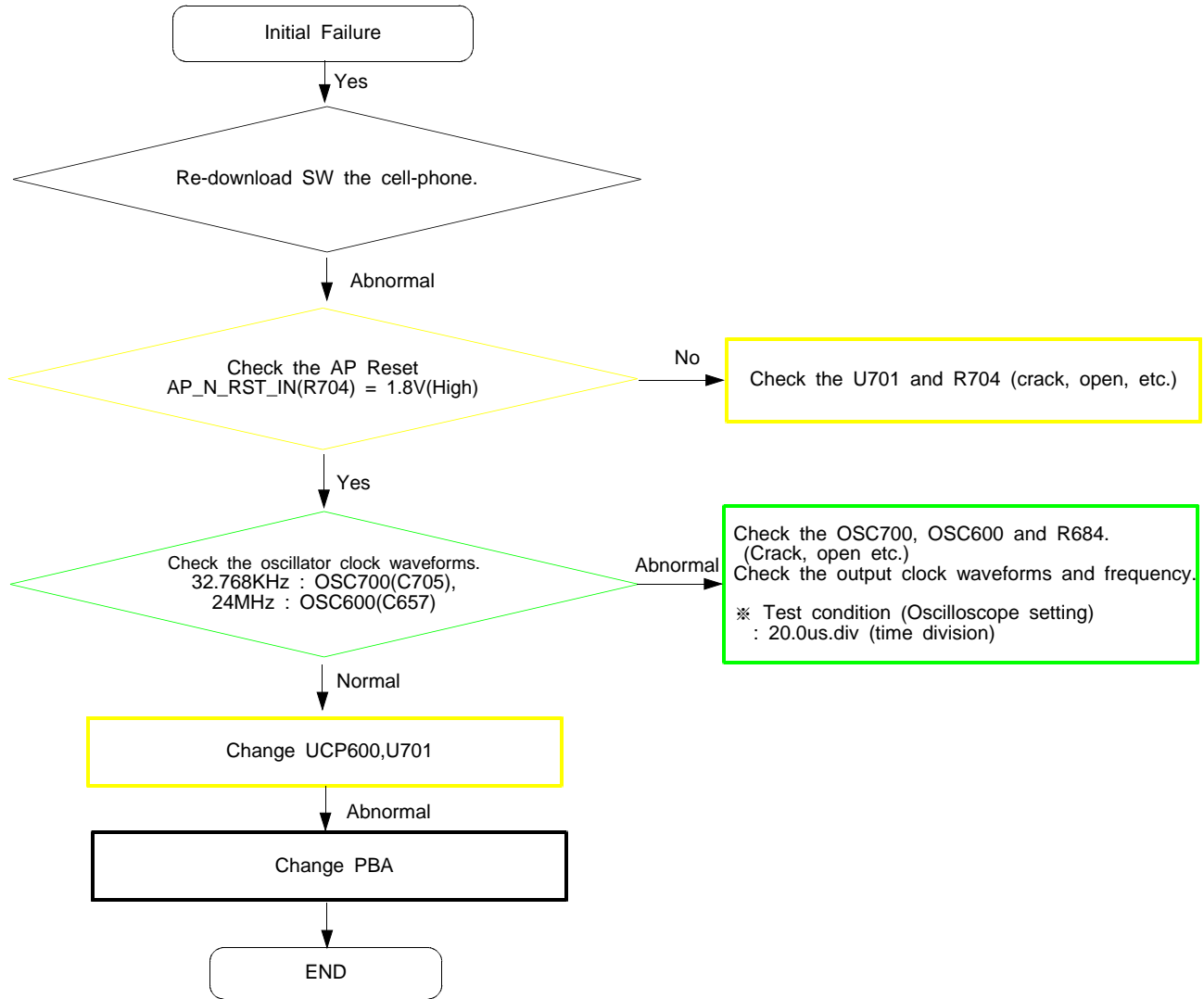

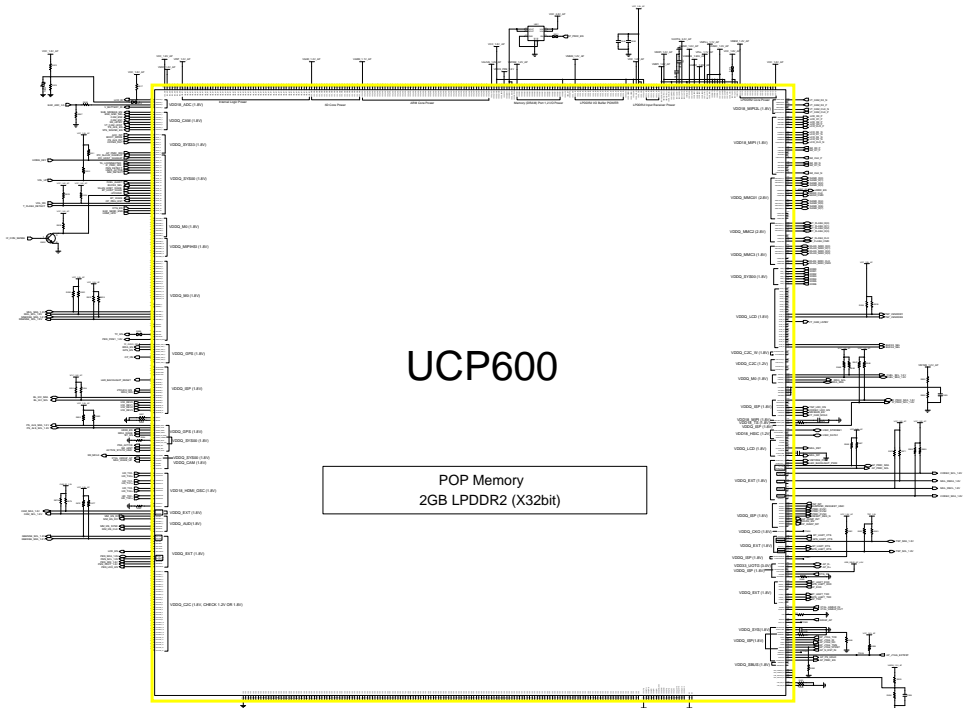
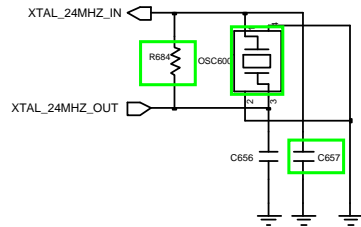
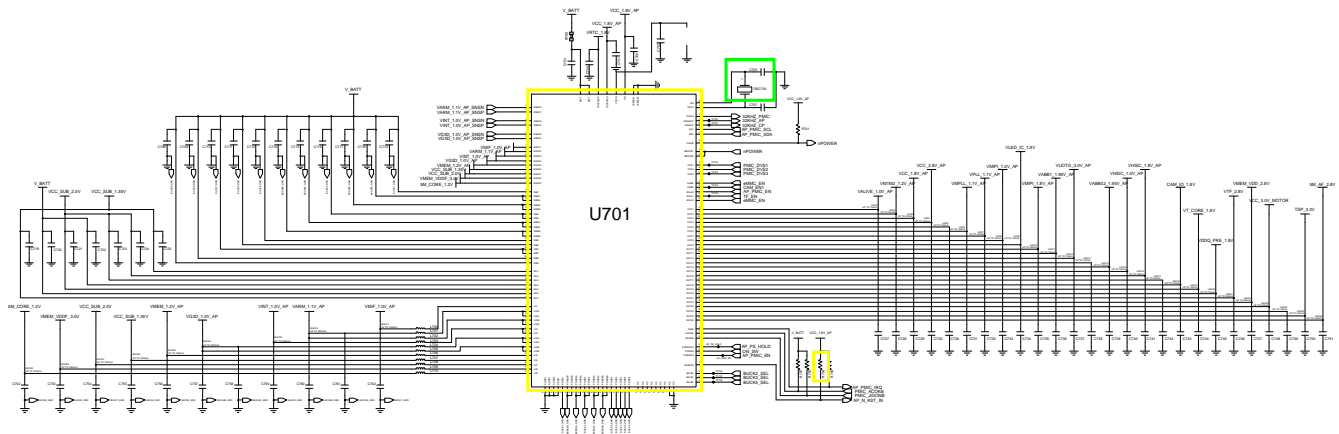

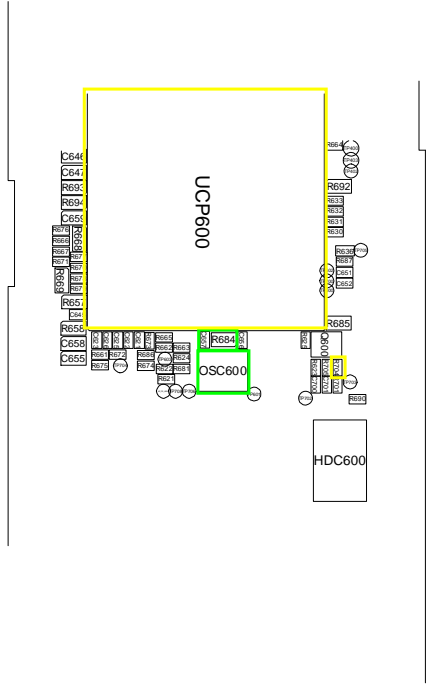
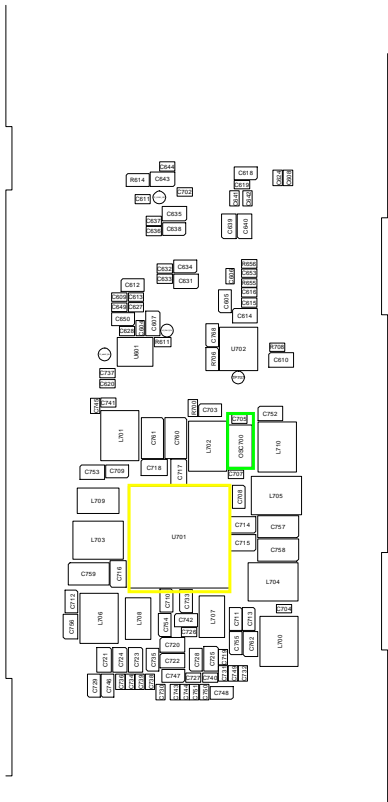

8-3-3. Charging Part

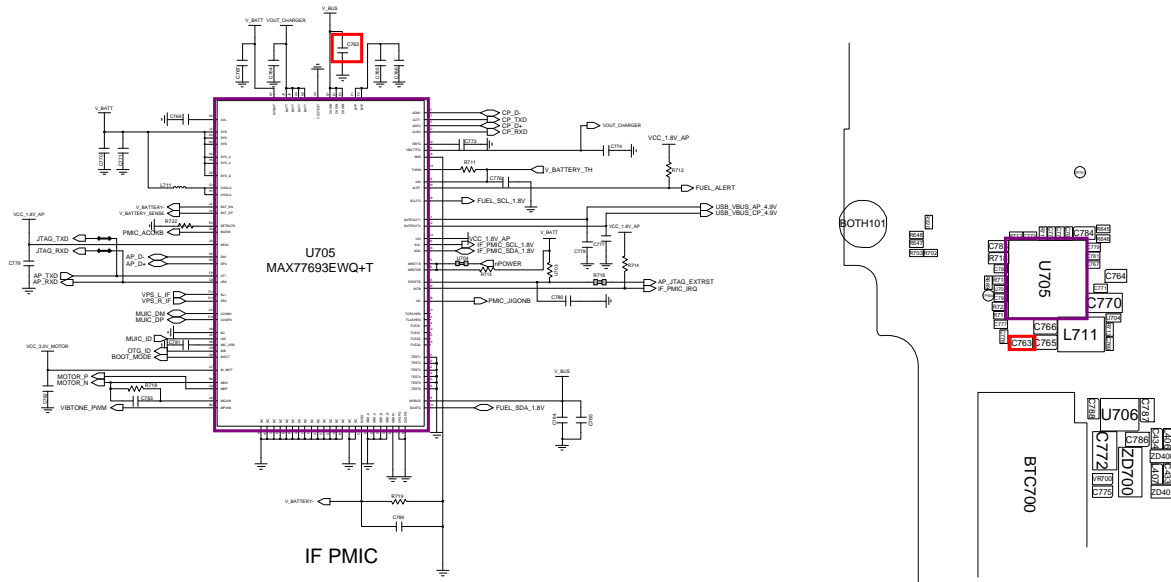
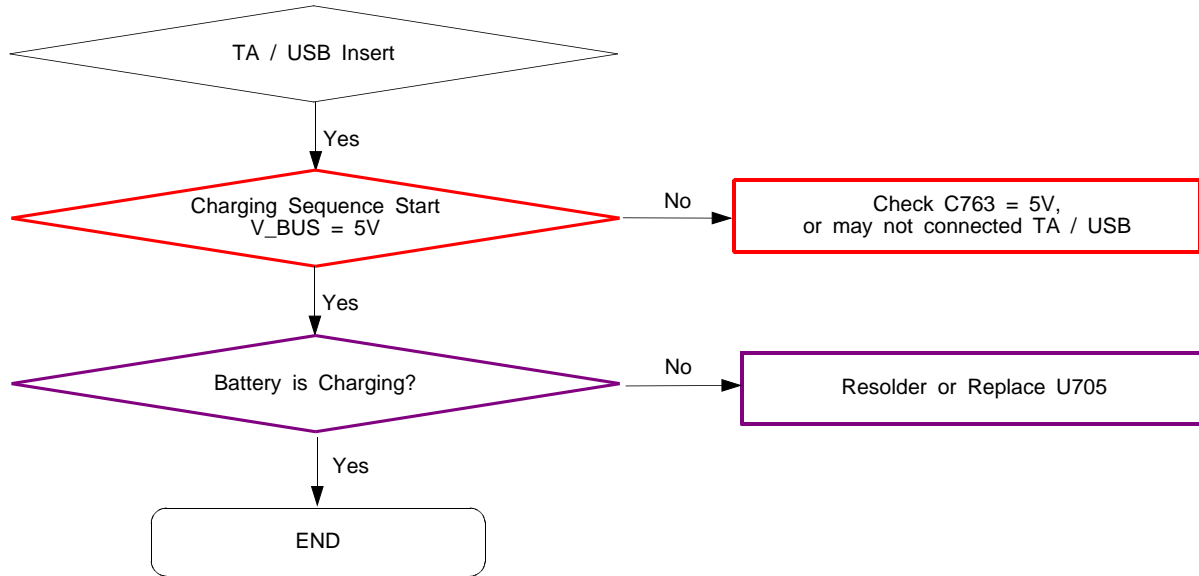

8-3-4. Microphone Part

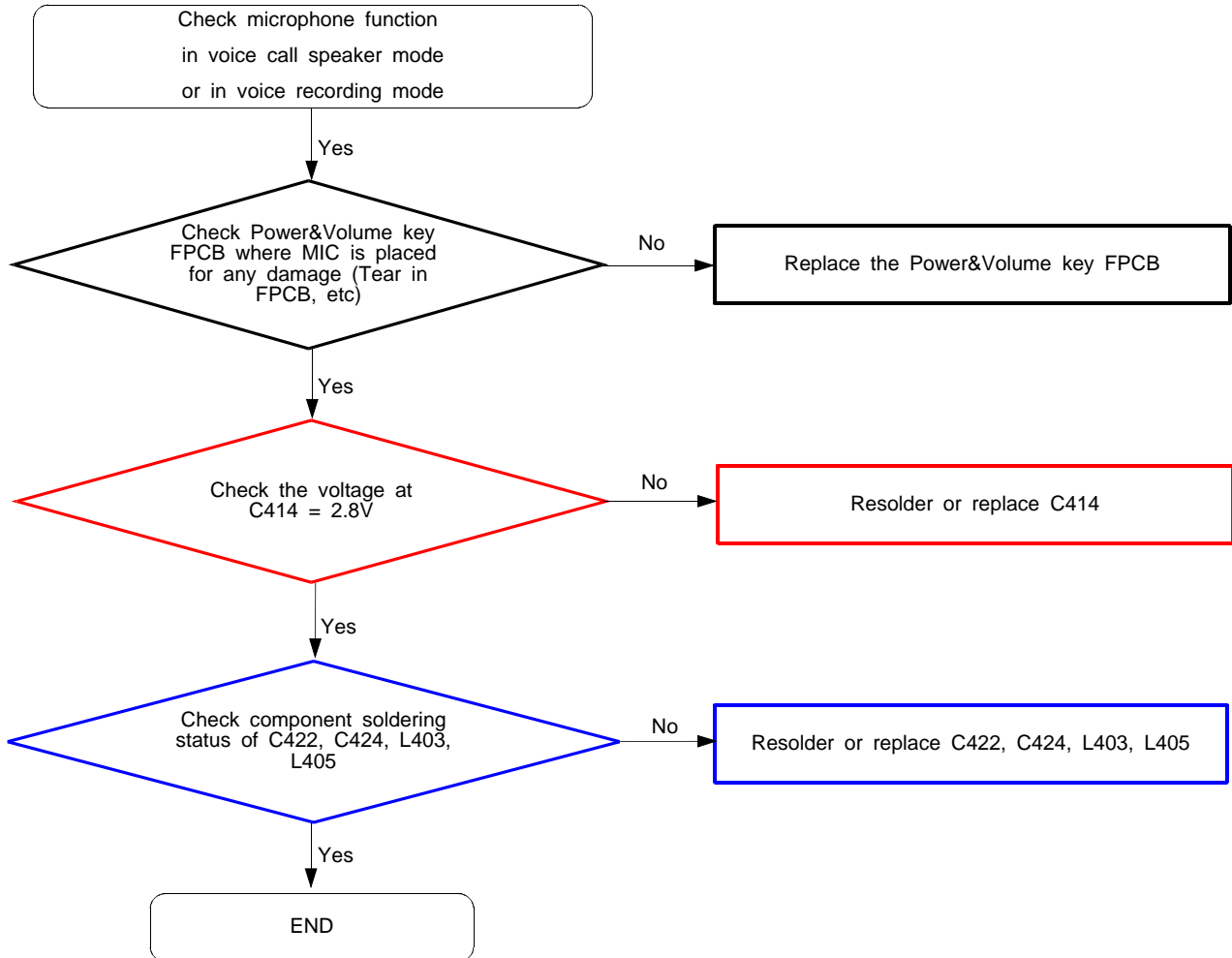

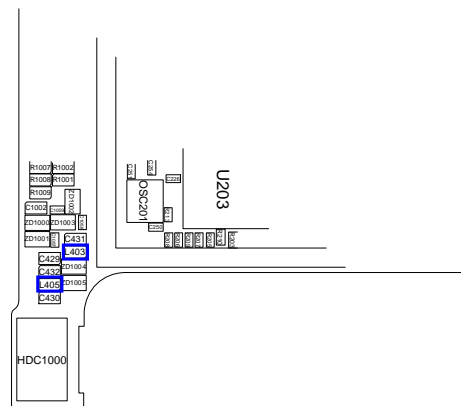
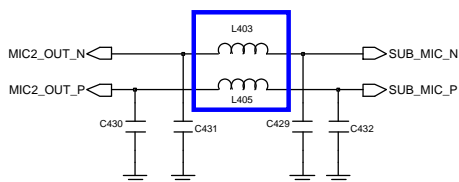
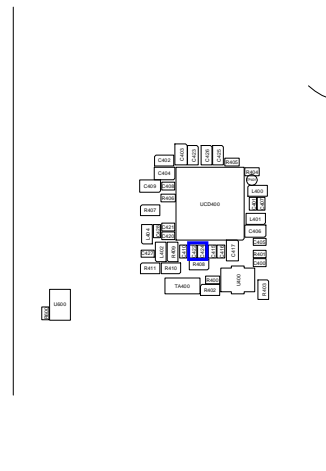
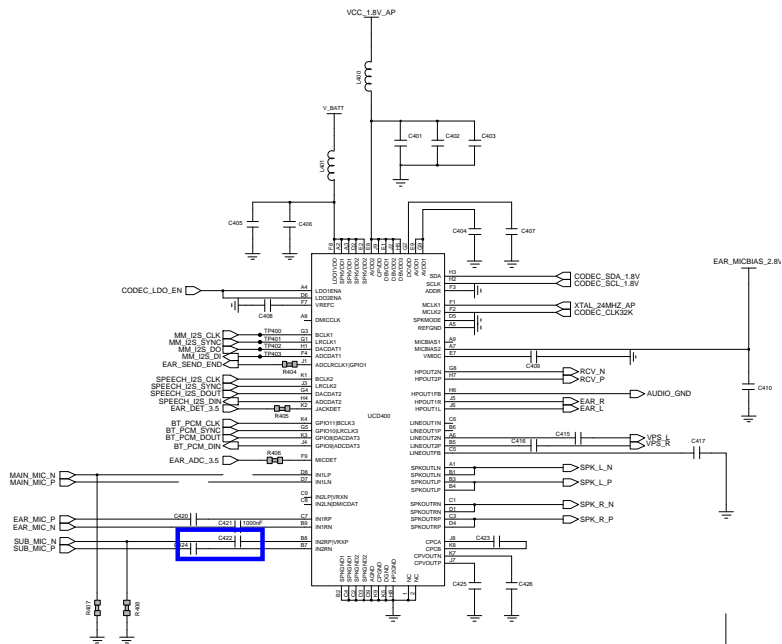
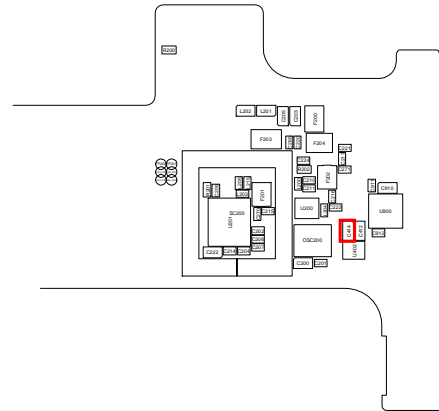
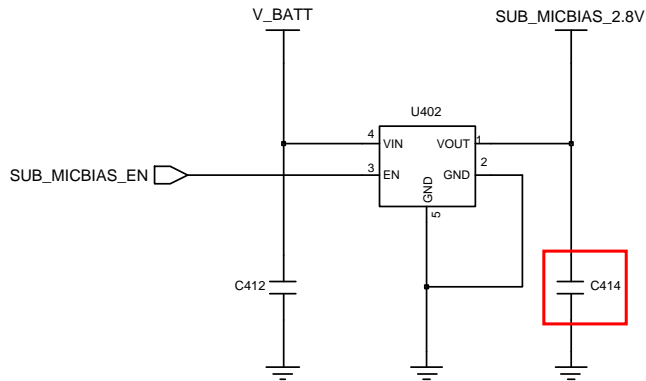

8-3-5. Speaker Part

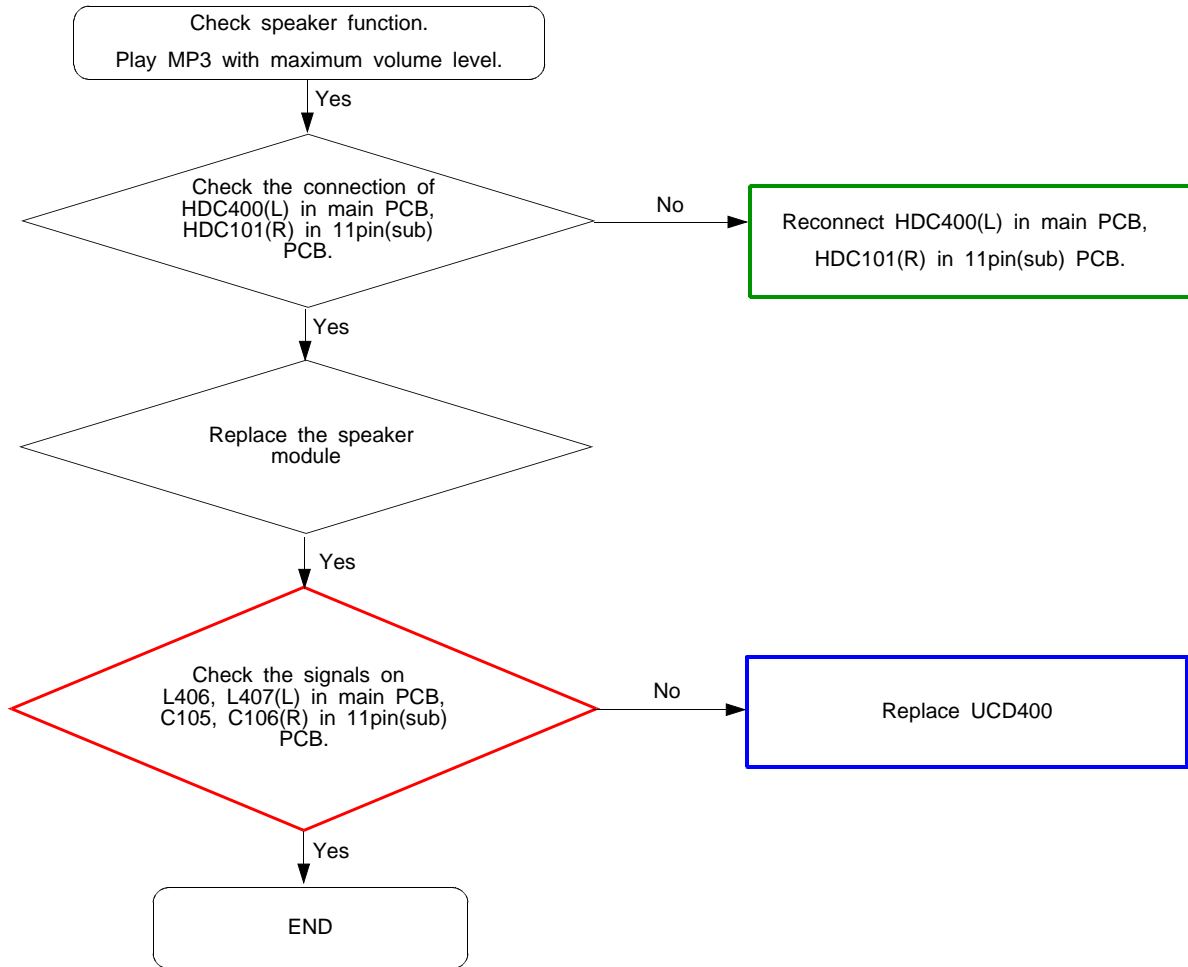

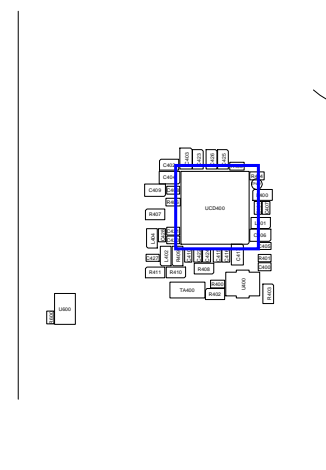
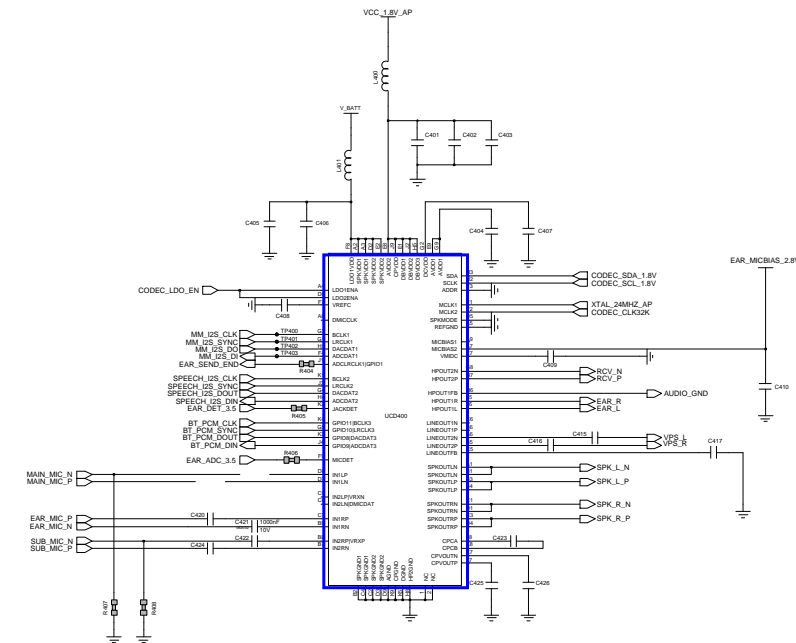
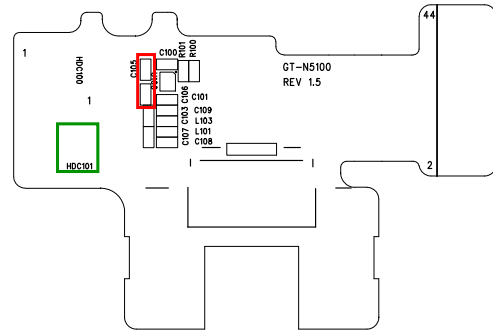
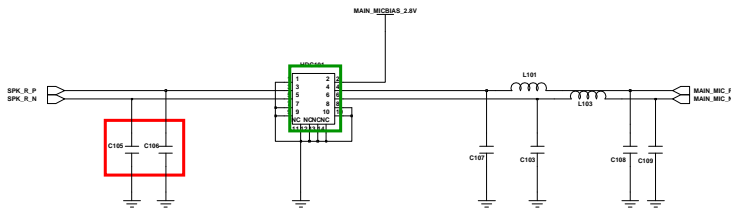
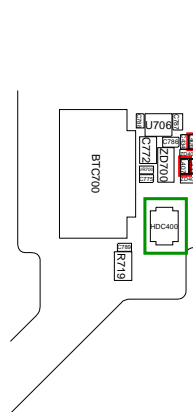
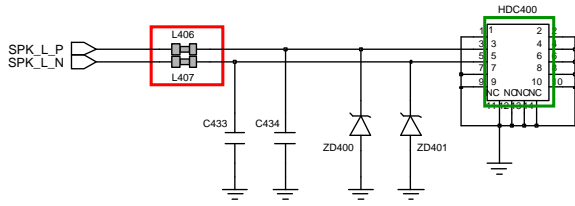

8-3-6. BT Part

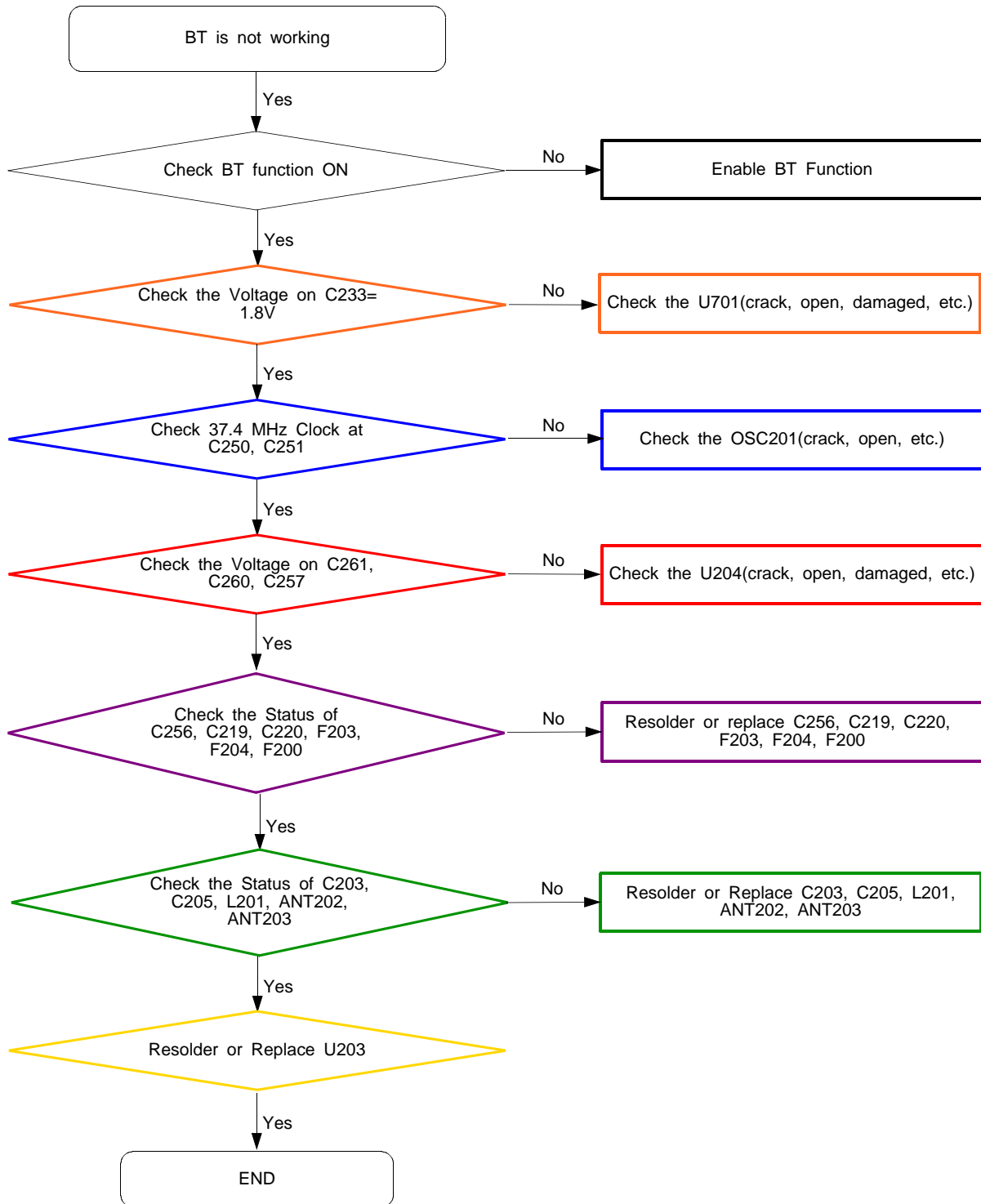

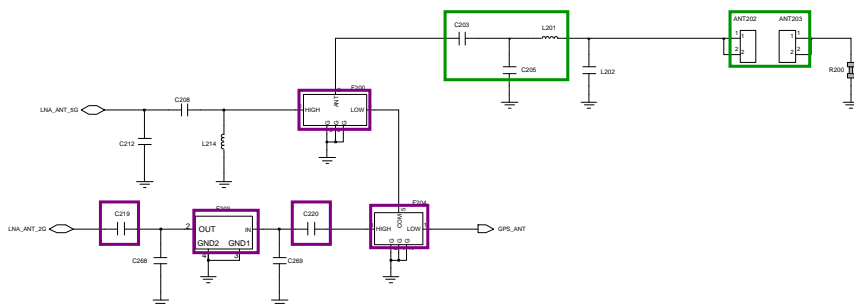
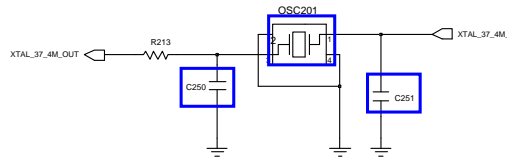
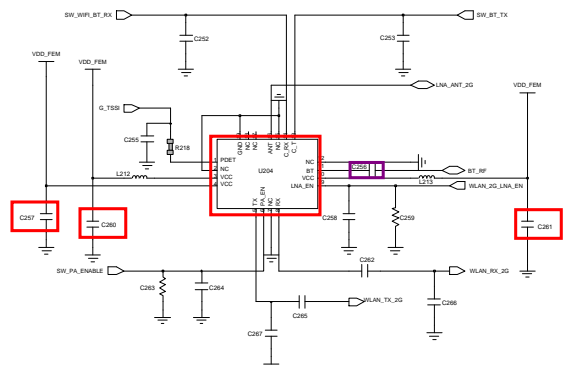
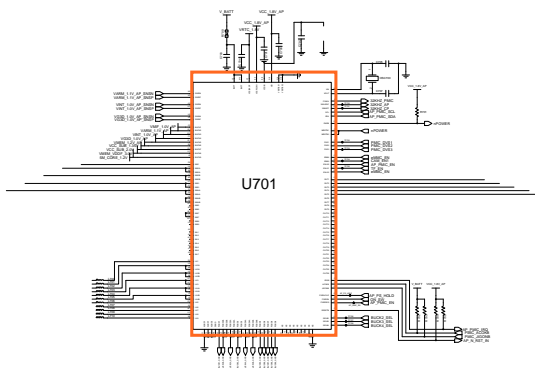
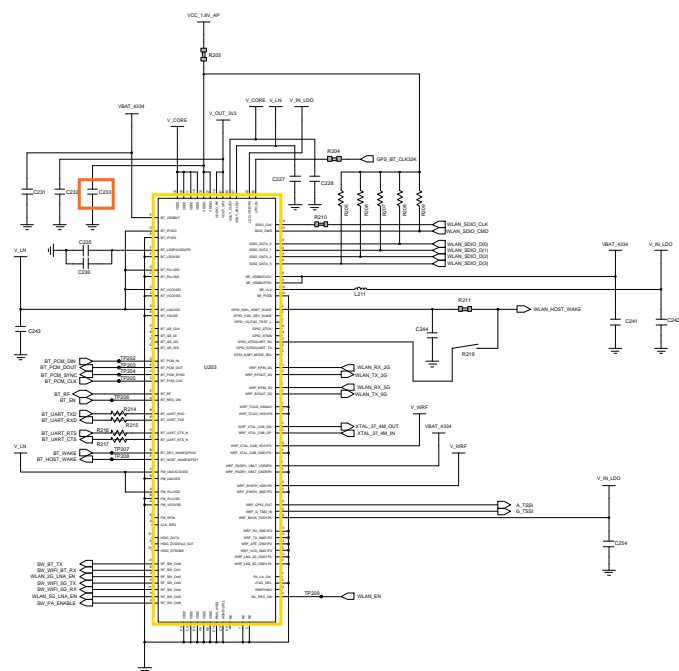

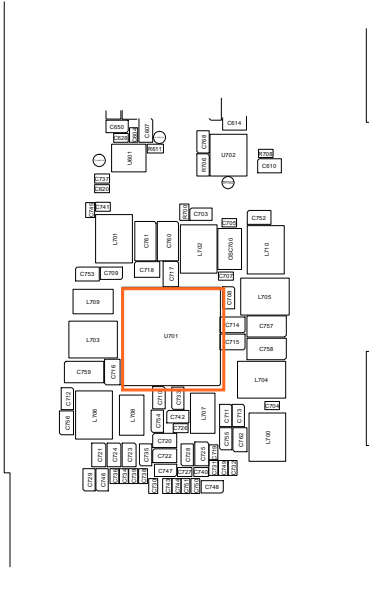
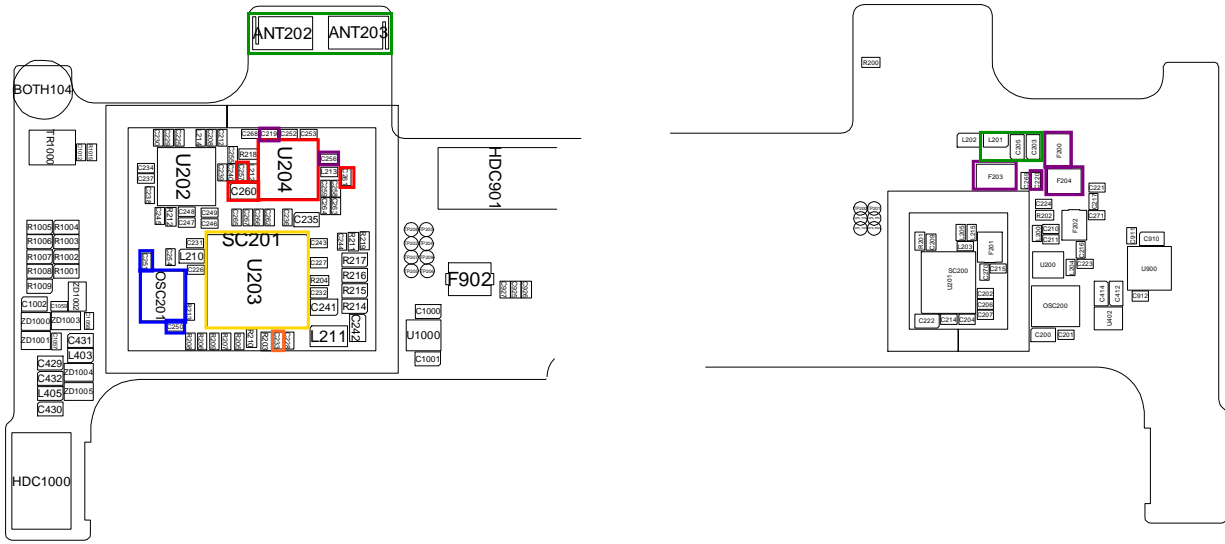

8-3-7. WIFI Part

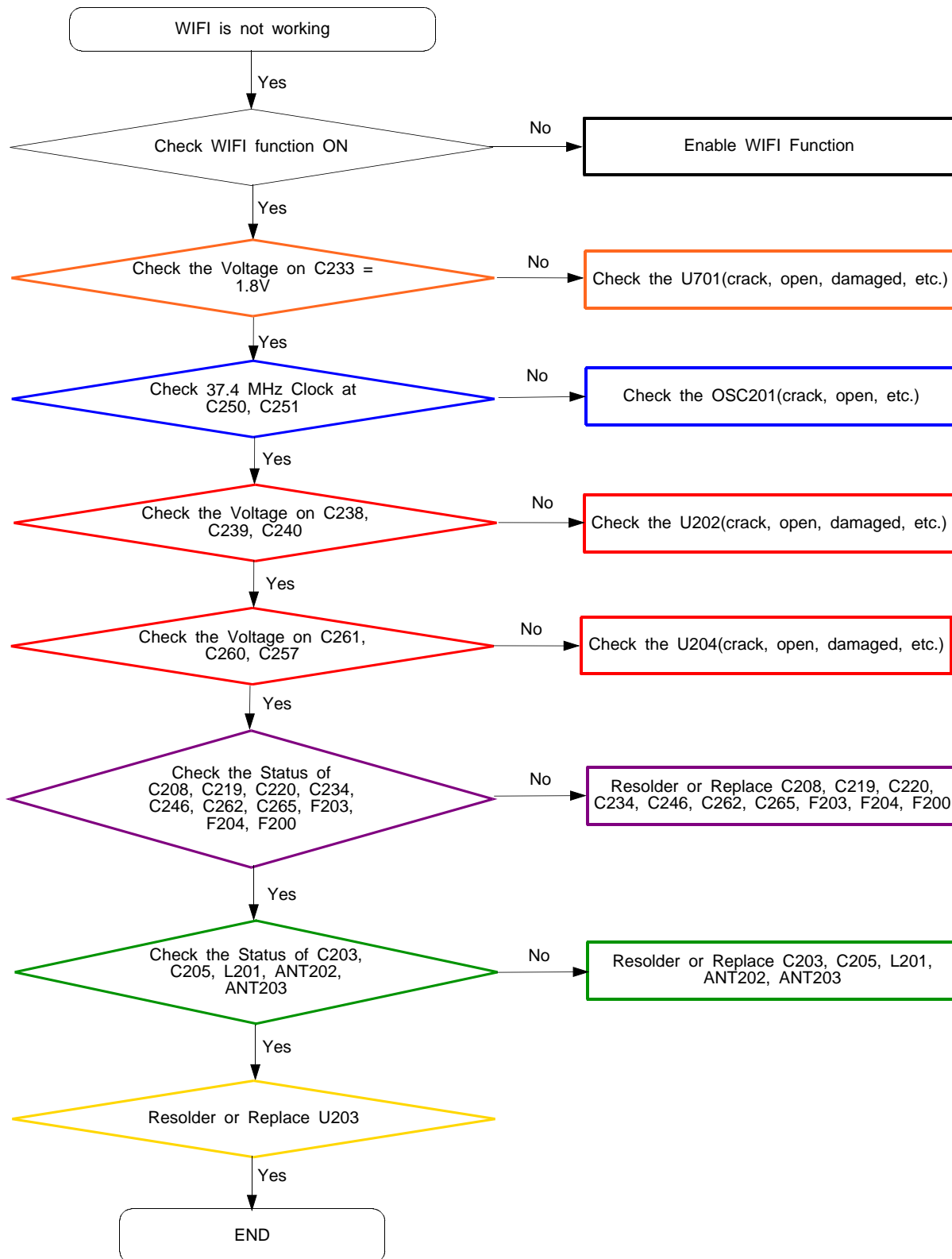

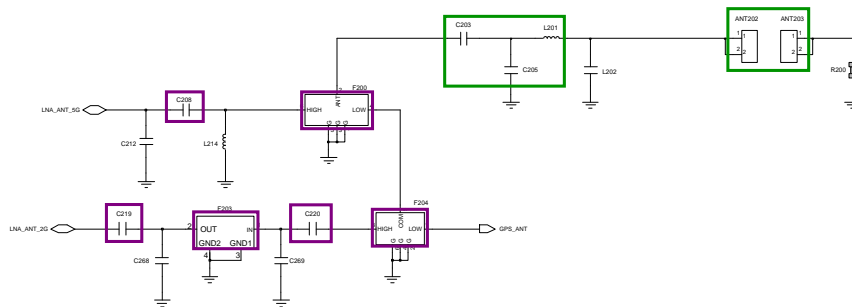
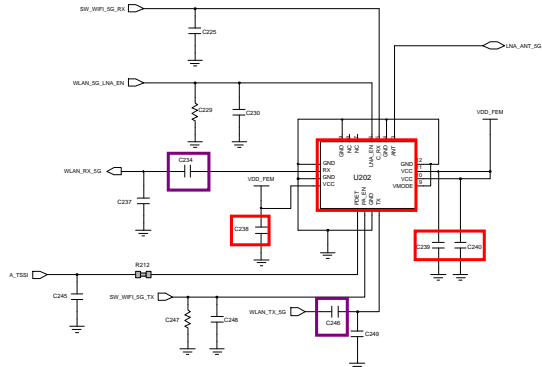
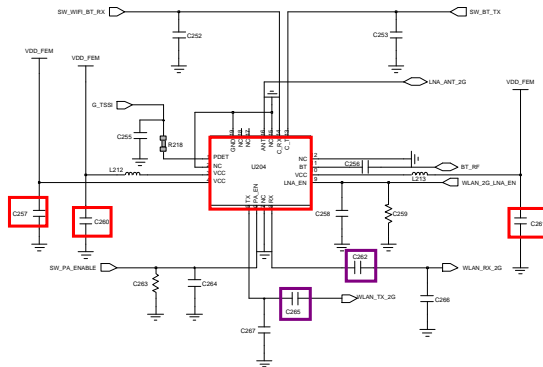
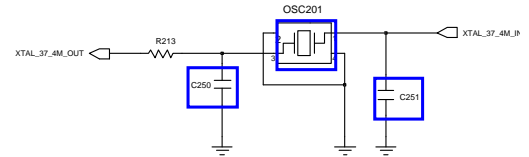
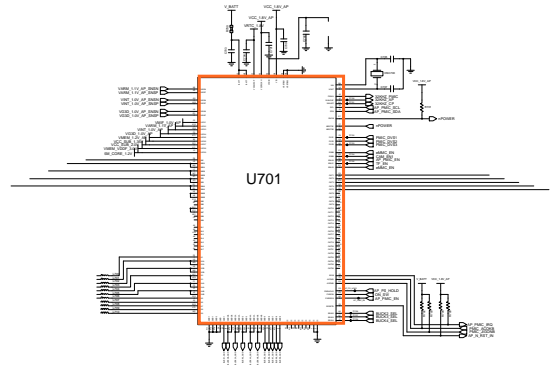
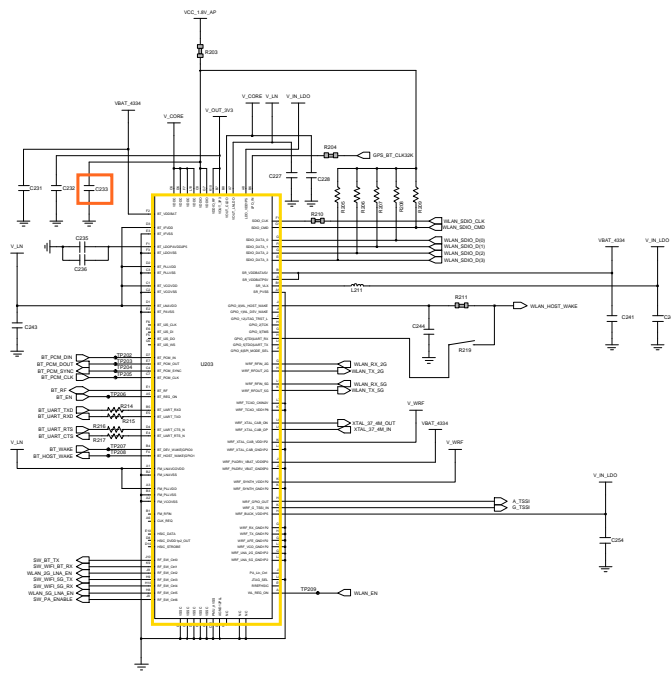

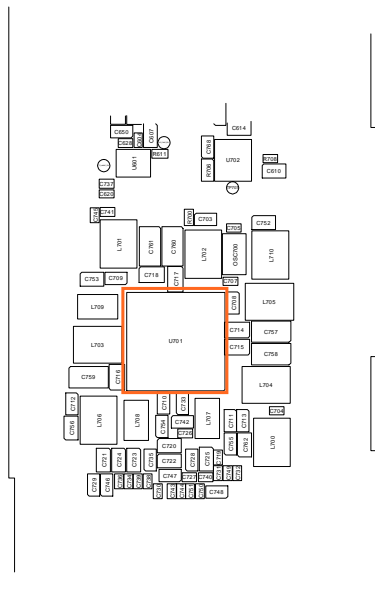

8-3-8. GPS Part

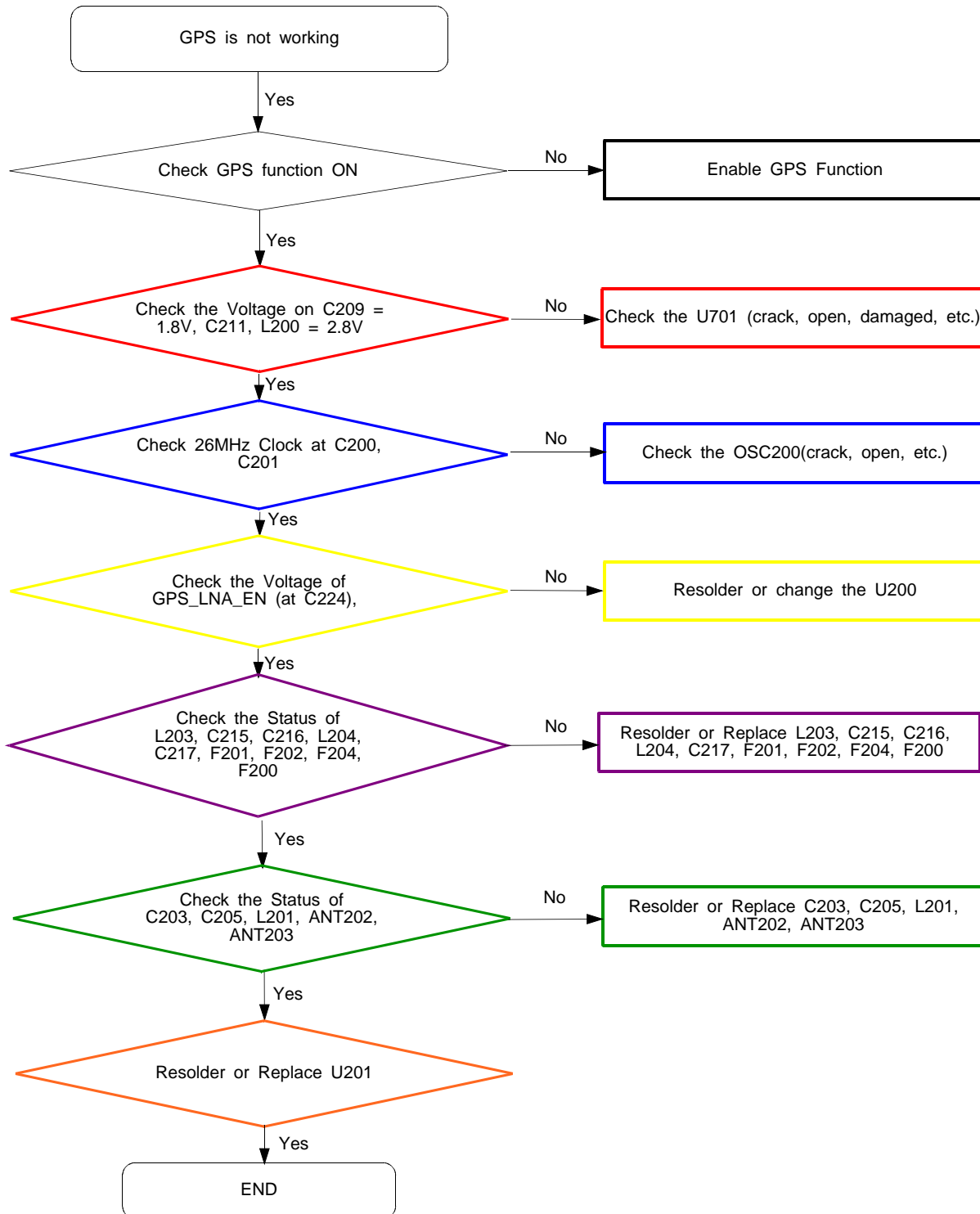

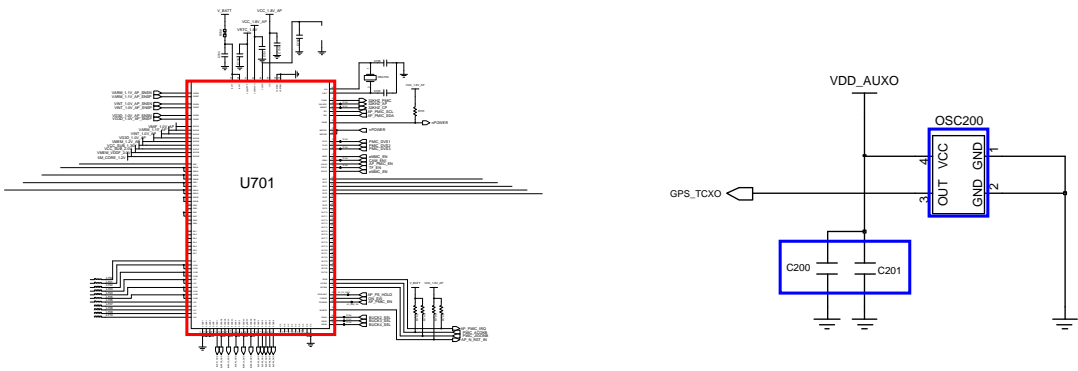
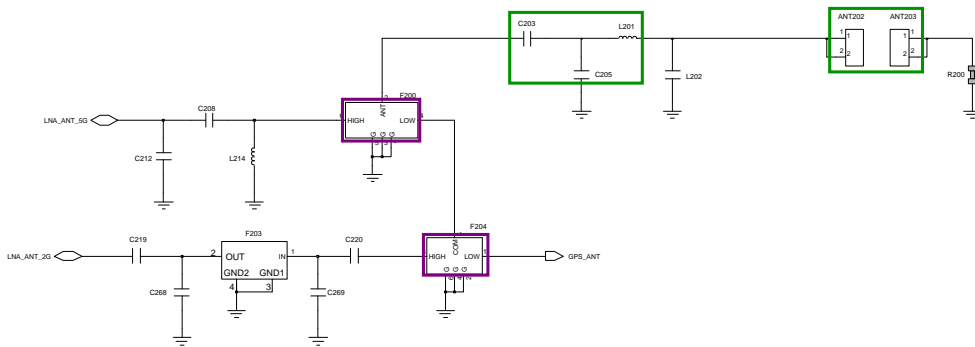
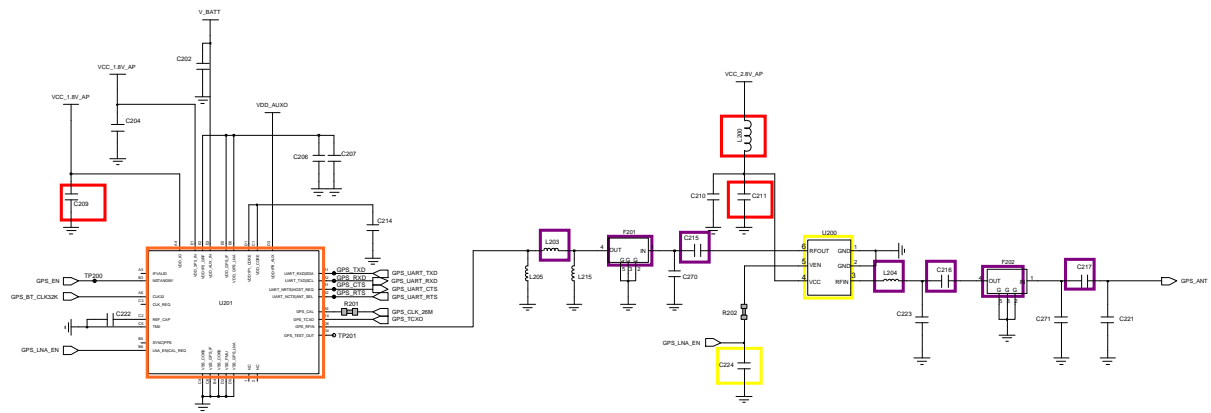

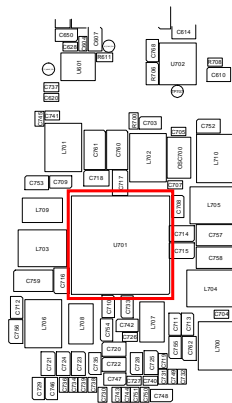
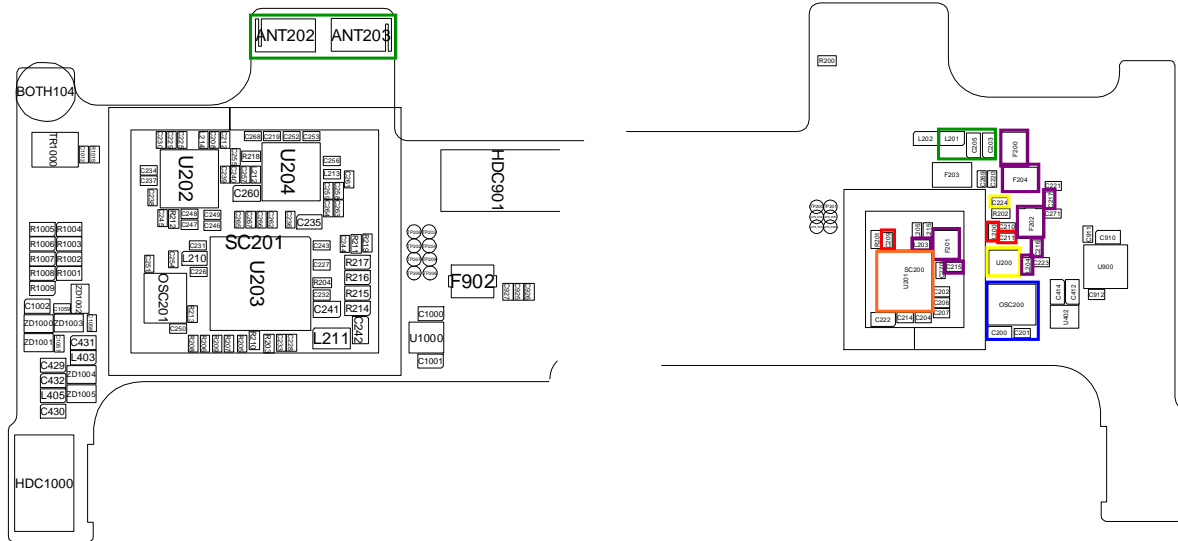

8-3-9. LCD

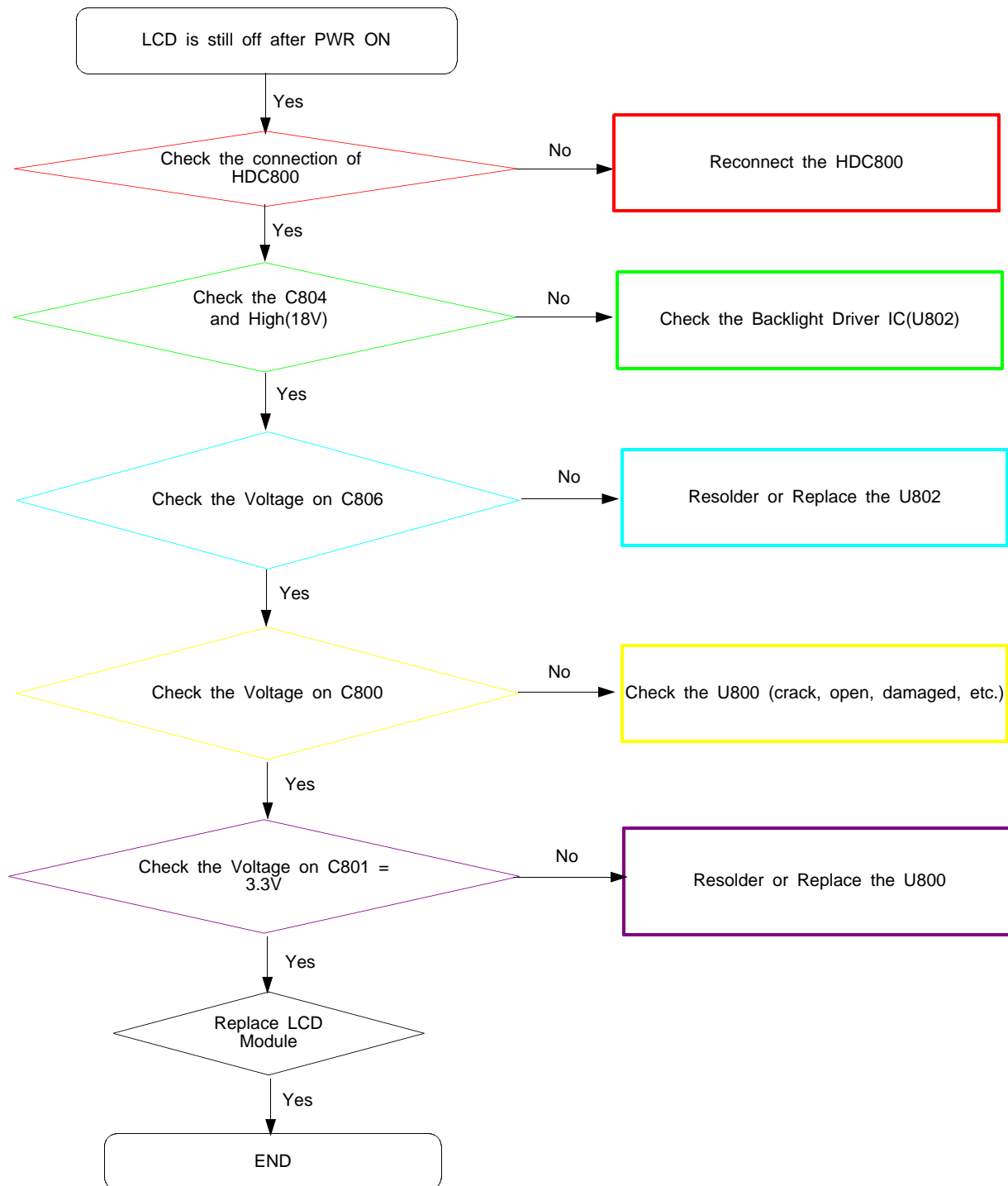

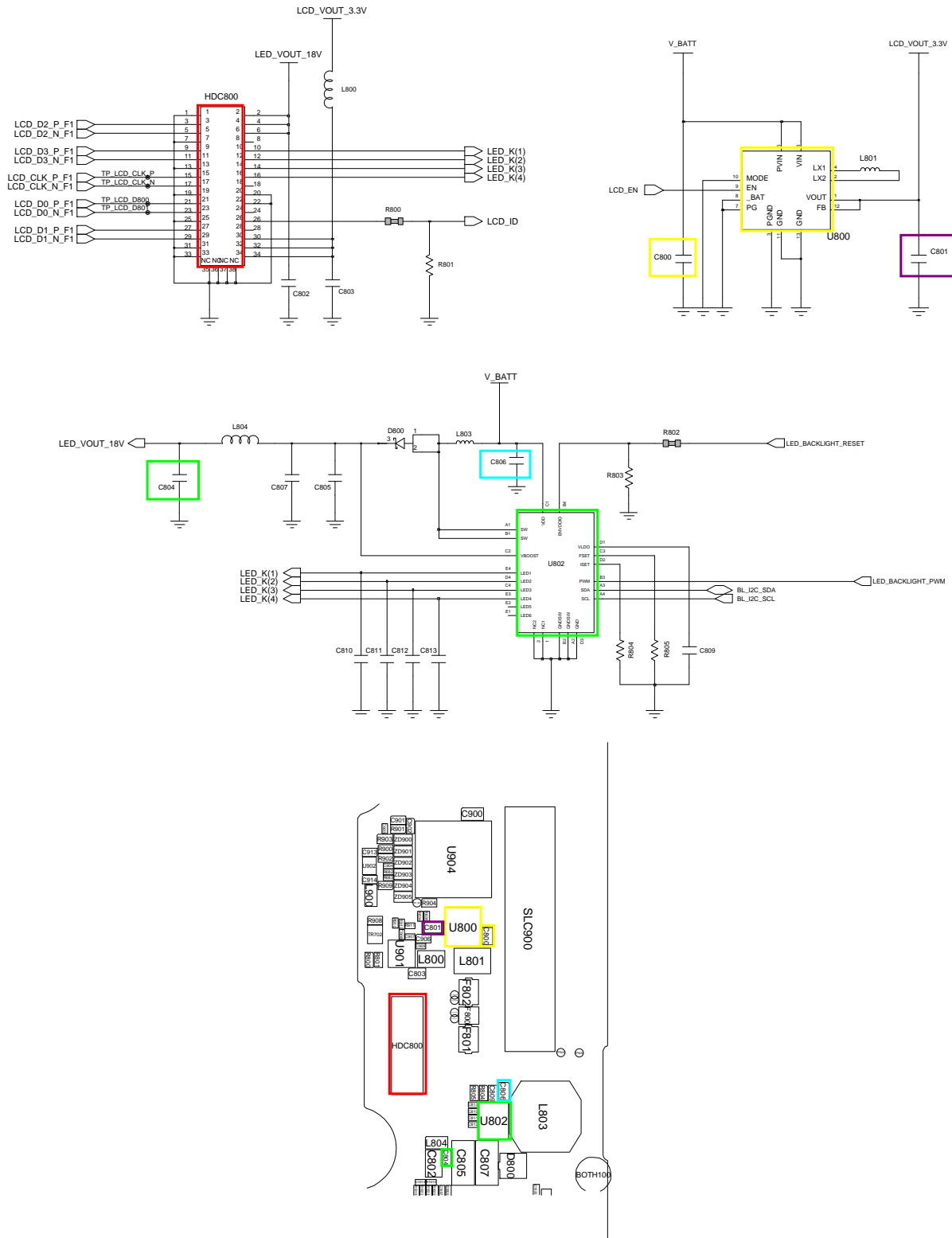

8-3-10. TSP

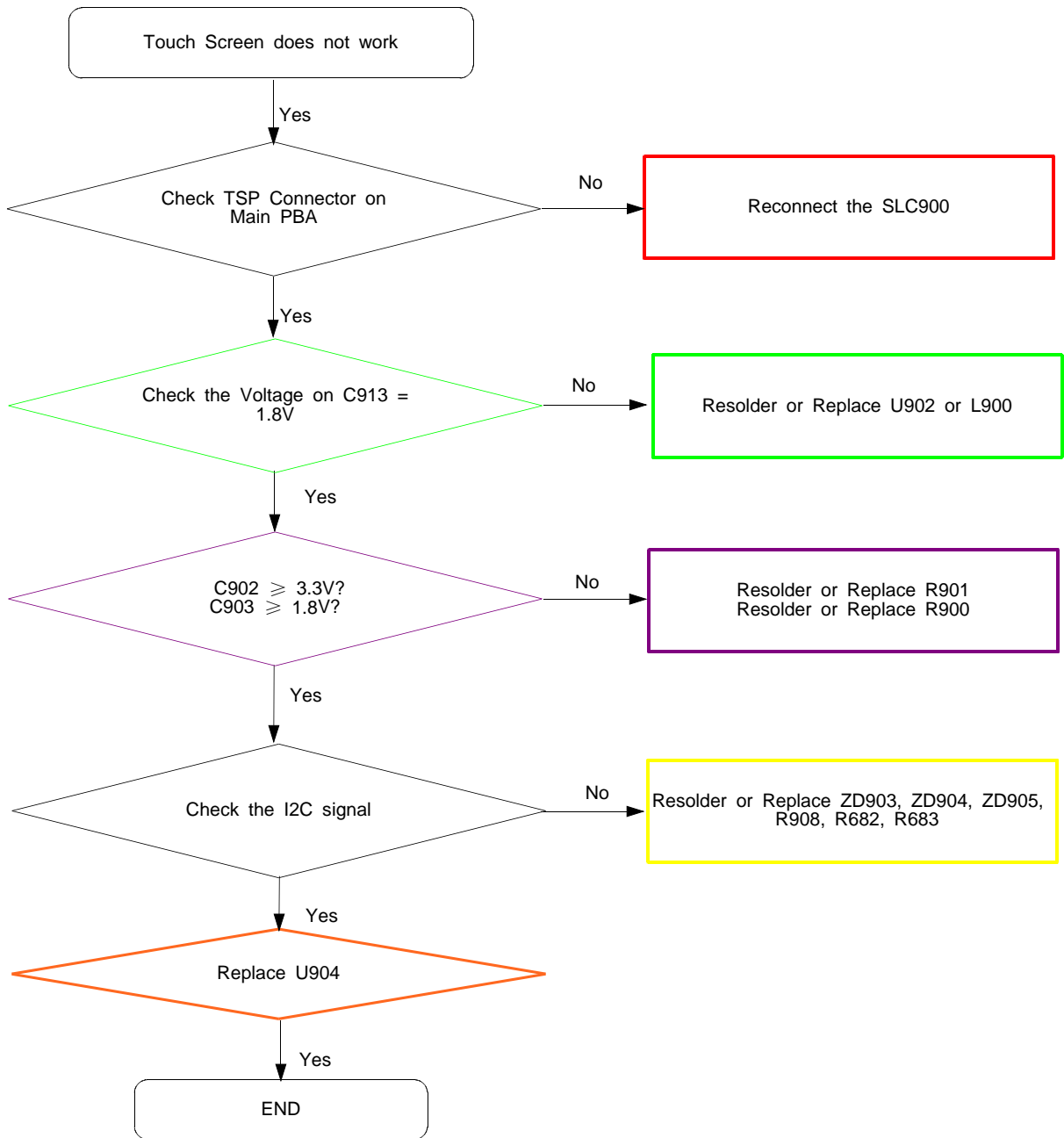

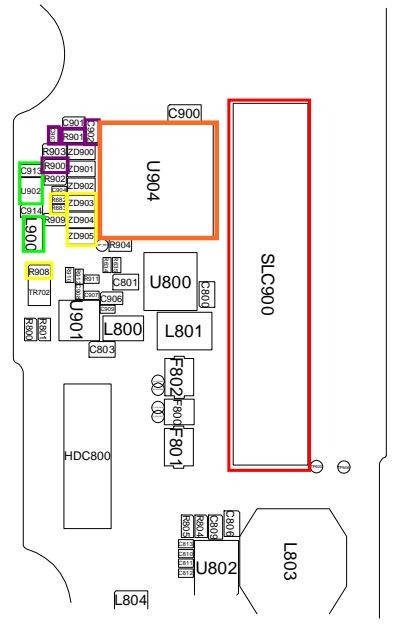
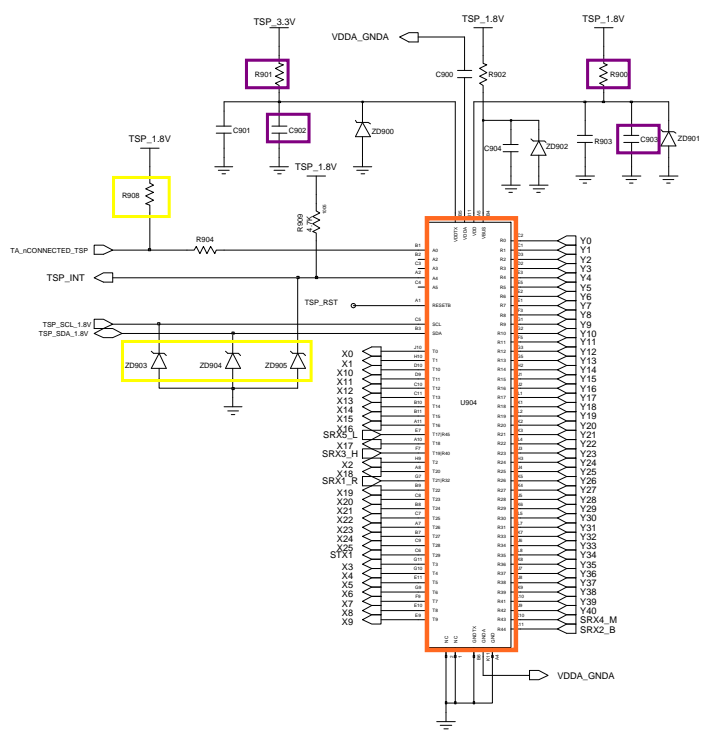
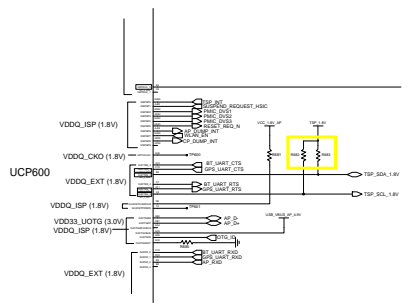
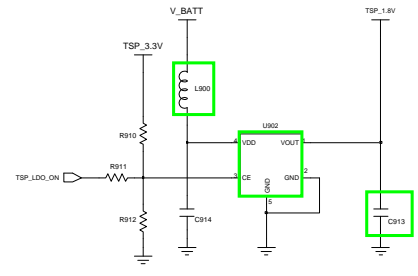
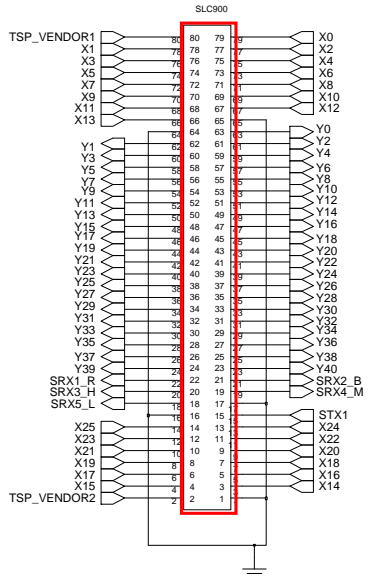

8-3-11. 3M CAM

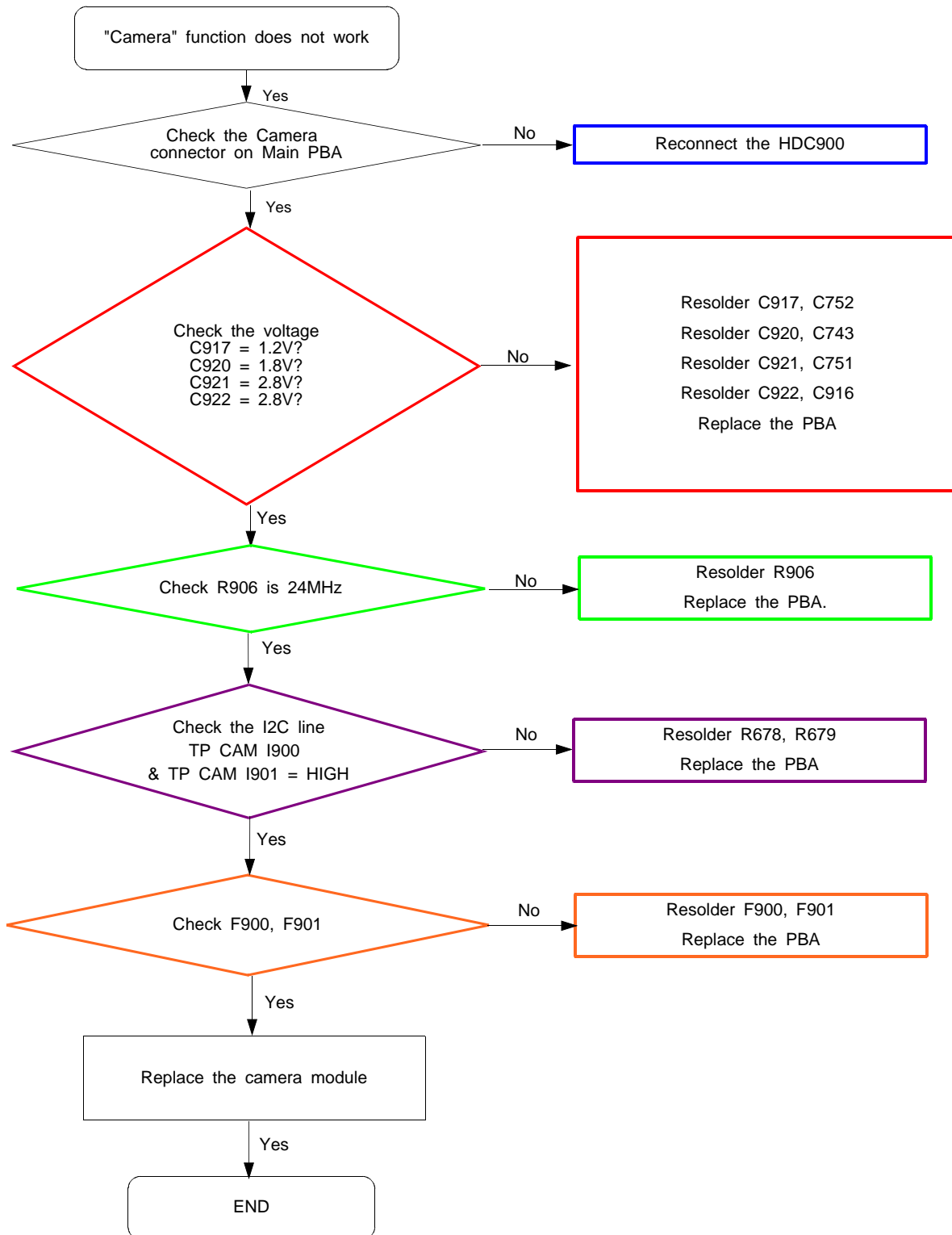

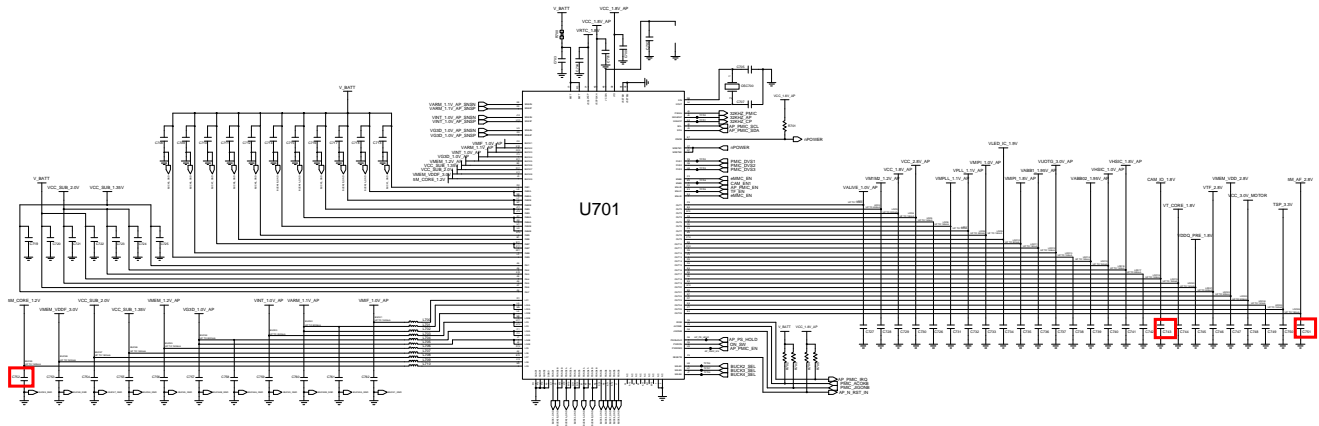
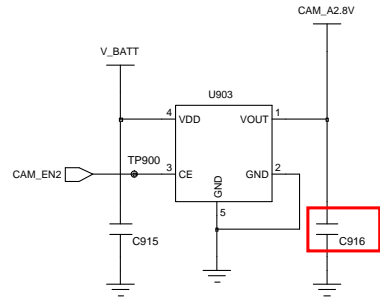
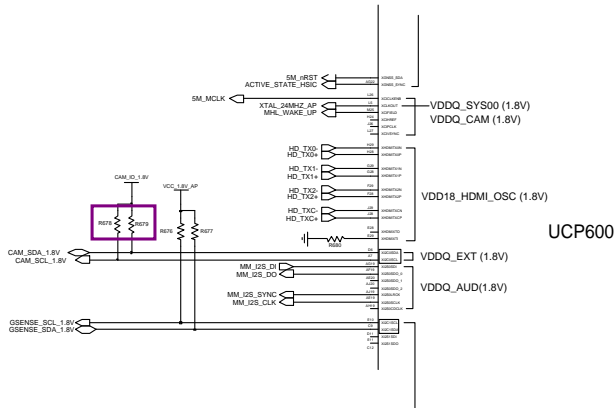
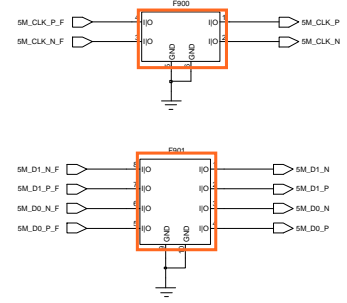
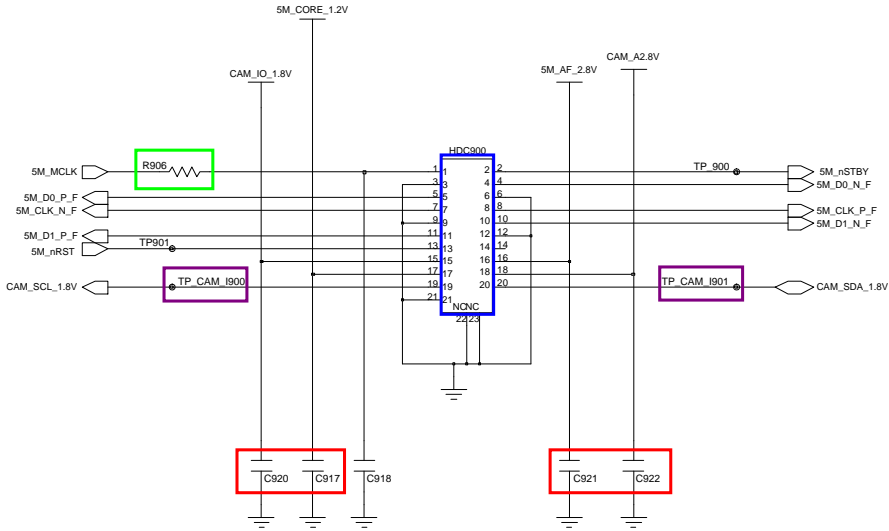

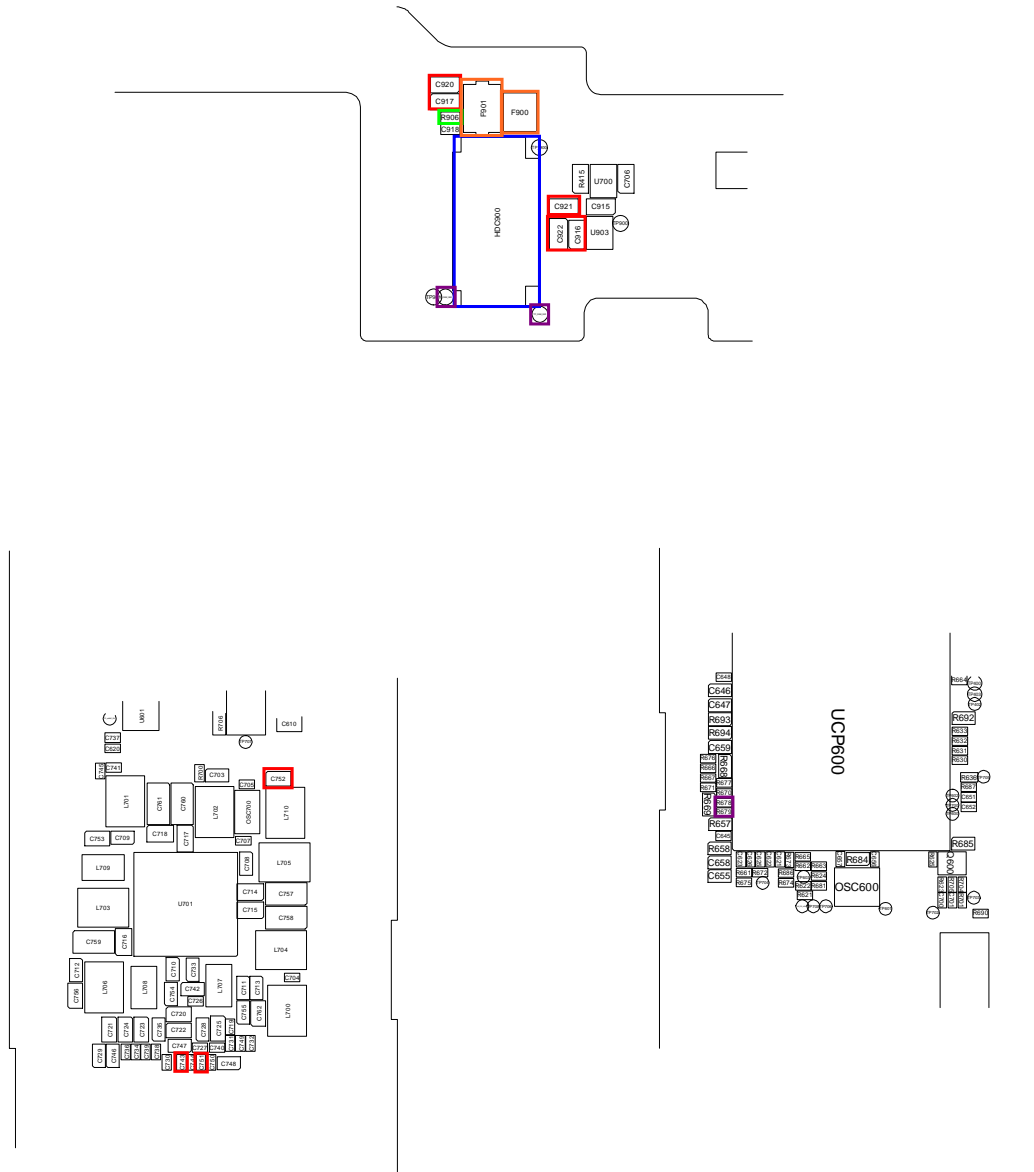

8-3-12. 1.3M CAM

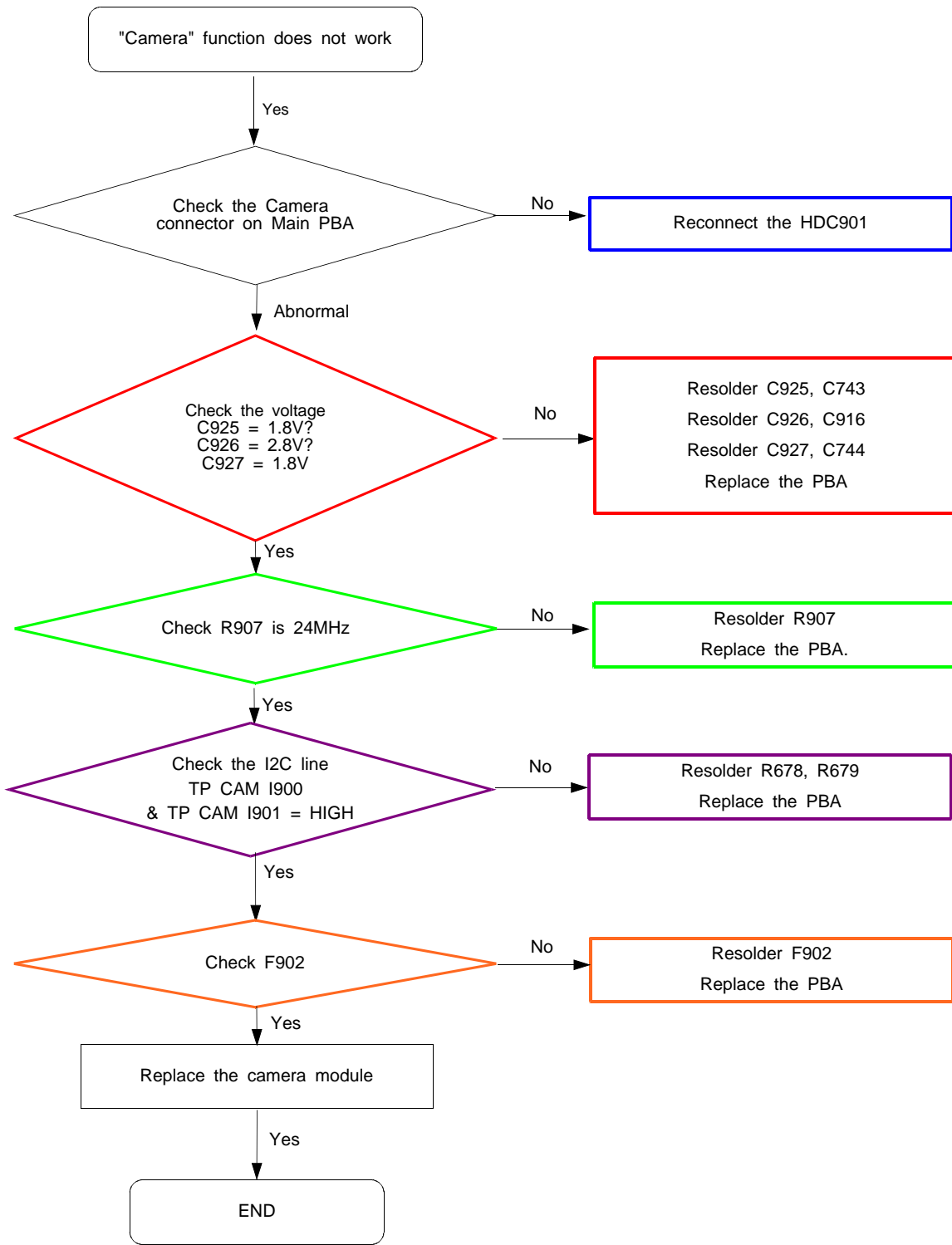

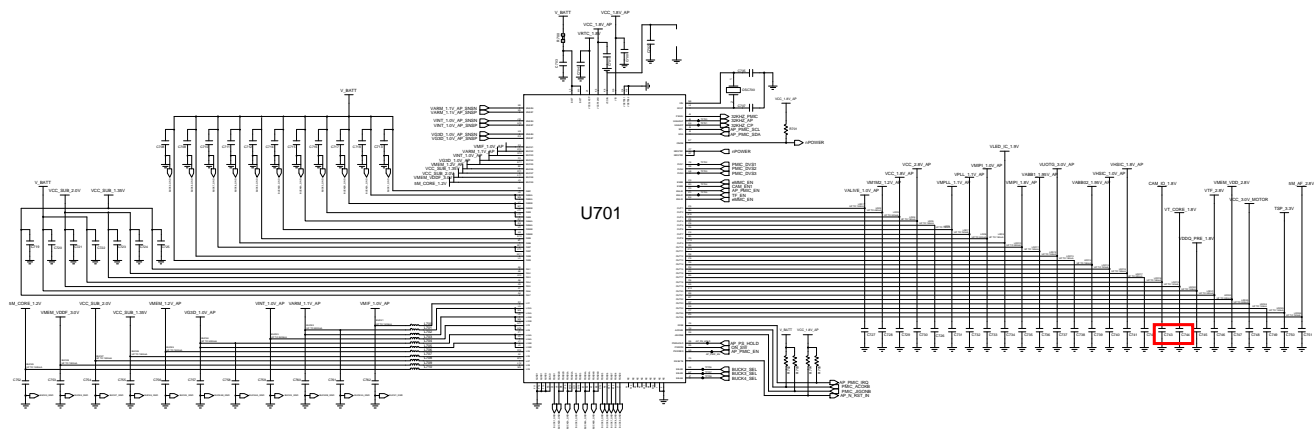
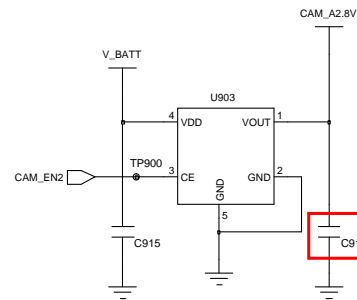
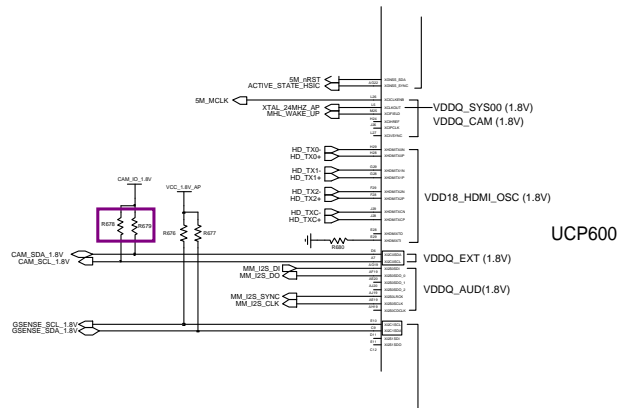
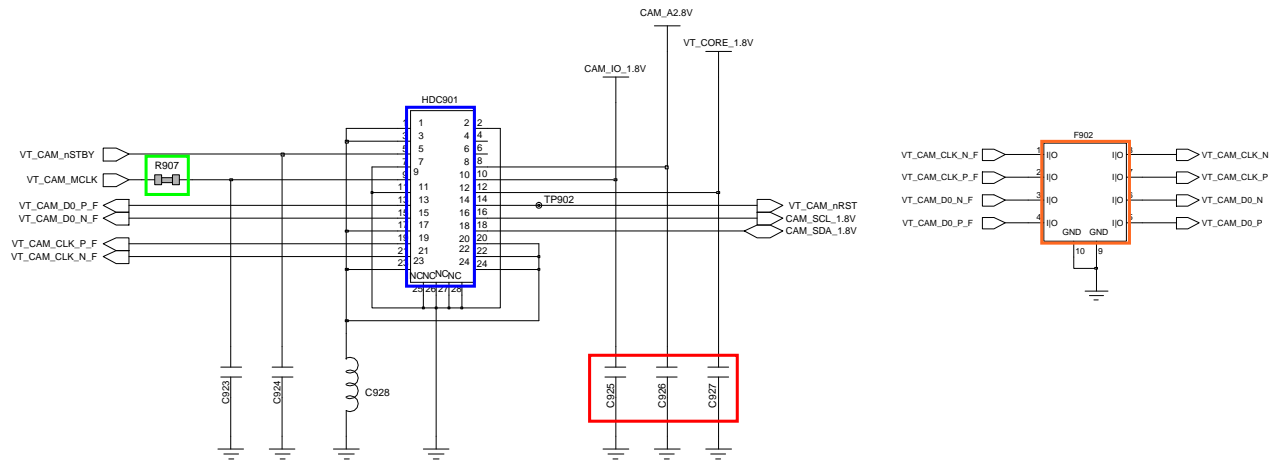

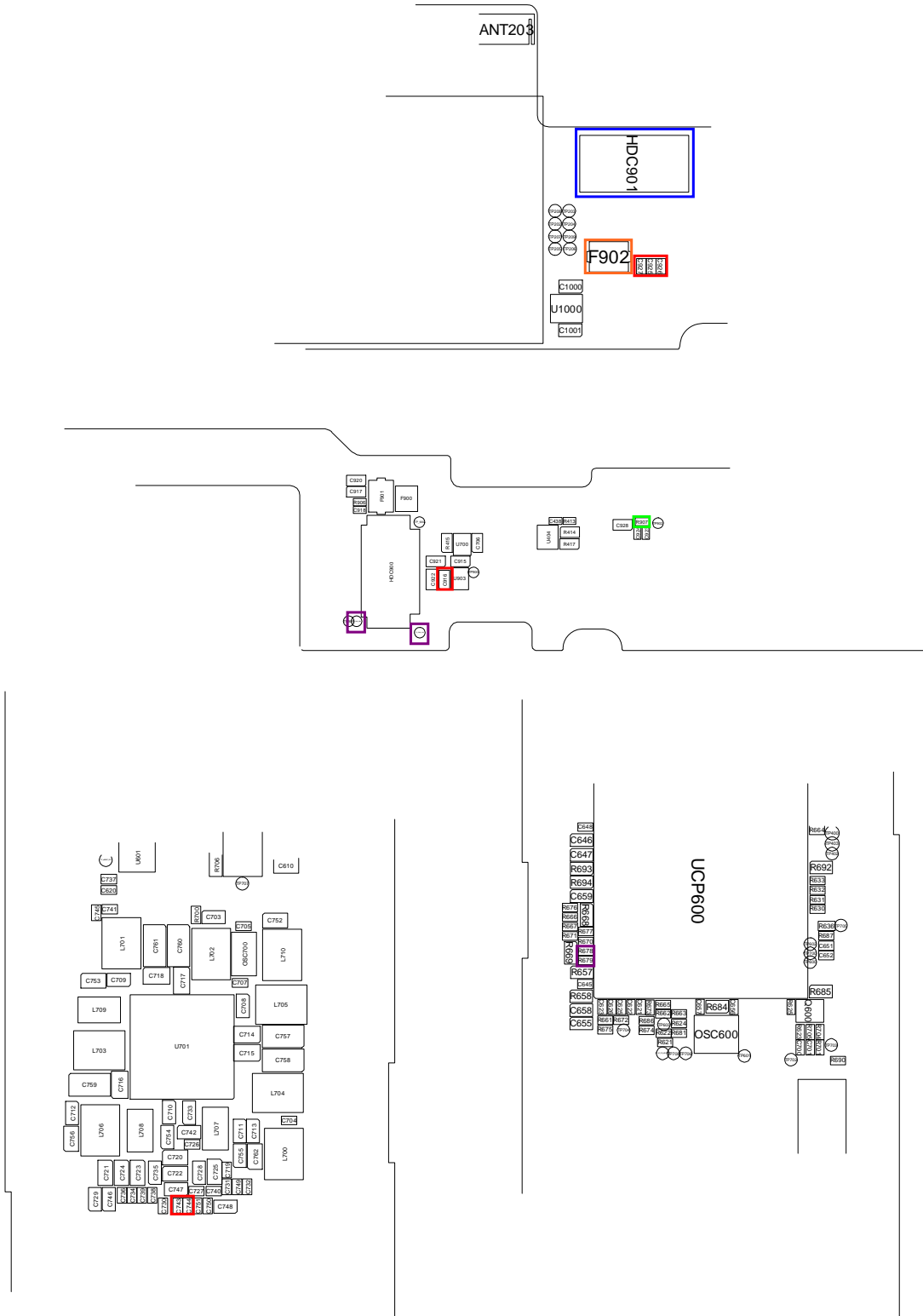

8-3-13. OTG

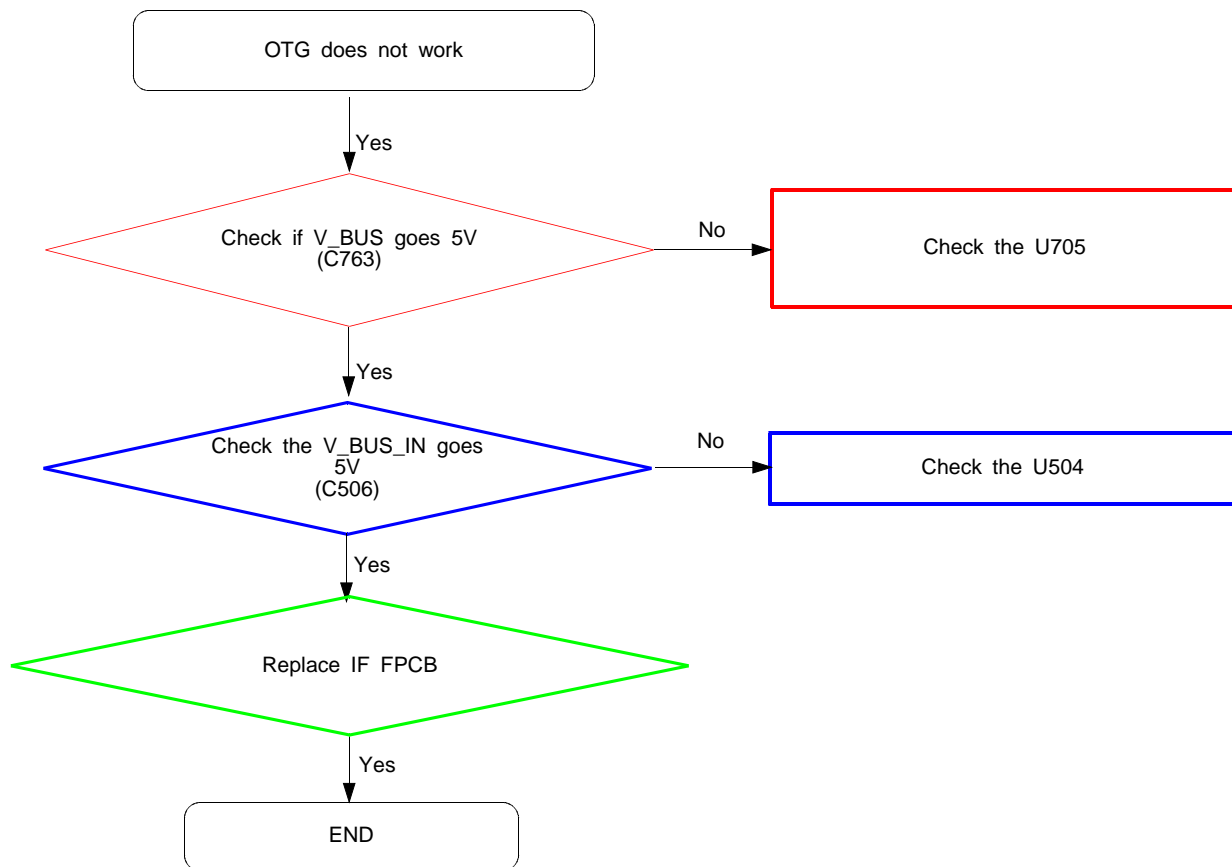

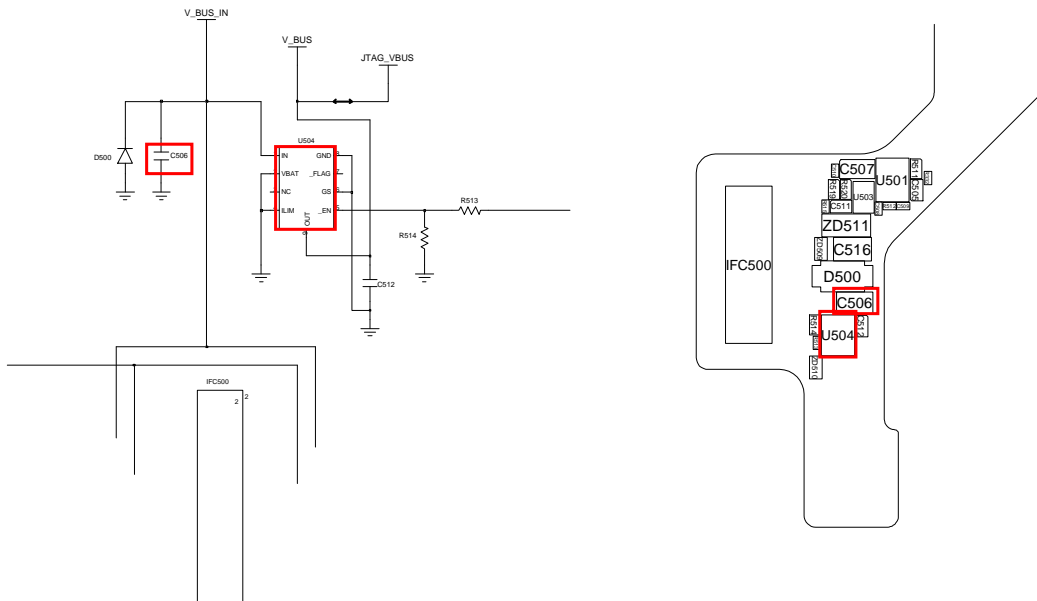
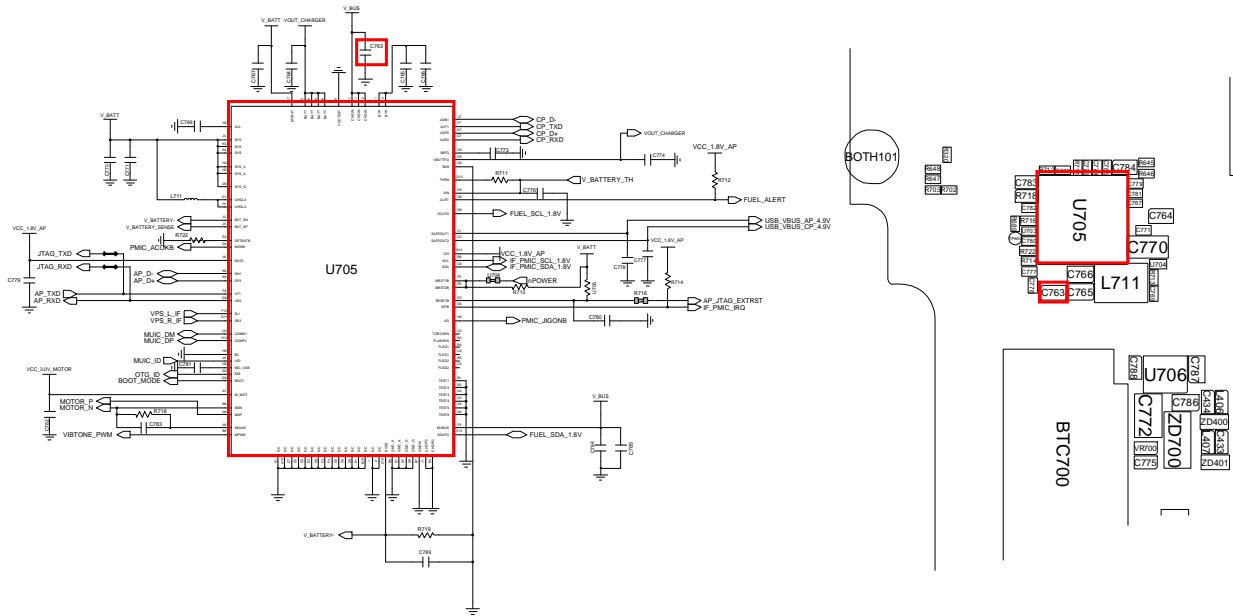

8-3-14. MHL

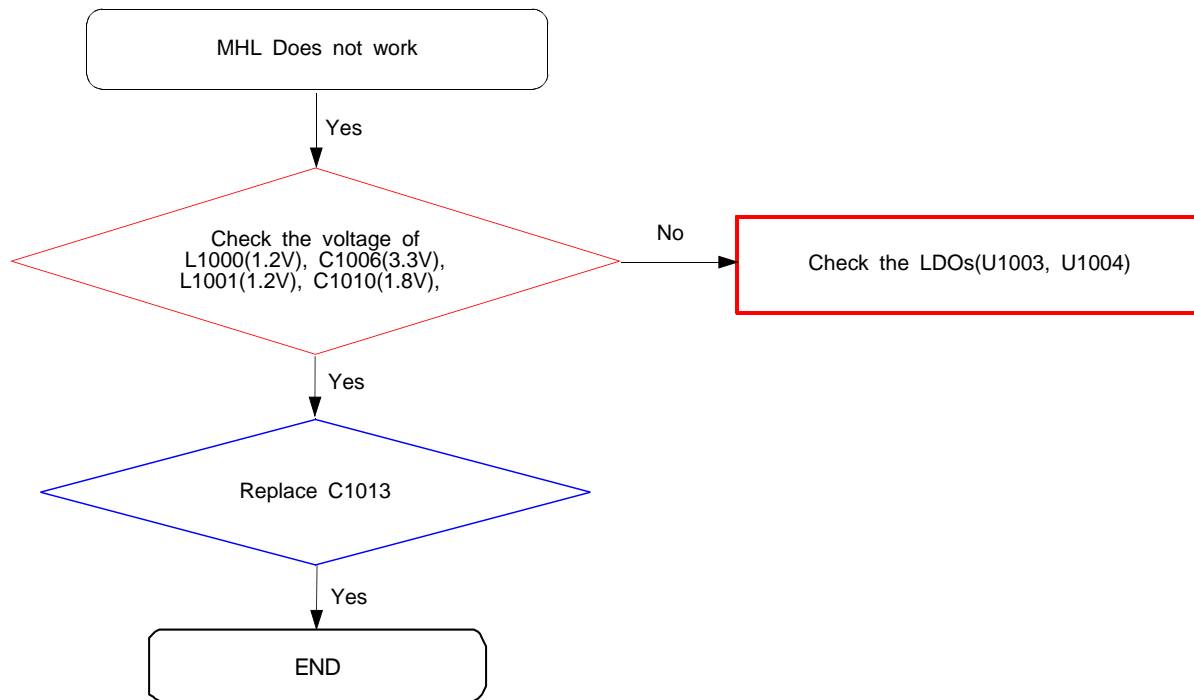

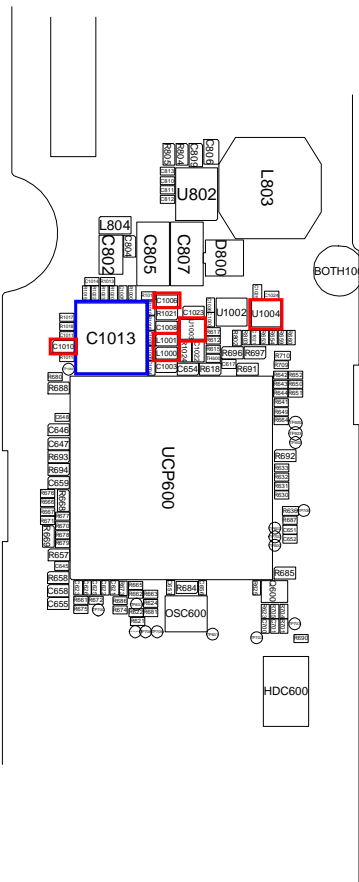
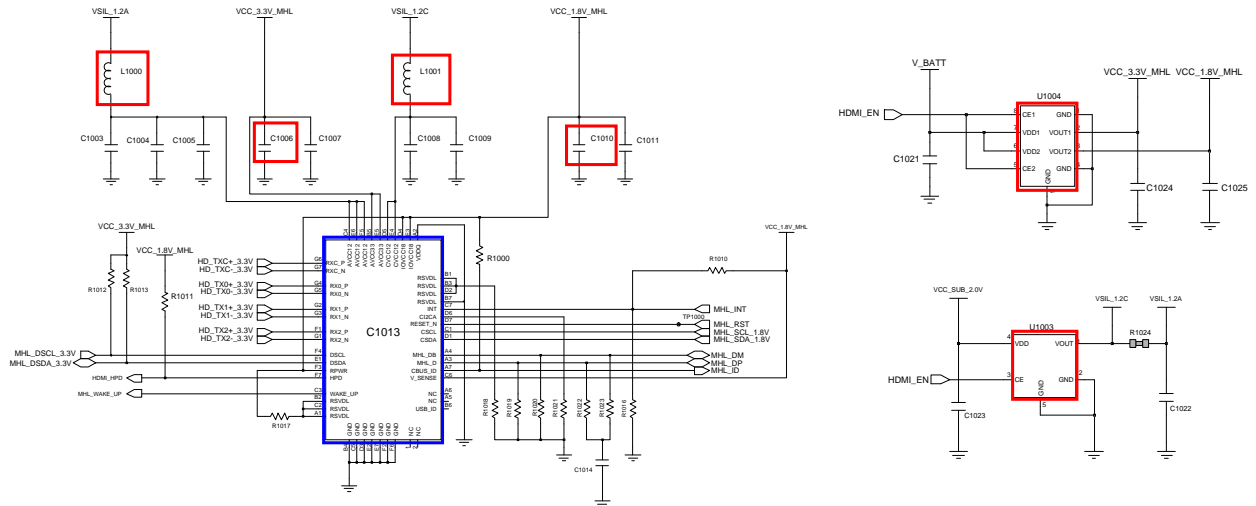

8-3-15. S-pen

